



OSHPC BARKI TOJIK

## **TECHNO-ECONOMIC ASSESSMENT STUDY FOR ROGUN HYDROELECTRIC CONSTRUCTION PROJECT**



## **PHASE II REPORT (FINAL): PROJECT DEFINITION OPTIONS**

**VOLUME 1: SUMMARY**

# TECHNO-ECONOMIC ASSESSMENT STUDY FOR ROGUN HYDROELECTRIC CONSTRUCTION PROJECT

## PHASE II REPORT: PROJECT DEFINITION OPTIONS

### Volume 1: Summary

August 2014

Report No. P.002378 R P58 rev. E

E	07/08/2014	Final Version – August 2014	Various	LCO	LBO
D	13/06/2014	Integration of comments by reviewers	Various	LCO	LBO
C	16/05/2014	Final Stand Alone Version	Various	LCO	NSA
B	16/04/2014	Second Version	Various	LCO	NSA
A	29/07/2013	First Emission	Various	VLI	NSA
<b>Revision</b>	<b>Date</b>	<b>Subject of revision</b>	<b>Drafted</b>	<b>Checked</b>	<b>Approved</b>

## CONTENTS

<b>INTRODUCTION .....</b>	<b>11</b>
<b>VOLUME 2: BASIC DATA .....</b>	<b>13</b>
CHAPTER 2.1: TOPOGRAPHY .....	14
CHAPTER 2.2: GEOLOGY .....	16
1 Introduction.....	16
2 Regional geology .....	18
3 Site geology.....	19
4 Slope stability in the dam site area.....	24
5 Engineering geology .....	27
6 Geological conditions in the Reservoir area .....	31
7 Conclusions and Recommendations.....	33
CHAPTER 2.3: GEOTECHNICS .....	37
1 Introduction.....	37
2 General description of site and investigation performed.....	37
3 Hydrogeology .....	39
4 Dam foundation .....	39
5 Tectonically active faults .....	40
6 Other issues .....	41
7 Conclusions and Recommendations.....	42
CHAPTER 2.4: SEISMICITY .....	44
1 Introduction.....	44
2 Global Tectonic Framework .....	44
3 Geologic Context .....	45
4 Seismicity .....	47
5 Assumptions for DSHA.....	48
6 Seismic hazard Assessment.....	49
7 Reservoir Triggered seismicity (RTS) .....	54
8 Proposed seismic monitoring .....	55
9 Conclusions and Recommendations.....	55
CHAPTER 2.5: METEOROLOGY, HYDROLOGY AND CLIMATE CHANGE .....	57
1 Introduction.....	57
2 Input data.....	57
3 Flood Study .....	58

4	PMF Assessment.....	59
5	Climate change impact .....	61
	<b>CHAPTER 2.6: SEDIMENTATION .....</b>	<b>62</b>
1	Introduction.....	62
2	Vakhsh River Sediment Characteristics .....	63
3	Nurek Reservoir experience.....	63
4	Yearly Solid Run Off Estimate.....	65
5	Review of available sediment management solutions .....	65
6	Conclusions and Recommendations:.....	75
	<b>VOLUME 3: ENGINEERING AND DESIGN.....</b>	<b>77</b>
	<b>CHAPTER 3.1: DESIGN CRITERIA.....</b>	<b>78</b>
1	Introduction.....	78
2	Basic data.....	78
3	Design criteria.....	79
	<b>CHAPTER 3.2: SELECTION OF PROJECT SITE, POWERHOUSE LOCATION, DAM TYPE AND ALTERNATIVES TO BE STUDIED .....</b>	<b>83</b>
1	Introduction.....	83
2	Key features of HPI 2009-2010 project .....	83
3	Selection of the dam site, type and axis.....	85
4	Selection of powerhouse site and type.....	90
5	Selection of the alternatives to study.....	91
6	Conclusions and Recommendations.....	92
	<b>CHAPTER 3.3: ALTERNATIVE DESIGNS .....</b>	<b>93</b>
1	Introduction.....	93
2	Site-Specific features .....	93
3	Dam.....	94
4	River diversion and Management of construction floods .....	104
5	Extreme Flood management.....	111
6	Multi Level Intakes .....	115
7	Power house.....	116
8	Electro-mechanical Equipment .....	117
9	Key data for each alternative .....	118
	<b>CHAPTER 3.3: APPENDIX 1 – CONSTRUCTION MATERIAL ASSESSMENT .....</b>	<b>125</b>
1	Introduction.....	125
2	Dam design – quantities of needed materials .....	125



3	Materials characteristics .....	126
4	Conclusions and Recommendations.....	136
CHAPTER 3.3: APPENDIX 2 – REPORT ON EMBANKMENT DAM STABILITY.....		138
1	Introduction.....	138
2	Review of HPI study.....	138
3	Static analysis performed by the Consultant .....	139
4	Seismic analysis .....	141
5	Stage 1 stability analysis.....	150
6	Conclusion and Recommendations.....	153
CHAPTER 3.3: APPENDIX 3 – FLOOD MANAGEMENT DURING CONSTRUCTION.....		156
1	Introduction.....	156
2	Design criteria.....	156
3	HPI Diversion scheme .....	160
4	Description of proposed diversion structures .....	164
5	Conclusions and Recommendations.....	167
CHAPTER 3.3: APPENDIX 4 – HYDRAULICS OF PROJECT COMPONENTS .....		173
1	Concepts Adopted for the design OF Hydraulic Facilities.....	173
2	Diversion tunnel N° 3.....	179
3	Middle level outlets 1 and 2.....	181
4	Multi-level Intakes .....	186
5	High level tunnel spillways .....	187
6	Surface spillway.....	190
CHAPTER 3.3: APPENDIX 5 – PMF MANAGEMENT .....		196
1	Introduction.....	196
2	Basic Constraints.....	197
3	Analysis of the solution proposed by HPI.....	199
4	Rogun Protection against high floods.....	202
5	Vakhsh protection against High floods .....	204
6	Conclusion and Recommendations.....	206
CHAPTER 3.3: APPENDIX 6 – NOTE ON FREEBOARDS DUE TO WAVES .....		209
1	Introduction.....	209
2	Definitions and hypothesis .....	209
3	Calculation.....	210
CHAPTER 3.4: DRAWINGS .....		212
CHAPTER 3.5: RESERVOIR OPERATION STUDIES .....		216

1	Introduction.....	216
2	Data and Assumptions.....	217
3	Methodology .....	225
4	Scenarios Studied.....	230
5	Simulation Results for Normal Operation .....	232
6	Simulation Results – Filling Period.....	235
7	Conclusions and Recommendations.....	243
	<b>CHAPTER 3.6: TRANSMISSION SYSTEM .....</b>	<b>246</b>
1	Introduction.....	246
2	Reference Documents .....	247
3	System Description.....	247
4	Methods and Softwares used for these studies.....	247
5	Configurations and cases .....	248
6	Network Reinforcements.....	254
7	Conclusions and Recommendations.....	255
	<b>VOLUME 4: IMPLEMENTATION STUDIES.....</b>	<b>258</b>
	<b>CHAPTER 4.1: IMPLEMENTATION SCHEDULE AND CONSTRUCTION METHOD .....</b>	<b>259</b>
1	Introduction.....	259
2	Conclusion and Recommendations.....	260
	<b>CHAPTER 4.2: COST ESTIMATE .....</b>	<b>263</b>
1	Introduction.....	263
2	Methodology .....	264
3	Dam construction assumptions .....	266
4	Disbursement curves .....	274
	<b>VOLUME 5: ECONOMIC AND FINANCIAL ANALYSIS.....</b>	<b>276</b>
	<b>CHAPTER 5.1: ECONOMIC ANALYSIS .....</b>	<b>277</b>
	<b>CHAPTER 5.2: FINANCIAL ANALYSIS .....</b>	<b>298</b>
	<b>VOLUME 6: RISK ANALYSIS.....</b>	<b>303</b>
1	Introduction.....	304
2	Terminology and methodology.....	304
3	Risk identification.....	305
4	Risk evaluation .....	305
5	Conclusions and Recommendations.....	310
	<b>VOLUME 7: CONCLUSIONS AND RECOMMENDATIONS.....</b>	<b>318</b>
1	Design Approach for the Presented Alternatives.....	319

2	Context of the Project Alternatives .....	320
3	Broad Conclusions Of The Alternatives Study.....	324
4	Determination of Preferred Project Configuration.....	330
5	Conclusion and Recommendation .....	333
6	Details of the Recommended Alternative .....	335

<b>APPENDIX A: SUMMARY OF MAIN RECOMMENDATIONS OF INVESTIGATIONS, TESTS AND STUDIES TO BE PERFORMED EARLY IN THE NEXT STAGES OF THE PROJECT .....</b>	<b>342</b>
---	------------

## FIGURES

Figure 1: Topographical data .....	15
Figure 2: Main faults near the project area.....	19
Figure 3: Schematic Cross Section Showing Thrust Rates for Main Faults (modified from [3])....	21
Figure 4: Right Bank Interpretive Cross Section, view from the SW. ....	26
Figure 5: India-Asia collision and induced deformation within Eurasia. Rogun HPP is located within the western syntax of the Himalaya, characterized by intensive shortening. ....	45
Figure 6: Two interpretations of subsurface geological structure in the PFR .....	46
Figure 7: Synthetic assumption for Maximum Historical Earthquake .....	48
Figure 8: Comparison between the proposed response spectra for 5% damping associated to both the Guissar and Vakhsh faults. ....	52
Figure 9 : 10 000 yrs and PMF Flood Hydrographs.....	60
Figure 10 : Evolution of optimum minimum reservoir level, firm energy and sediment level with time, for a sediment load of 100 Mm <sup>3</sup> /yr .....	70
Figure 11 : Proposed surface spillway longitudinal profile .....	73
Figure 12: Dam Cross Section. Alternative FSL=1,290 m.a.s.l. ....	99
Figure 13: Longitudinal section of the stepped spillway.....	115
Figure 14: Core Grading Curve .....	131
Figure 15: Specifications for Fine and Coarse Filter Grading Curve .....	132
Figure 16: Coarse Filter and Shoulder Grading Curves.....	133
Figure 17: Rockfill and Shoulder Grading Curves.....	134
Figure 18: Riprap grading curves.....	136
Figure 19 : Calculation cross section ( Dam stability 3D modelling, Hydroproject, 2009).....	139
Figure 20 : Layout of the cross-sections.....	140
Figure 21 : Cross sections for dynamic analysis - Plan view .....	143
Figure 22 : MCE spectral acceleration distribution (damping ratio 5%).....	144
Figure 23 : Section 2-1, Relative displacement at several elevations .....	148
Figure 24 : Stage 1 dam geometry .....	151
Figure 25 : Plan view - Diversion and spillway structures – HPI scheme.....	161
Figure 26 : Operation range of discharge tunnel - HPI .....	162
Figure 27 : HPI Diversion scheme.....	163
Figure 28 : Plan view - Diversion structures proposed: .....	165
Figure 29 : Location of downstream cofferdams.....	166
Figure 30 : FSL = 1290 masl - Diversion structures operating range.....	170
Figure 31 : FSL = 1290 masl - Diversion scheme along time .....	170
Figure 32 : FSL = 1255 masl - Diversion structures operating range.....	171
Figure 33: FSL = 1255 masl - Diversion scheme along time .....	171
Figure 34 : FSL = 1220 masl - Diversion scheme along time .....	172
Figure 35 : 3rd operation spillway - longitudinal section .....	200
Figure 36 : Remote spillway and Operation shaft spillway - longitudinal section .....	200
Figure 37 : Extract of HPI studies - spillways discharge capacity versus reservoir elevation .....	201
Figure 38 : Vakhsh cascade scheme .....	218
Figure 39 : Rogun and Nurek reservoir capacity vs elevation.....	220
Figure 40 : Rogun reservoir storage capacity FSL =1290 masl- Impact of sedimentation .....	221
Figure 41 : Rogun reservoir storage capacity FSL =1255 masl- Impact of sedimentation .....	221
Figure 42 : Rogun reservoir storage capacity FSL =1220 masl- Impact of sedimentation .....	222
Figure 43 : Nurek reservoir storage capacity.- Impact of sedimentation without Rogun.....	222
Figure 44 : Dam rise schedule - FSL=1290, 1255 and 1220 masl.....	224
Figure 45 : Historical Nurek outflow and reservoir level (1991-2008).....	227
Figure 46: Historical Nurek energy production (1991-2008) .....	227
Figure 47 : Nurek Outflows duration curve (historical and simulated).....	228
Figure 48 : Vakhsh cascade production - Comparison of the alternatives, Scenario (b) .....	234
Figure 49: Vakhsh cascade production - Comparison of the alternatives, Scenario (a) .....	235

Figure 50 : Rogun reservoir filling - Simulation results FSL=1290 masl.....	236
Figure 51 : Discharge at the downstream end of the Vakhsh - Filling FSL=1290 masl .....	238
Figure 52 : Rogun reservoir filling - Simulation results FSL=1255 masl.....	238
Figure 53 : Discharge at the downstream end of the Vakhsh - Filling FSL=1255 masl .....	240
Figure 54 : Rogun reservoir filling - Simulation results FSL=1220 masl.....	241
Figure 55 : Discharge at the downstream end of the Vakhsh - Filling FSL=1220 masl .....	242
Figure 56: Cost Estimate – Phase II, diagram .....	264
Figure 57: Typical Longitudinal Cross Section of Dam .....	268
Figure 58: Dam Phasing - Longitudinal Cross Section .....	269
Figure 59: Belt Conveyor System.....	272
Figure 60: Dam fills – Unit cost methodology. ....	273
Figure 62 : Disbursement curve – Permanent Equipment .....	275
Figure 63 : Disbursement curve - Administration and Engineering .....	275
Figure 65: Tajikistan capacity mix by technology type – Rogun 1290 masl, 3,200 MW .....	289
Figure 66: Tajikistan quarterly net exports – Rogun 1290 masl, 3,200 MW .....	290
Figure 67: Project cost breakdown over the Forecast Horizon .....	299
Figure 68: Level of Risk Before and After Mitigation Measures for risks having an original level of risk equal or higher than moderate.....	307

## TABLES

Table 1: Maximum Historical Earthquake (MHE).....	48
Table 2: Estimate of the Maximum Credible Earthquake (MCE).....	49
Table 3: PGA and Response Spectra, Bommer et al., 2010.....	50
Table 4: Horizontal Geometric-mean PGAs, MCE=MHE+0.5 /median PGA + 0.5 standard deviation .....	50
Table 5: Horizontal Geometric-mean PGAs, MCE=MHE / median PGA + 1 standard deviation ..	50
Table 6: Estimates of co-seismic displacements associated with the MCE on the Ionakhsh ramp.	53
Table 7: Gauging stations .....	58
Table 8 : Synthesis of Flood Frequency Analysis .....	59
Table 9 : Evolution of Nurek reservoir capacity .....	63
Table 10 : Power intake life span with raising intake .....	71
Table 11 : Estimated Rogun reservoir ultimate life span.....	72
Table 12 : Possibility of Stages in the Construction of the Dam.....	88
Table 13: Comparison of Dam Types – Synthesis.....	89
Table 14: Full supply level alternatives to study and corresponding rationale.....	91
Table 15: Installed capacities selected.....	91
Table 16: Dam - Key data of HPI design 2009 .....	95
Table 17: Materials quantities. HPI, Design 2010.....	96
Table 18: Foundation treatment, HPI .....	96
Table 19: Processing/Treatment Specification .....	98
Table 20: Construction Phases .....	100
Table 21: Material Quantities in-situ [m <sup>3</sup> ].....	101
Table 22: Assessment of Materials .....	102
Table 23: Rock excavation volume .....	102
Table 24: Construction Flood - Probability of Occurrence and Return Period.....	104
Table 25: River Diversion Assessment.....	105
Table 26: Diversion structure for each dam alternative and each construction phase .....	106
Table 27 : Peak and daily maximum discharge .....	111
Table 28 : Number of tunnels available at the end of construction .....	112
Table 29 : Surface spillway characteristics.....	112
Table 30 : Alternatives to be studied .....	117
Table 31: Main Required Quantities for Dam Construction.....	126
Table 32: Estimation of Losses and Expansion/Compaction Coefficients.....	128
Table 33: Main Characteristics of Materials for Dam Construction .....	128
Table 34: Segregation criterion, (ICOLD 1994) .....	129
Table 35 : Static analysis – Results .....	141
Table 36: Design earthquake PGA.....	144
Table 37: Principal natural frequencies of section 2-1 .....	145
Table 38 : Principal natural frequencies of section 2-2 .....	145
Table 39 : Principal natural frequencies of section 2-3 .....	146
Table 40 : Equivalent linear results - Dam fundamental frequency .....	147
Table 41 : Results of Seismic analysis – Settlement .....	149
Table 42 : Results of Seismic analysis – Horizontal permanent displacement.....	149
Table 43 : Design criteria for the Stage 1 dam .....	151
Table 44 : Stage 1 dam stability analysis – Results.....	152
Table 45: Stage 1 dam crest settlement during earthquake - Swaisgood formula .....	153
Table 46 : Design Floods. Ranges to be explored (FSL=1290 masl).....	157
Table 47: Design Floods. Ranges to be explored (FSL=1255 masl).....	157
Table 48 : Design Floods. Ranges to be explored (FSL=1220 masl).....	158
Table 49: Main Characteristics of HPI Diversion Tunnels.....	160



Table 50 : high level spillways available at the end of construction .....	202
Table 51: Surface spillway main features .....	203
Table 52: Calculated Run-up .....	210
Table 53: Calculated wind tide Results .....	211
Table 54 : Storage and regulation capacity of Vakhsh HPP's .....	217
Table 55: Average of actual water withdrawals and return flow during 2005-2011 (m3/s) .....	219
Table 56 : Projected water withdrawals and return flow (m3/s).....	219
Table 57 : Vakhsh cascade installed capacity and maximum discharge.....	223
Table 58 : Installed capacities selected.....	223
Table 59 : Key dates for early generation.....	225
Table 60 : Calibration Period and Model Simulation Period.....	226
Table 61 : Scenario and alternatives simulated.....	232
Table 62 : Vakhsh cascade firm energy of all simulated scenario .....	232
Table 63 : Vakhsh cascade secondary energy of all simulated scenario .....	233
Table 64 : Vakhsh cascade average energy of all simulated scenario.....	233
Table 65 : Rogun filling - Energy production - FSL=1290 masl.....	237
Table 66 : Rogun filling - Energy production - FSL=1255 masl.....	239
Table 67 : Rogun filling - Energy production - FSL=1220 masl.....	242
Table 68: Scheduled New 500 Kv Connections .....	250
Table 69: Tajik Power Plants .....	252
Table 70 : Quantities Available in Stockpiles, [Mm3] .....	267
Table 71 : Materials Quantities for each Alternative, [Mm3] .....	269
Table 72:: Alternative 1290 - Sources .....	270
Table 73: Alternative 1290 – Quantities [m3].....	270
Table 74: Alternative 1255 - Sources .....	270
Table 75: Alternative 1255 – Quantities [m3].....	271
Table 76: Alternative 1220 - Sources .....	271
Table 77: Alternative 1220 – Quantities [m3].....	271
Table 78: PV of TSC savings by sensitivity @ 10%.....	286
Table 79: NPV @ 10% of different Rogun design options across sensitivities.....	287
Table 80: Sensitivity of PV of TSC savings for Rogun 1290 masl, 3,200 MW @ 10% discount rate .....	291
Table 81: Sensitivity of economic NPV for Rogun 1290 masl, 3,200 MW @ 10% discount rate	292
Table 82: Sources of funding assumptions.....	300
Table 83: Total returns by financing structure .....	301
Table 84: Risk Estimation Table [MUS\$].....	306
Table 85: Risk Distribution by Severity Level .....	306
Table 86 : Risk sheet summary.....	310
Table 87 : Dam alternatives main features .....	324
Table 88 : EM Equipment - Final Dam Elevation 1290 m.a.s.l.....	325
Table 89 : EM Equipment - Final Dam Elevation 1255 m.a.s.l.....	325
Table 90 : EM Equipment - Final Dam Elevation 1220 m.a.s.l.....	325
Table 91 : Implementation Schedule - Key data 1 - Time from Pre-Contract (in months) .....	325
Table 92 : Energy production during construction for all dam alternatives .....	326
Table 93 : Implementation Schedule - Key data 2 – Time from Pre-Contract (in months).....	327
Table 94 : Average Yearly Energy - Dam Alternative FSL 1290 m.a.s.l.....	328
Table 95 : Average Yearly Energy - Dam Alternative FSL 1255 m.a.s.l.....	328
Table 96 : Average Yearly Energy - Dam Alternative FSL 1220 m.a.s.l.....	328
Table 97 : Estimated Rogun reservoir ultimate lifespan.....	329

## INTRODUCTION

This present document is a summary of the outcome of design activities carried out by the consultant under Phase II of the Techno-Economic Assessment studies for Rogun Project. The Techno-Economic Assessment Studies (TEAS) have been developed by the Consultant for the Government of Tajikistan with funding from the World Bank. The TEAS-Consultant is constituted by Coyne et Bellier of France, Electroconsult of Italy and IPA of the United Kingdom, jointly working for the Rogun Hydropower Project.

Separately, but in parallel, an Environmental and Social Assessment (ESIA) has been developed by another consultant. The ESIA is reported independently of the techno-economic assessment studies.

In the Phase 0 of the studies, the TEAS Consultant made an assessment of the measures required to mitigate the potential impact of the salt wedge that exists at the Rogun site. The Summary of the Phase 0 report has been previously disclosed publicly.

In the Phase I of the studies, the TEAS Consultant made an assessment of all previous work done to date on the Rogun HPP. The Phase I report has been previously disclosed publicly.

In the Phase II of the studies, the TEAS Consultant has assessed the existing design of the Rogun HPP (a 335 m high embankment dam and an installed capacity of 3,600 MW) and evaluated different options for dam type, dam height, construction phasing, reservoir operations as well as issues of dam and overall safety.

The Phase II report is composed of seven volumes, for which the main assumptions, conclusions and recommendations have been reproduced in the present volume.

Volume 1 is the present document, acting as a stand alone summary of the whole report.

Volume 2 describes the basic data collected by the consultant together with the analysis used to derive the different alternatives (Topography, Geology, Geotechnics, Seismicity, Meteorology, Hydrology and Sedimentation).

Volume 3 refers to the design approach used by the Consultant to derive the alternatives to be studied, including a clear set of design criteria, a discussion on the selection of site and type of structures suitable to the context and calculation reports for the main components of the project.

Volume 4 describes the construction methodology and sequence proposed to be adopted for each alternative together with a detailed cost estimate of all proposed options.

Volume 5 addresses the economic and financial aspects of the different alternatives.

Volume 6 is a complete risk analysis of the project together with proposed mitigation measures and recommended actions.

Finally Volume 7 is the conclusion of the Techno-Economic Assessment together with the justification of the choice for the recommended option to be taken forward for detailed consideration.

## VOLUME 2: BASIC DATA

## CHAPTER 2.1: TOPOGRAPHY

For the TEAS studies, the Consultant used the information provided during the course of the studies complemented by additional data collected on site:

- Data provided by Barki Tojik
  - Scanning survey from 2km upstream to dam axis (500 m wide band, 10mx10m grid);
  - Digital topography of the dam site (contour lines every 20 m at maximum elevation, and every 1 m close to river bank);
  - Aerial photography (7.1x9.1 km photo);
  - 1/10 000 map extended from the dam axis to 10km downstream;
- Digital Elevation Model from Aster data (30mx30 m grid)
- GPS tracks of the road network

In particular, for the construction studies, the Consultant used:

- the ASTER data to create elevation contour lines every 50 m of the whole construction site,
- the aerial photograph to locate roads and various infrastructures,
- GPS road survey to know the precise roads profiles.

The different types of data available for the Rogun site are displayed on the figure below:

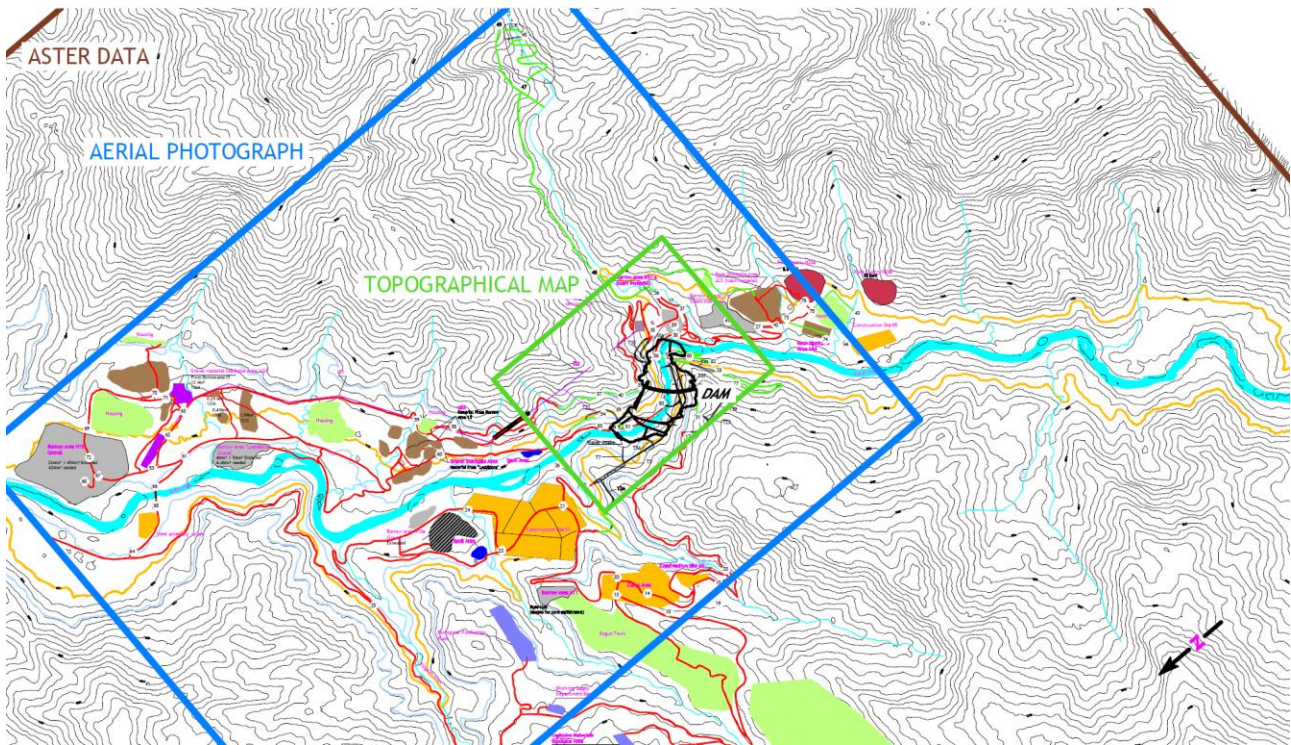

Figure 1: Topographical data



## CHAPTER 2.2: GEOLOGY

### 1 INTRODUCTION

#### 1.1 List of References

- [1] Rogunskaya Hydropower Station on the Vakhsh River, Technical Project. Hidroproyekt Tashkent, 1978.
- [2] Engineering-Geologic Conditions of Constructing The Rogun Dam, A.V.Kolichko and V.N.Fil, 1981.
- [3] Feasibility Study for Phase I of the Stage 1 Construction of Rogunskaya Hydropower Station Dam. HPI Moscow, 2000.
- [4] Instrumental Monitoring of the Newest Tectonic in the Region of Rogunskaya HPS Construction. Lenmetrogioprotrans ("LMGT"OJSC), Saint-Petersburg 2005
- [5] Specification of Prestack Seismicity of the Area of Rogunskaya HPS and Definition of Design Earthquake Effect Parameters. LLC "Center of Geodynamical Researches" "CGR". Moscow (for Hidrospetsproyekt), 2005
- [6] Specification of Initial Seismicity of Rogun HPP Area and Characterization of the Designed Seismic Load. HPI Moscow, 2005
- [7] Geophysical and Geological Engineering Survey for Diagnostic Study of the Existing Constructions Of The Underground Part Of Rogunskaya HPP Geodynamic Research Center (CGI), Moscow, 2005
- [8] Instrumental Monitoring Of The Newest Tectonics In The Region Of Rogunskaya HPS Construction, A.V.Kolichko, 2005.
- [9] Contemporary Status Of Rogun HEP Underground Turbine House, Kolichko A.V., 2006
- [10] Rogun Hydroelectric Plant in the Republic of Tajikistan, Bankable Feasibility for Stage 1 Construction Completion. Geology, Geotechnics and Seismic Characteristics. LI, 2006.
- [11] Comparative Analysis of Rockslide Hazard in the Area of the Rogun Reservoir for FSL 1240 and 1290m Options, CSGNO, Moscow, 2006
- [12] Report on Compilation and Analysis of the Results of Engineering Geology, Ground Water Infiltration, Geomechanical, Geophysical and Other Types of Research in the Area of the Main Structures for the Development of the Rogun Project. HPI, 2009.
- [13] Rogun HPP, Conception of Project Completion, HPI, 2009. In particular 'Concept of Extension of the 1st Stage Plant, Explanatory Note' and 'Geotechnical Conditions'.
- [14] TEAS for Rogun HPP, Inception Report, 2011
- [15] TEAS for Rogun HPP, Geological Investigations in the right bank, 2012

## 1.2 Former Investigations

Field investigations and surveys for the proposed project began in 1967. The vast majority of geological and geotechnical investigations were carried out under the Technical Project, issued in 1978. The results of this comprehensive work became key references for all later studies. Additional geological and geotechnical data were obtained subsequently, during construction work carried out between 1976 and 1993. Over this long period of time, the most valuable data were obtained by direct monitoring of the convergence and behavior of rock mass, as well as the support in the underground works, which comprises half of the Powerhouse cavern, the Transformers cavern, and about 27 km of tunnels excavated for various purposes.

Other studies were later carried out after the 1993 flood and subsequent stoppage of construction. Recent studies for updating the design according to modern international standards have been carried out since the year 2000, for which the most relevant references mentioned above are [4], [7], [12] and [13].

## 1.3 Additional Investigations – 2012

Taking into account the significant amount of geological and geotechnical data provided by previous investigations, only limited additional investigation was required to be carried out during the course of the TEAS. The main objectives of this additional investigation campaign were to:

- Gain a better understanding of the geological setting in the right bank downstream of the dam axis, for which a separate report on this important topic was issued ([15]);
- Provide an update of the hydrogeological data and model;
- Provide an update of some geotechnical characteristics.

The additional program of investigations specified by TEAS included the following features:

- Surface geological mapping at a scale of 1:5000;
- Drilling: 4 boreholes totaling 608 m, and 35 permeability tests;
- Refraction seismic profiles: 3 lines, with a cumulative length of 2,380 m;
- Micro-gravimetry measurements: 684 stations over 25 profiles;
- Installation of 30 stations to monitor potential slope movements;

- Inspection of existing galleries, specially rehabilitated for this purpose;
- Discharges measurements, chemical analyses of springs;
- Piezometer drilling and measurements (19 piezometers installed and followed-up);
- Pumping-dissolution test of the Ionakhsh fault zone.

The entirety of the specified program was carried out during the course of the studies and duly incorporated in the assessment of the proposed project.

## 2 REGIONAL GEOLOGY

The HPP site lies at the junction of the southern Tien-Shan range and the uplifted northern ridges of the Afghan-Tajik Depression. The Tajik Depression unit, where the dam and appurtenant structures are located, consists of Mesozoic-Tertiary continental and marine sedimentary cover overlying the Paleozoic basement. Its northern limit is set by the regional Illiak-Vakhsh fault system (“Vakhsh Fault” in the project area). As a consequence of high compressive stresses and regional uplift, the Mesozoic-Tertiary sedimentary sequence, formerly deposited above the Paleozoic basement in the Afghan-Tajik basin, is now exposed in young mountain ranges.

The main structural elements are highlighted in Figure 2.

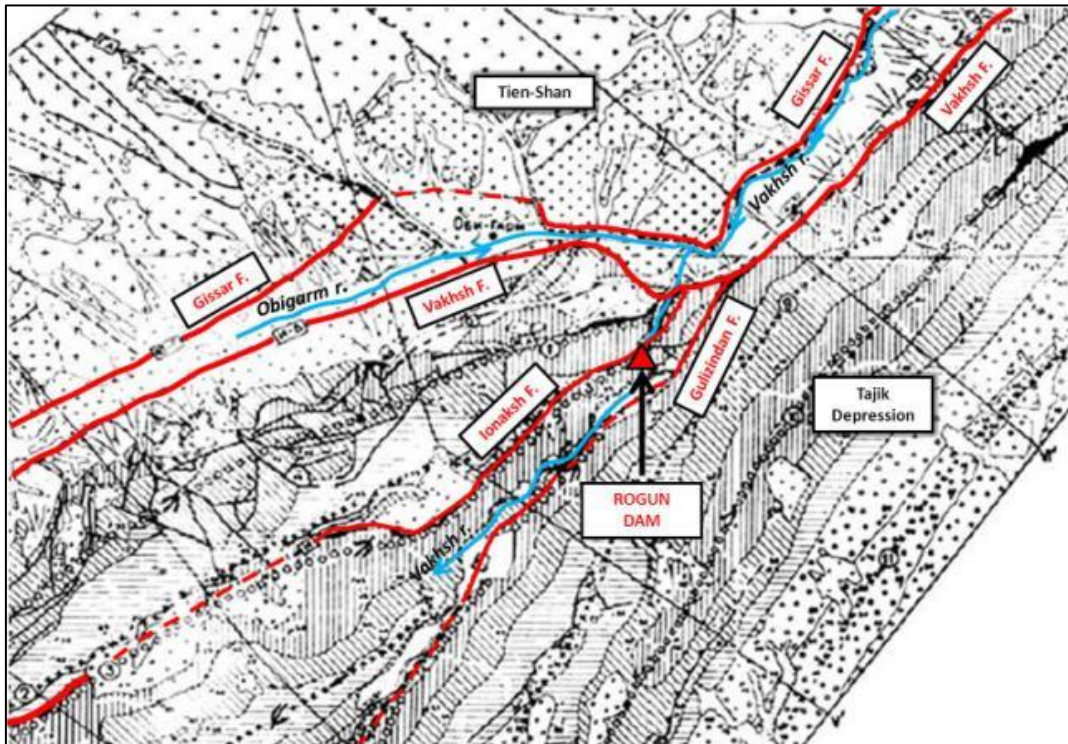

**Figure 2: Main faults near the project area**

Due to these high tectonic stresses in the project area, tectonic deformation takes the form of seismic displacement along faults, creeping, aseismic movements especially related with salt tectonics, and folding.

### 3 SITE GEOLOGY

At the dam site, the river channel is narrow and the valley profile has a relatively tight 'V' shape, with steep slopes. The favorable morphology of the retention structure is due to the river cutting across the general structural trend, as well as a result of the bedding.

#### 3.1 Lithology

The main lithological groups identified at the dam site are:

- Upper Jurassic salt formation (Gaurdak Formation): It is primarily composed of salt, subordinate gypsum, with a thin reddish mudstone layer at the top. Its maximum thickness on a regional scale is assumed to be 400 m. In the project area, it is shaped as a wedge truncated

by the Ionakhsh Fault. According to data from drilled boreholes and inspection of adits, the thickness of the wedge is assumed to increase by 15 m for every 100 m in depth.

- Lower Cretaceous continental sequence: This group, with its characteristic dominant reddish color, is mainly composed of sandstone, siltstone and mudstone layers, with only rare, generally thin, evaporitic layers. The thickness of this sequence at the dam site is in the range of 1,100m.
- Marine sequence, principally Upper Cretaceous: Composed of sandstone, siltstone and shales, this sequence is typified by the presence of limestone, marls and gypsum layers.

### 3.2 Geological Structures

The main structural trend on a regional and local scale is ENE-WSW. This orientation affects the bedding, major thrusts, and the axis of the only noticeable fold at the dam site, namely Kirbitch syncline. The vergence of thrusts is facing NNW. Accordingly, the thrusts and the bedding planes located away from the fold axis dip mostly to the SSE. At the dam site, the dip angle of the thrusts and of the bedding is generally high, exceeding 75° for the Ionakhsh Fault and 60° for the bedding of the monoclinical sequence downstream of the fault.

### 3.3 Faults and Major Discontinuities

#### General setting:

The analysis of available data suggests that the kinematic model, involving pure vertical uplift of the block between Ionakhsh and Gulizindan faults, schematically presented in the following figure, needs to be refined.

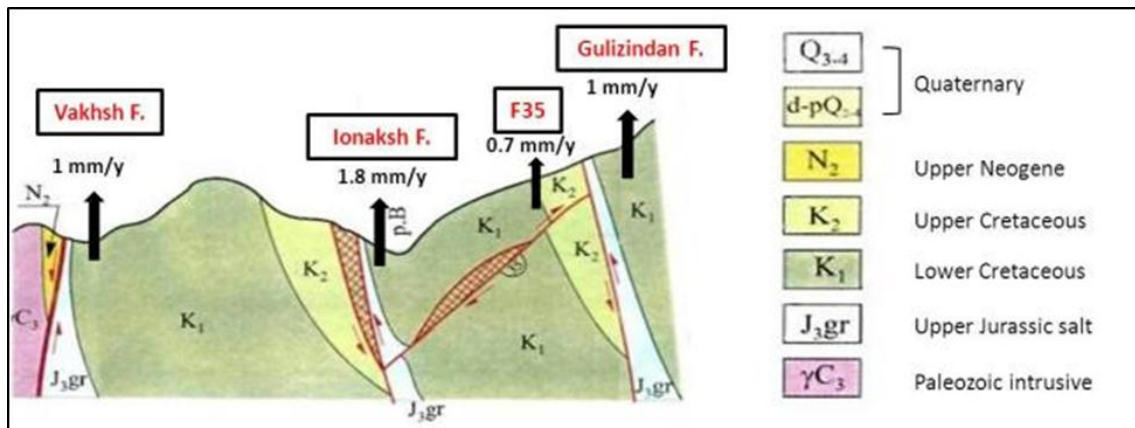

**Figure 3: Schematic Cross Section Showing Thrust Rates for Main Faults (modified from [3])**

The analysis of monitoring results concluded that the tectonic bloc delimited by the Ionakhsh fault and fault 35 is uplifted by an average of approximately 2 mm/year. However, the differential uplift recorded between different stations could indicate that the movement of the bloc as a whole is not pure uplift but could involve tilting. Such complex deformation could be accommodated by differential movements (rotation, tilting) of smaller blocs delimited by minor faults. An increased number of adequately positioned monitoring stations would help defining the actual kinematic model of the structure.

#### The Ionakhsh Fault

Recent investigations, including two boreholes and geophysical investigations, have been carried out during the course of the TEAS in order to complete the assessment of the fault at upper elevations. The fault zone is characterized by strongly sheared mudstones and gypsum (but no salt) in the hanging wall (Jurassic formation) and by breccia in the footwall (Upper Cretaceous). The thickness of the fault zone, which includes crushed rocks, highly disturbed gypsum and fault breccia is well in the order of several tens of meters (20 to 80 m in [1]). The thickness of gypsum in the fault zone varies from less than 1 m to over 5 m. It is rarely visible at surface.

According to a few tests carried out in boreholes IF1 and WRB2 at the upper elevations, the permeability values vary – they are low in the undisturbed setting in the dam abutment (IF1), and moderate to high in the overturned section (WRB2). Observations carried out in the grouting gallery of the right bank tend to confirm the water tightness of the hanging wall (on the downstream side) in the fault zone in the lower part of the abutment.



### The Gulizindan Fault

This fault is comparable to the Ionakhsh fault in its nature, attitude, size and order of magnitude of the slip displacement rate. Unlike the Ionakhsh Fault, it does not cross the dam foundation, but it runs parallel to the river valley, from the reservoir to the downstream side of the dam. Low permeability values measured in two boreholes and high velocities of P waves converged in showing the water tightness of the fault zone.

### Fault 35 and S4 joint set

Fault 35 is almost perpendicular to the river valley, and crosses it about 100 m downstream from the dam axis. Its attitude is 35-45°/330-340°, with an upstream dipping. Downstream, the fault becomes untraceable once it reaches the downstream right bank atypical zone with overturned sequence.

Several other major joints have a similar orientation to that of Fault 35, but have low or no offset, and cross the river valley and the dam foundation. The spacing between these discontinuities varies mainly between 20 and 60 m. Fault breccia and clay infill are usually several centimeters wide, but can reach up to 0.3 to 0.5 m in width. Among them, Fault 70 is reported to have a cumulative offset of 10 - 15 m.

All these faults and major joints belong to the joint family S4. Along with the bedding joints, the major fractures of this family are the most conspicuous at the dam site, generally persistent over hundreds of meters.

Joints of this family are unfavorable in the downstream walls of the caverns. The major fractures mentioned above have the same attitude across siltstones and sandstones. These fractures are mostly unfavorable for slope stability in the upstream part of the Left Abutment, in the area of the Diversion Tunnels. Gravitational sliding on such surface probably caused shearing of the lining at the inlet portal of the diversion tunnels. The risk of sliding along such discontinuities will increase with pore pressure increase during impounding or with significant fluctuation of the reservoir level.

### Sub-horizontal and Shallow Dipping Discontinuities

Sub-horizontal discontinuities are noticeable at many locations on the dam site. Their significance in the kinematic model is not completely clear, but decimetric offsets are often associated with such discontinuities, showing that they participate actively in the adjustment of the tectonic stresses.

### Transversal Faults

Fault 367 outcrops in the right bank of the Vakhsh River near the upstream cofferdam. Its attitude is NW-SE with a steep SW dip. The amplitude of displacement is only roughly estimated in [1] in the range of 150-200m. The width of the zone of crushed rock can reach 3-5 m, while the wedge of highly fractured rocks can be up to 70m wide. The Ionakhsh Fault cuts it to the SE.

A discontinuity in the same family is inferred from alignment of morphologic elements along the NE boundary of the atypical zone in the right bank. It was identified at the feasibility stage as Fault 24. Field observations, such as tight bending of the plastic layers and attenuation of offset in the lower part of the slope, do not confirm the presence of either a fault or continuous surface rupture.

## 4 SLOPE STABILITY IN THE DAM SITE AREA

### 4.1 Landslides Involving Quaternary Deposits

The analysis of slope stability, first reported in [1] has been updated in [13]. The main areas with past and potential landslides of Quaternary terrains are listed below:

- Left bank above intake tunnels. This area comprises large volumes of scree deposits. Their toe lies below the reservoir level, and the probability of sliding will increase after impounding. Usual mitigation measures are recommended at this stage: reshaping of the slopes where possible, drainage, water collectors, and retention structures.
- Right bank slopes of the atypical area. Thick accumulations of scree deposits, including an ancient landslide in the central part, are widespread on this slope. Drainage and reshaping of the slope are necessary.
- High scarps in alluvial terraces which lie in the left bank of the Vakhsh River, especially upstream between the mouth of Obi-Djushon and the canyon, on one side, and starting from the mouth of Obishur, downstream of the canyon. The scarps are 20-50 m high and can be affected by slides subsequent to caving by river erosion at their base. The erosion is mostly expected to be progressive, provided dissolution of salt along the Vakhsh Fault does not trigger larger slides, which is an unlikely scenario.
- In the right bank of the Passimurakho valley, two landslides are interpreted as an adjustment of the slope in response to salt dissolution at the base. They are considered in [1] as being typical of ancient landslides that are common in the reservoir area, and are described in the corresponding chapter.
- The area between the Passimurakho valley and the right bank of the Obigarm valley, which includes the city of Rogun and site installations, is characterized by an increase of salt deposits, karst dissolution and numerous superficial instabilities. Damages to buildings in Rogun city have been reported in relation to surface sinking, as discussed in the paragraph on reservoir geology. As for 'zone VI', the sliding and creeping processes, which are mostly superficial, are expected to develop progressively during impounding. The impact of impounding on dissolution and subsequent instabilities should be considered at detail design stage.

- In the upstream part of the right bank, in the area corresponding to the Kirbitch syncline and adjacent to the Ionakhsh fault, thick slope deposits could result in landslides of hundreds of thousands cubic meters.

#### 4.2 Potential Landslide Downstream in the Right Bank

Among the structurally controlled landslides, the Technical Design report described an ancient landslide in the atypical zone in the right bank, downstream of the site, with an estimated volume of 500 million cubic meters. (According to a recent reassessment from 2009 ([13]), the estimated volume of the ancient landslide would represent 75-100 million m<sup>3</sup>).

The assumed mechanism was a sliding of layers of a syncline limb along mudstone and gypsum interlayers. Recent investigations and observations during TEAS suggest that the configuration of this particular area results principally from tectonic deformation. The topic is presented in a separate report ([15]).

Based on the available, previous and recent data, the geological setting of the atypical zone in the right bank is a result of tectonic deformation, as opposed to the assumption of successive massive landslides and superficial creeping processes. The tectonic deformation could be related to décollement at evaporite layers located within the Upper Cretaceous sequence. One possible interpretation of the field observations is proposed on the figure below.

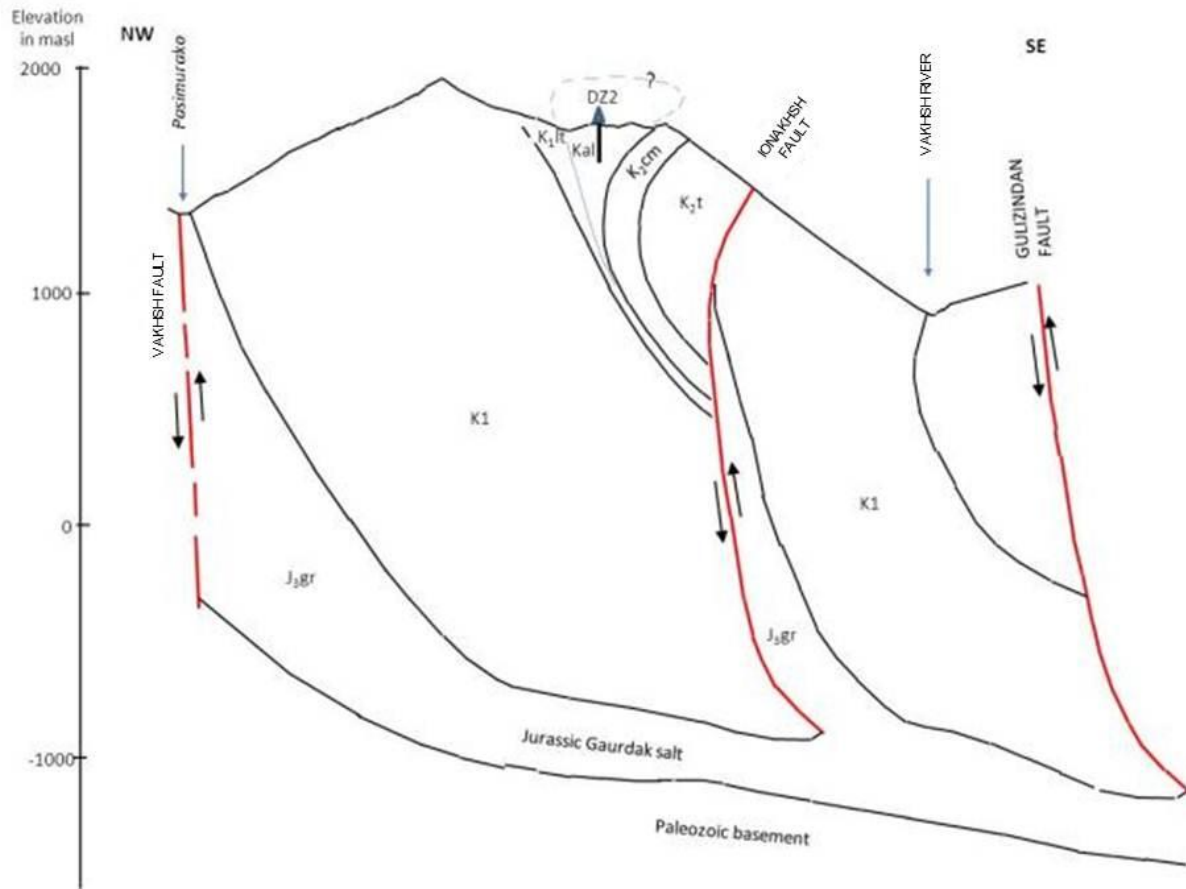

**Figure 4: Right Bank Interpretive Cross Section, view from the SW.**

This interpretation does not claim to reproduce reality accurately. Nevertheless, it integrates field evidence of complex folding on both a large and a small scale, thus putting forward the model of tectonic deformation to explain the geological setting of the atypical area.

Superficial processes such as karst dissolution, sinking and landslides also participate in reshaping the slopes of the atypical zone.

The new interpretation implies two important corollaries:

- The overturned Mesozoic sequence is not a consequence of dragging by ancient landslides, but of tectonic deformation. In the case of landslide dragging, the kink zone is a weak zone. Provided that the structural bending lies deep in the slope, as assumed at this stage, the tectonic origin is considered to be more favorable for slope stability.
- The NE boundary of the atypical zone ('Fault 24') would correspond to tight bending as opposed to a sharp discontinuity or fracture zone. In detail, the setting can be complex,

combining bending of the more plastic layers (argillite/gypsum) and brittle deformation of the more competent layers (sandstone). The nature and characteristics of this boundary are important for the layout and design of structures in this area. Additional investigations and monitoring are necessary in order to provide reliable input data for the final design.

### 4.3 Rock Falls

Even when slopes are stable on a large scale, rock falls are very frequent. They occur systematically with rainfall. Based on the joint pattern, the size of the blocks varies mainly from 0.3 to 2 m. This is already considerable, but even larger unstable rock masses are observed locally. The rock falls are a threat to the safety of personnel and can sometimes damage the structures. Standard mitigation measures are recommended in order to prevent such events – they involve cleaning of the most unstable blocs, support with rock bolts, anchors, and wire meshes.

## 5 ENGINEERING GEOLOGY

### 5.1 Weathering

Owing to the steep slopes, the products of rock weathering are progressively washed out, and the fringe of weathered rock is thin. Weathering only penetrates deeper along the open fractures.

Among the rock types, mudstones of Obigarm formation were reported to deteriorate rapidly after exposure. Fissures developed within 8 to 12 hours and penetrated up to 0.5m into the rock mass over the course of a day. The mudstones also exhibited slaking in the surface exposures and the turbidity produced by some wetted samples indicated the presence of dispersive clays.

Despite the sensitivity to weathering, it is estimated that the mudstones are hard to excavate below 0.5 to 1m. Among other rock types, the Jurassic reddish mudstones, sheared and mixed with gypsum, overlying the salt wedge, and the shales of the Liatoban and Turonian formations are probably the most sensitive ones to weathering and are prone to softening.



## 5.2 Fracturing

On a large scale, the bedding planes and the fractures of the S4 family form the most persistent and conspicuous discontinuities. These discontinuities mainly present planar surfaces. On a small scale, the rockmass is affected by three or more joint sets in various directions.

The rock mass is blocky to very blocky, with relatively well interlocked blocks. The interlocking is reflected in the steepness of the slopes.

According to available data, the filling material for the large majority of the joints is gypsum, in very thin coatings. The clay fill was mapped in very rare occasions, but observed on major joints during the inspection of existing galleries.

## 5.3 Hydrogeology

The results of hundreds of tests reported in [1] show that the rock mass at Rogun HPP has generally a low permeability. The permeability values were integrated as an important parameter for the geotechnical zoning, as summarized below:

- Class I, from surface to 7-40 m depth: 20 LU (approximate equivalent);
- Class II, 15-25 to 40-50 m thick below Class I, 1 to 3 LU;
- Class III, from a 20-80 m depth to a 60-140 m depth, 0.2 to 0.8 LU;
- Class IV, with upper boundary at a 60-140 m depth, and a permeability below 0.1 LU.

The anisotropy commonly related to the sedimentary sequences has not been much considered in this first assessment. Such anisotropy could be high in alternant sandstone / mudstone layers. However, at the Rogun HPP site, the high horizontal stresses probably neutralize much of the anisotropic effect. Roughly, this effect is estimated around one order of magnitude and concentrated locally.

Prior to the TEAS, there were only few piezometers set up in the dam foundation, most of them being located near the Ionakhsh Fault. A total of 19 piezometers were installed in the course of the present study to better understand the overall hydrogeological conditions of the site and allow for finer calibration of the models. The analysis of the results showed that the groundwater aquifer generally flows towards the river. In summer, when the river level is increased, the river charges

the aquifer in the abutments, following a gradient of about 3%. The estimated infiltration ratio is probably not exceeding 10% of the rainfall.

The particularities of the aquifer of the Ionakhsh Fault, as well as the issues related to the salt dome are discussed in the Phase 0 report.

#### 5.4 Engineering Geology Zoning

According to the original geotechnical zoning, four classes of rock mass are distinguished, based principally on weathering degree, condition of discontinuities, permeability and seismic velocities  $V_p$ :

- Class I primarily corresponds to the upper fringe of the foundation, where mudstones are weathered and clay infill is found on joints in sandstone. The thickness increases upwards from 7 to 40 m. The modulus of deformation, which is the lowest of all four zones, is estimated between 1.2 and 2.5 GPa.
- Class II rock underlies Class I. The thickness varies from 15-25 m near the river level to 40-50 m in the upper slopes.
- Class III rock and Class IV correspond to the deep-seated, slightly weathered and fractured rock mass. The upper boundary lies at 20-80 m below the surface for Class III and at 60-140 m for Class IV.

#### 5.5 Dam Foundation

The excavations, brought to a halt during a long stand-by period, will have to be resumed and ripped down to a level where the great majority of discontinuities are tight.

The impervious core is judiciously located in the mudstones of the Lower Obigarm formation. This thick sequence of mudstone layers has a naturally low permeability, in particular in the Class IV type of rock mass. For this reason, the proposed depth of the grout curtain seems adequate at this stage. Conversely, it is estimated that the lateral extent, especially in the right bank, cannot be defined precisely without determining the characteristics of the boundary of the atypical zone and carrying out additional permeability tests that shall be covered in the detailed design phase.

## 5.6 Powerhouse and Transformers Hall Caverns

The location of the two caverns was selected for them to be principally hosted by sandstones, and subordinately by siltstones. The location lies deep within the slope, away from the superficial influence and within the zone of steady in-situ stress. Among the major matters of concern are:

- The high convergence rates recorded over a long period after excavation in siltstones
- The proximity of the zone of influence of Fault 35.

The analysis of available joint pattern data emphasized the unfavorable configuration of S4 discontinuities.

Following the assessment of the powerhouse and transformers hall caverns complex, a possible set of stabilization measures was identified. However, the parties involved in the project agreed that further investigations of the rock mass parameters have to be performed, in view of the final design of the stabilization works. Thus, specimens of the siltstone rock mass surrounding the powerhouse cavern were collected, through Triple Core Barrel (TCB) Samples and Double Core Barrel (DCB) Samples. Also, cubic samples were obtained by using a saw machine.

The samples have been sent to rock mechanic laboratories, for performing tests including classification tests, triaxial compression tests, direct shear tests, triaxial multistage tests on saturated specimens and triaxial creep tests.

The tests are presently under finalization. According to a preliminary scrutiny, the results obtained so far seem to confirm the rock mass parameters adopted in the implemented 2D model of the Powerhouse complex.

## 5.7 Tunnels

At the present stage, the following aspects are considered relevant for the assessment of the geological conditions:

- The analysis of the disorders which affected the lining of existing tunnels
- The nature of the NE boundary of the atypical zone

### Disorders of the Tunnel Lining

Several disorders have been identified in different geological settings. Tentative explanations advanced so far involve the weakening of the rock mass due to (i) the proximity of the Ionakhsh fault zone, (ii) tectonic lens between Fault 35 and Discontinuity 111, and an anomalous high stress near major lithological contact.

These incidents in different geological contexts pointed out the need to investigate the thickness and condition of the lining by means of geophysical investigations. Such investigations have already been carried out at selected locations. They should be extended to the entire development of the tunnels.

### Nature of the NE Boundary of the Atypical Area

The data regarding the NE boundary of the atypical zone is insufficient for an accurate assessment of its nature and characteristics.

Based on field observations, the deformation along this lineament would be lower than the rupture across Fault 35. As a result, if tunnels are designed to cross Fault 35, they would also cross this boundary. If the design foresees crossing of Fault 35, the excavation of an exploratory gallery at the designed elevations would be necessary in order to inspect the boundary lineament and install monitoring devices.

## **6 GEOLOGICAL CONDITIONS IN THE RESERVOIR AREA**

The following features have potential influence on the design.

### **6.1 Evaporite Masses and Karst**

In the left bank of the river, some foothills of the Vakhsh Ridge are formed by evaporite rock masses aligned on the Vakhsh Fault. The visible part of these rock masses, with volumes amounting to several million cubic meters or more, is principally made up of gypsum, but the presence of salt at depth cannot be excluded. They were also identified in the valley of Passimurakho, which is the extension along strike of the Vakhsh Fault lineament. It is therefore possible that a salt diapir would underlie the interfluvium between Passimurakho and Obi-Djushon valleys. All these occurrences exhibit intensive karst dissolution features. Dissolution and the

formation of sinkholes can be accompanied by superficial landslides. Such processes have already led to the sinking of inhabited areas in the city of Rogun, causing damages to buildings.

## 6.2 Seismic Scarps

Evidence of Upper Quaternary and modern age earthquakes was found in the reservoir area. Analysis of aerial photographs carried out in [11] highlighted the presence of numerous features interpreted as seismic scarps spread over a segment of at least 15 km at the foot of the Vakhsh Ridge. Two of them deserve further analysis:

- Between the Tagikamar and Khodzhaalisho streams, the scarp could be linked to an ancient rockslide, with an estimated volume of roughly 10-15 Mm<sup>3</sup>, which could be (re)activated as water levels rise above the 1,250 m elevation.
- Westwards from Talkhakchashma village, a young scarp crosses the Tanakba gully. No scarp is visible in the continuity of this lineament in the right bank of the Vakhsh River, but landslides and karst processes occurring in the valley of Passimurakho could conceal the tangible evidence.

## 6.3 Slope stability

Significant potential slides have been identified, corresponding to a recent evaluation of slope instability (in ref. [11]).

However, it is estimated that the most important issue is related to the landslide mechanism described in [1], according to which ancient landslides, which can reach several hundreds of millions of cubic meters for major ones and 10 Mm<sup>3</sup> for common ones, were triggered by the dissolution of salt at the toe of the slope. Such landslides would mostly occur in the left bank, along discontinuities with attitudes similar to that of Fault 35, dipping by 40-60° towards the valley. Based on the observation that the overall structure of the rock masses is well preserved, it is inferred that the landslide developed at a low rate, similar to creeping. The two landslides in the right bank of Passimurakho, with estimated volumes of 20-30 million cubic meters, are given as examples.

## 6.4 Seepage from the reservoir

Because the Vakhsh River is the regional drainage base level, lateral seepage from the reservoir can be excluded.

The Gulizindan Fault, which runs parallel to the river valley on the left side of the dam, has been considered as the main potential waterway for leakage from the reservoir. However, the results of geological and geophysical investigations carried out in the right bank of the Obishur valley indicated that the fault was watertight. Taking this fact into account, a 1 km grouting gallery running along the Obishur valley is considered to be an adequate measure to prevent leakage from the reservoir along this fault.

## 7 CONCLUSIONS AND RECOMMENDATIONS

### 7.1 Investigations

The number of existing investigations is deemed sufficient to assess the feasibility of the project. However, additional investigations are recommended to address specific issues and for the completion of the detailed design:

- To determine the nature of the boundary of the atypical zone – excavation of the exploratory gallery, monitoring of the boundary zone under and over-ground. Additionally, the rehabilitation of gallery 1034 should be completed. If major fracture zones are crossed, both galleries could be equipped with devices to monitor the deformation.
- Piezometric levels – in particular in the upper part of the right bank, to design the grout curtain, and on the downstream slope, to design a drainage system to control the pore pressure: drilling with permeability tests and installation of piezometers.
- Geotechnical characteristics of construction materials
- Monitoring of slopes and fault displacements.

## 7.2 Seismic and Aseismic Deformation

At the Rogun HPP site, the regional tectonic stresses are adjusted by deformation which is both seismic, i.e. involving sudden co-seismic rupture, and aseismic, mainly by creeping. This creeping, which is permanent, takes place principally on the main faults, where monitoring was implemented to measure the deformation rate.

Special protection measures must be designed for the underground structures that cross the main discontinuities with evidence of significant shear. Nevertheless, field evidence and geological settings involved in areas where diversion tunnels supports are damaged suggest that the adjustment of tectonic stress is partially transferred by the diffuse deformation of discontinuities distinct from the main faults.

Additional investigations are recommended to verify the cause of damages to the supports at all identified locations. If necessary the rock masses should be exposed for inspection and installation of monitoring devices. Monitoring of displacements along the main faults should be resumed and additional devices installed. In addition, monitoring should be extended to the major discontinuities showing offset, which is consistent with present-day stress orientation.

## 7.3 Risk of Landslide

### Gravitational Sliding on S4 Discontinuities

In the left bank, in the upstream part of the dam, which includes the slopes above the diversion and water intake tunnels, the risk is related to gravitational sliding on day-lighting discontinuities of the S4 family. It is recommended that at detail design stage, the persistent joints are precisely identified and that stability calculations are carried out, taking into account the effect of increasing pore pressure upon impounding and fluctuation of reservoir level. Galleries filled with reinforced concrete across the discontinuities are possible mitigation measures among others for increasing the shear strength. This method has already been implemented successfully in other projects exposed to similar risks.



### Downstream from the Right Bank

Landslide involving slope cover deposits are not considered a major threat for the feasibility, but mitigation measures (i.e. slope reshaping, drainage) are compulsory to prevent that risk during construction and operation.

There is no evidence of the existence of unfavorable tectonic discontinuities that could cause massive structurally controlled landslides. Recent data showed that the geological setting results from slow, tectonic deformation. When compared to the initial landslide model, the present interpretation is more favorable to slope stability, taking into consideration the fact that the rock mass is less damaged during slow deformation.

Rising of pore pressure could occur locally in the atypical zone. It is therefore recommended that adequate drainage system be designed for the main slope downstream of the dam site. For this purpose, additional investigations are recommended to determine the permeability and the ground water level. These investigations should comprise a line of at least 5 boreholes in the atypical zone, starting at an elevation of 1350 m, 100-150 m deep, or sufficient to intercept the ground water level, spaced 100 m apart.

In order to detect and follow-up any slope movement in the atypical zone, potential displacements will be monitored from 30 geodetic stations, scattered on the upper part of the slope below the plateau. Readings will be performed from 2 base stations located on the opposite bank.

In conclusion, the geological setting is quite favorable for slope stability. The risk of rock mass failure could increase if mitigation measures for controlling the pore pressure are disregarded.

### Risk of Landslide in the Reservoir

Potential rockslides could be triggered by the dissolution of salt in the foot of the northern slopes of the Vakhsh and Surkhku Ridges. Near the dam site, such slides are still developing in the right bank of the Passimurakho valley.

The likelihood of slides occurring seems low, but cannot be disregarded without prior assessment, although such an assessment is difficult. The area posing the greatest risk is located upstream of the canyon and up to the mouth of Obi-Djushon, where salt rock masses will certainly be in contact with the reservoir.

The landslides are commonly preceded by several months of a progressive opening of cracks on the upper slopes. For this reason, the first recommended measure is to implement a program to monitor the slopes with visual inspection.

#### **7.4 Debris and Mudflows**

These flows are relatively common in the project area, and the risk has been examined since the initial project design, when the construction of a retention structure on Obishur valley had been considered. Severe floods have been recorded along this left-hand tributary, leading to temporary damming of the Vakhsh River.

Most of the mudflows occur during the rainy months of May and June. Between 1971 and 1991, they occurred at least once a year. Maximum volumes were estimated at around 3,100 million m<sup>3</sup> in 1983 and 1,185 million m<sup>3</sup> in 1992.

## **CHAPTER 2.3: GEOTECHNICS**

### **1 INTRODUCTION**

Geotechnical conditions of the site of the Rogun Hydropower Project has been extensively reviewed and analyzed, first in a global approach including the whole of the Works, then mainly in correspondence to their different components, with the objective of assessing the feasibility of the scheme.

This chapter provides a brief review of the geological and seismologic environment of the site, including findings from the results of the additional investigations made in 2011-2012 under the TEAS. This covers the Ionakhsh Fault and the salt wedge contained within it, and the monitored creep movement of this fault and Fault 35. Other specific tectonic features of the site and geodynamical issues (slope stability, mudflows) are presented.

### **2 GENERAL DESCRIPTION OF SITE AND INVESTIGATION PERFORMED**

The geological and geotechnical conditions of the different rock formations forming the dam and main works foundations are presented.

The results of previously performed in-situ stress measurements (mainly obtained through a kind of over-coring) exhibit in depth a maximum principal stress of up to 19 MPa oriented sub-parallel to the bedding of the series, while the vertical stress from the overburden is limited to 12 MPa. Given the high compressive stresses obviously acting perpendicularly to the main Ionakhsh and Gulizindan faults, one would have expected the maximum principal stress to be roughly perpendicular to the bedding. Distribution of the stresses on the dam site seems therefore rather counterintuitive and an update of the stress measurements using another technique is suggested to get more information where deemed necessary.

The nature and location of the different investigations performed (investigation galleries, boreholes, shafts, water tests), from where samples for testing were taken are presented. The definition of the different geotechnical zones (I to IV), according to their degree of weathering and distressing, and their proposed geometric distribution with depth are judged adequate.

A review of the available geotechnical data has been performed. Different sets of geo-mechanical parameters were defined for each rock formation, and for each geotechnical zone within the rock

formations. The sets are mostly composed of a synthesis of data from the original project of 1978, and some were completed with information acquired during the construction period. The exact way to determine the different geotechnical parameters is therefore not always clearly documented in available sources.

A review of the subsequent studies performed from the interruption of the construction up to date was then conducted, which revealed that the parameters applied to the original project of 1978 are largely used as a basis. In fact, most of the subsequent studies focus on updating the geotechnical parameters of the rock formations where the complex of underground caverns is being excavated, with several back-analyses of the experienced convergences being performed. Few new investigations were conducted over this period (mostly geophysics related to the underground works, because of the problem of the large amount of convergence in the cavern). HPI acknowledges this fact in its 2009 studies, and states that updating the geo-mechanical parameters of the dam foundation would be necessary, but mainly uses the same data from 1978 for its design.

Findings from site visits by the TEAS Consortium confirmed the overall validity of the 1978 data, although the estimated shear strength of the rock mass is slightly lower than the 1978 values. Geo-mechanical parameters to be used for underground works are proposed on the basis of the Geological Strength Index (GSI). The internationally known method makes it easy to adapt these parameters to other surface works by using the D parameter, which characterizes damage to the rock, and can be fine-tuned to obtain geotechnical parameters in the other geotechnical zones (weathered and distressed zones). Such sets of parameters can only be applied if the rock mass does not present a marked anisotropy with regard to the considered structure.

Site visits confirmed in particular the presence of several continuous faults over several hundreds of meters, with characteristics similar to that of Fault 35 (S4 joints), with a centimetric infilling of plastic clay observed in galleries. It is therefore obvious that for several structures, the stability analysis will require the shear strength of joints. A synthetic table of shear parameters are presented in the original project of 1978 (cohesion and friction angle of each joint set, and of joint infilling), but the way they were obtained is not documented, and updating such data by in-situ or laboratory shear strength over selected samples is necessary.

Globally speaking, it is recommended to perform a campaign of additional geotechnical tests, according to existing international standards, since such results will be valuable for international

contractors if, as recommended, the project were to be implemented and executed following International Competitive Bidding process.

### 3 HYDROGEOLOGY

With regard to hydrogeology, the review of the data from 1978 showed that, even if hydrogeological conditions were well assessed, the piezometers were mostly concentrated along the Ionakhsh Fault, and too scarce in number elsewhere to allow the real implementation of a map of the iso-hypses on the site (the map presented is of course based on available data, but extrapolated according to the topography over a large part of the site). The TEAS Consultant asked for piezometers to be drilled in 2011, mostly from the underground works, which confirmed the low gradient of the water table within the banks and the fact that water seepage occurs from the banks to the river during period of low waters, while it occurs from the river into the banks in period of high waters due to the seasonal variation of the difference between the watertable level in the banks and the water level in the river. The draining effect of the Ionakhsh Fault was also confirmed, but the presently available data must be completed by additional observation wells, because the existing ones are not sufficient to provide reliable groundwater levels over the whole site. Such data is required, especially to adjust the design of the grouting curtain.

Based on the data, a hydrogeological model of the site has been achieved for Stage 1 dam at elevation 1100, and for the dam alternative with crest elevation 1300. Although this model has to be improved at the stage of detailed studies, it gives an idea of the amount of leakage expected through the dam foundation, with a total value of 3,26 m<sup>3</sup>/s, which is acceptable given the scale of the dam.

Suggested improvements in the hydrogeological model are the extension to a larger area around the dam, including notably the disturbed zone of the right bank, the incorporation of some anisotropy of hydraulic conductivity due to the bedding joints, and some modifications in the boundary conditions. Calibration of the model is to be checked by taking into account all recently available data (piezometer recordings).

### 4 DAM FOUNDATION

The geotechnical characteristics of the dam foundation are globally found adequate to support the dam in its highest alternative (elevation 1300). Structural analyses of the foundation and stability

assessment show that the risk of failure of the foundation can be discarded. However, in order to limit potential leakages, care shall be taken to prevent possible entrainment of fine particles by water within the siltstone of the Lower Obigarm and the Kyzyltash Formation. This is assessed as manageable by means of the grouting curtain, which will reduce the groundwater gradient within the abutments. The presence of Lower Obigarm siltstones, which may rapidly alter into clay if unconfined and saturated by water, requires that the upper part of the foundation be removed just before placing the dam material.

Grouting of the foundation is to be performed under high pressure (or high Grouting Injection Number as per D. Deere and G. Lombardi if this method is applied), given the size of the final dam. It is to be completed by contact/consolidation grouting. The grouting curtain is contemplated down to Fault 35, without reaching it, in order to preserve the natural watertight barrier that its clay infilling naturally provides.

## 5 TECTONICALLY ACTIVE FAULTS

The problem of the tectonically active faults, either creeping at a rate of 1 or 2 mm/year, or susceptible of co-seismic displacement, has been examined. Even if the proposed TEAS design tries to avoid crossing such faults whenever possible, a limited number of hydraulic tunnels will have to intersect them. Such active faults have been defined as the Ionakhsh Fault, Fault 35, and some of the S4 faults between these two main faults (such as Fault 70).

Creeping or co-seismic displacement, which can reach 1 m in the case of the Ionakhsh Fault, is to be dealt with, and two solutions have been considered in order to allow the displacement to take place with no significant damage. Undermining of the embedding rock, cavitation and head losses, are three phenomena to fear if creeping or co-seismic displacement were to damage the lining. Undermining is the most serious one, since it could lead to the collapse and obstruction of the tunnel. The most likely solution to be adopted consists in increasing the thickness of the lining to 2 or 3 m, and enlarging the section to retain as much as possible of the section.

The potential impact of such fault movements on non-hydraulic structures requires local reinforcement of the support in the Works concerned, especially in the powerhouse where Fault 70 intersects it. The progressive tilting of the block between the Ionakhsh Fault and Fault 35, where the powerhouse and the main underground structures are located, calls for strict monitoring, and provision shall be made for an eventual realignment of the turbine axis.

In any case, the presence of such active faults will require regular inspection of the Works for as long as the dam will be in operation.

## 6 OTHER ISSUES

The following are specific issues which are related to geotechnics and are presented and analyzed.

The stability of the slopes along the S4 joints (family of Fault 35, continuous with centimetric clay infilling, with 40-60 m spacing) has apparently already proven to be an issue, since damages to the existing intake portals of the left bank diversion tunnels are most likely related to creep movement of the above slope along such a joint. It mostly affects the left bank upstream of the dam, to be subject to the variations of the reservoir level. Therefore, subsequent studies will have to locate precisely such joints and the design stabilization works is required. Solutions for slope stabilization in such conditions have already been designed and implemented in other projects with shear key excavated at regular intervals within the potentially sliding joints. Detailed investigations are used to determine the most appropriate way of achieving stabilization, which can combine shear keys (where the joint is well identified) to unloading and drainage of the slope (above reservoir level). Ensuring the long-term stability of these slopes is necessary, since they are located near or above the dam abutment and intakes.

The atypical area, downstream right bank, with its large plateau on the top, around elevation 1800, has been recognized to be of tectonic origin, which discarded the hypothesis of huge old landslides after the investigations of 2011-2012. Therefore, no mass movement of the whole zone is to be feared. However, since the slopes above the Vakhsh River sometimes present large masses of colluvium and scouring debris, slope stabilization measures shall be applied there as well, in order to avoid the sudden fall of a large mass which could obstruct the river downstream of the dam. Within this “atypical zone”, the Ionakhsh Fault is assumed impervious, therefore an increase of pore pressures within this zone should be limited, but shall be monitored in relation to the potentially unstable masses (whose movement is already monitored).

Mudflows from the Obi-Shur River, a left bank tributary of the Vakhsh River just downstream of the dam, occur almost yearly and, by damming the river in 1993, were partly responsible for the flooding of the already excavated underground works. A retention dam is currently being heightened, but a large part of the volume left by the dam at its present stage of construction has already been backfilled. Further studies are to be performed to determine if further dams with



improved efficiency may be necessary. The implementation of an efficient warning system is suggested, and should allow the staff on-site to swiftly take all precaution and close all gates in anticipation of a rapid rise of the downstream water level, in order to avoid flooding of the powerhouse.

Other related issues, such as potential landslides and mudflows in the reservoir area, have to be investigated on a case by case basis, and adequately treated where necessary. It has been verified that the impact of salt dissolution during the life of the scheme would not affect the dam, and no substantial leakage from the reservoir is to be feared.

For each of the structures suggested by the TEAS Consultant – mainly gate chambers of spillway tunnels and a large surface spillway – the expected geotechnical conditions have been analysed, and, although difficulties cannot always be avoided during construction work, these structures are deemed at this stage feasible, provided firstly that detailed studies and modeling are carried out to finalize their design and then adequate construction methods and monitoring are performed.

## 7 CONCLUSIONS AND RECOMMENDATIONS

In conclusion to the Geotechnics assessment, the Consultant underlines the necessary monitoring of the creeping faults and associated tilting movements of the blocks limited by these faults (notably, creeping also occurs along faults within the block), and the detailed study and design of stabilization measures of the potentially unstable masses along the upstream left bank and on the front slopes of the “disturbed zone” of the downstream right bank. These points are deemed very important.

Other recommendations include:

- Performing updated geotechnical investigations, according to internationally recognized standards, especially regarding the shear strength of the discontinuities,
- Securing the entire dam site before the construction is initiated, since rock falls occur very frequently (through scaling or adequate support),
- Backfilling the old investigation galleries or any other tunnel that may give way to undesirable water path after impounding,
- Renewing, if possible, stress measurements,

- Further studies are required for mitigation measures against mudflows from the Obi-Shur River.

Although the exact arrangement of the geological structures in this zone, below reservoir level, is not known, it is likely that leakage through hypothetical gypsum beds at this elevation is not possible, because of the presence of the watertight Ionakhsh Fault and of the absence of an outlet for such flow.

## CHAPTER 2.4: SEISMICITY

### 1 INTRODUCTION

This is a Summary of the independent Deterministic Seismic Hazard Assessment (DSHA) carried out as part of the techno-economic assessment for the proposed Rogun HydroPower Project (HPP). Its aim is to define the preliminary seismic design parameters, based on which the different dam alternatives have been assessed.

According to the Terms of Reference, at this phase of the study, the purpose of the seismic hazard assessment is to derive representative seismic parameters against which the safety of each dam alternative is to be ensured. The seismic design parameters adopted in this study are, therefore, being used as input parameters for the stability design of the project components of different alternatives.

The assessment also provides recommendations to reinstate the existing seismic network in the project area and ensure the proper monitoring of seismicity near the site before, during, and after the proposed construction.

It is also recommended that a comprehensive seismic hazard assessment dedicated to a selected dam alternative is conducted for the next phase of the project design. This assessment will be based on a state-of-the-art Probabilistic Seismic Hazard Assessment (PSHA).<sup>1</sup>

This summary presents the deterministic seismic hazard assessment performed by the Consultants, and the proposed seismic design parameters derived.

### 2 GLOBAL TECTONIC FRAMEWORK

The Rogun HPP is located within the region of the India-Asia collision and, more accurately, north of the western syntax of the Himalayan range (Tajikistan) in an exceptionally complex tectonic

---

<sup>1</sup> Although not part of the Phase II study, an independent Probabilistic Seismic Hazard Assessment (PSHA) has been carried out for the project for use in the detailed design stage. For the design parameters obtained from the PSHA, a preliminary analysis has shown that the dam response and displacements are within the limits obtained from the analysis performed with the DSHA design parameters for the Phase II study.

area. The global tectonic framework and relative movements of the different tectonic blocks are shown in Figure 5.



**Figure 5: India-Asia collision and induced deformation within Eurasia. Rogun HPP is located within the western syntax of the Himalaya, characterized by intensive shortening.**

### 3 GEOLOGIC CONTEXT

The proposed Rogun dam site and reservoir are located within the Tajik Depression, more precisely within the Vakhsh Range, which is a portion of the active deformation zone resulting from the Cenozoic collision between the Indian and Eurasian tectonic plates. Crustal shortening between the Pamir and Tien Shan mountain ranges is an important consequence of this India-Eurasia convergence.

The Tajik Depression unit (TD) consists of Mesozoic-Tertiary continental and marine sedimentary cover overlying the Paleozoic basement. The fold-and-thrust belt appears to be controlled by décollement above the Jurassic salt. Geomorphic observations in this area provide evidence for significant Quaternary activity along faults within the TD.

Because available 1:200 000 scale geological maps and associated cross-sections do not allow the derivation of both fault geometries and mechanisms of deformation at an adequate resolution in the close surroundings of the dam site, and because the northern edge of the Tajik Depression appears quite cylindrical from the Vakhsh Range to the Peter First Range (PFR), we used the works of Hamburger et al. (1992) on the northern edge of the PFR to understand the regional geological structure and more specifically the involved mechanisms of active deformation.

Hamburger et al. (1992) have proposed two contrasting structural models of the north-western border of the PFR a few kilometers upstream from the Rogun dam site (Figure 6).

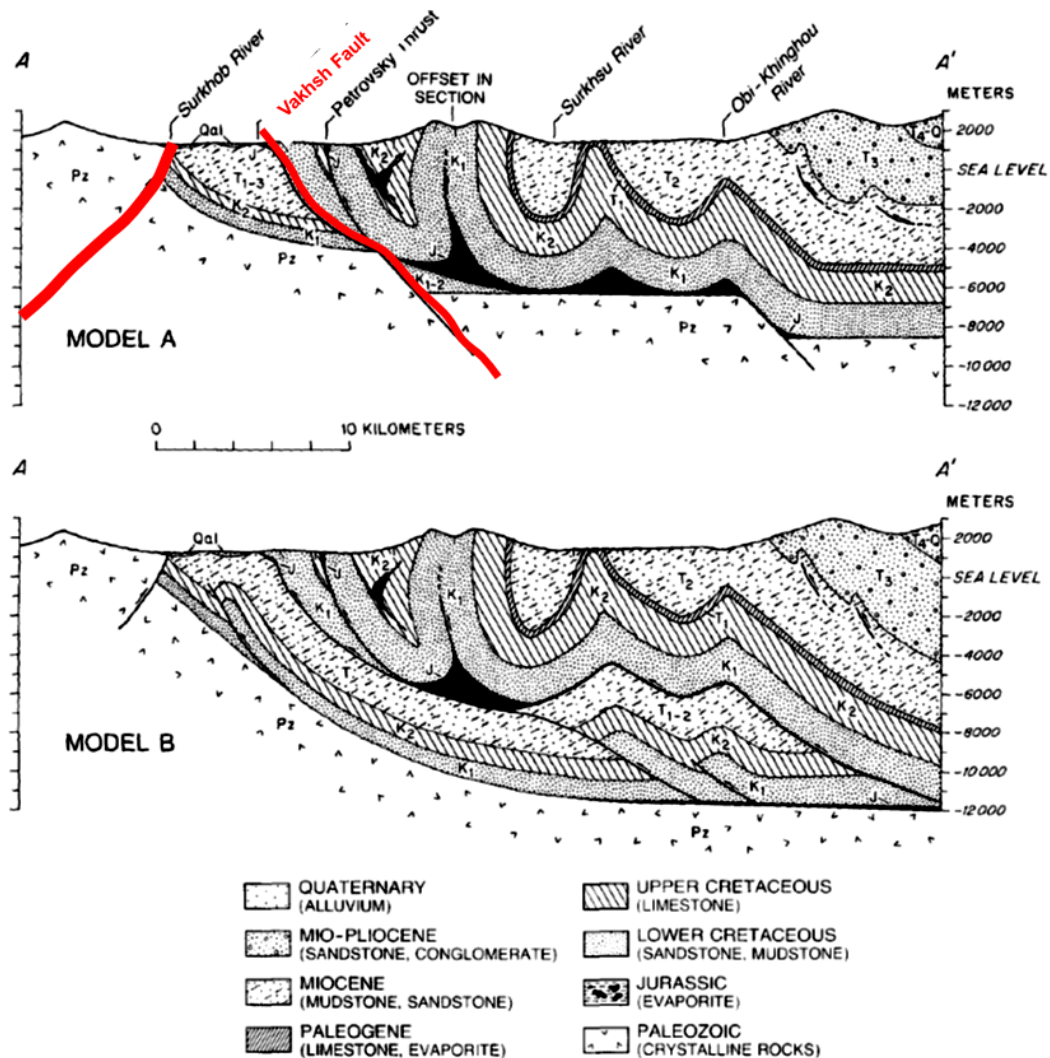

**Figure 6: Two interpretations of subsurface geological structure in the PFR**

Even if Hamburger et al. (1992) favor model B, they admit that available evidence cannot directly prove or contradict either of the models. The occurrence of seismicity deeper than the décollement supports the presence of crustal faults beneath the décollement (model A). This model is assumed to be representative of mechanisms of active deformation at the Rogun site and it is adopted for the present diagnosis.

The geological structures at the dam site are discussed in the dedicated geological report of the TEAS. The relevant faults for the seismic hazard assessment are:

- The crustal deep faults: Guissar Faults and Vakhsh Faults

- Regional, internal faults of the Tajik Depression: Ionakhsh Fault, Gulizindan Fault
- Local faults: Fault 35, Fault 70.

## 4 SEISMICITY

### 4.1 Regional seismicity

The Pamir and Tien-Shan mountain ranges are marked by significant seismicity, involving crustal earthquakes concentrated along the fault systems that form their boundaries (the Gissar-Kokshal fault zone and the Darvaz-Karakul fault zone). In addition, a dense concentration of moderate to small-magnitude seismic activity is observed within the thick sedimentary fill of the Tajik Depression fold-thrust belt.

### 4.2 Connection of major historical earthquakes with major faults in the surroundings of the dam site

The analysis of past earthquakes has been based on:

- the extensive report of Babaev et al. (2005) entitled “Seismic Conditions on the Territory of Tajikistan”
- the Hydrospectproject technical report n°2360-BTK2-001 (2005)
- the Central Asia Seismic Research Initiative (CASRI) earthquake catalogue (1895-2005), provided by the Institute of Earthquake Engineering and Seismology of Dushanbe.

Macroseismic data has been studied for major earthquakes associated with the main seismogenic structures near the project area. These structures are:

- the Gissar-Kokshal fault system
- the Vakhsh-Illiak fault
- the Ionakhsh and Gulizindan faults.



## 5 ASSUMPTIONS FOR DSHA

As a result of the seismotectonic diagnosis, the following assumptions on the Maximum Historical Earthquake have to be taken into account to assess the seismic hazard for the feasibility study of the various design options of the proposed Rogun dam.

Fault	MHE (M <sub>w</sub> )	Depth	Epicentral distance	Reference earthquake
Guissar	7.4	10 km	7-8 km	October 21, 1907 July 10, 1949
Vakhsh	6.4	10 km	4-5 km	September 16, 1924
Ionakhsh and Gulizindan ramps	5.9	5 km	4-5 km	September 22, 1930 January 22, 1989

**Table 1: Maximum Historical Earthquake (MHE)**

The above MHE values are further taken into account in DSHA at the Rogun dam.

Considering the epicentral distance of the reference earthquake relative to the dam site: these have been derived taking into account: (i) the Hamburger cross-section representative of the mechanisms of deformation, (ii) the actual location of the fault traces close to the dam site and (iii) conservative assumptions on the mean dip of the fault (70°).

The following figure illustrates the principles of these assumptions:

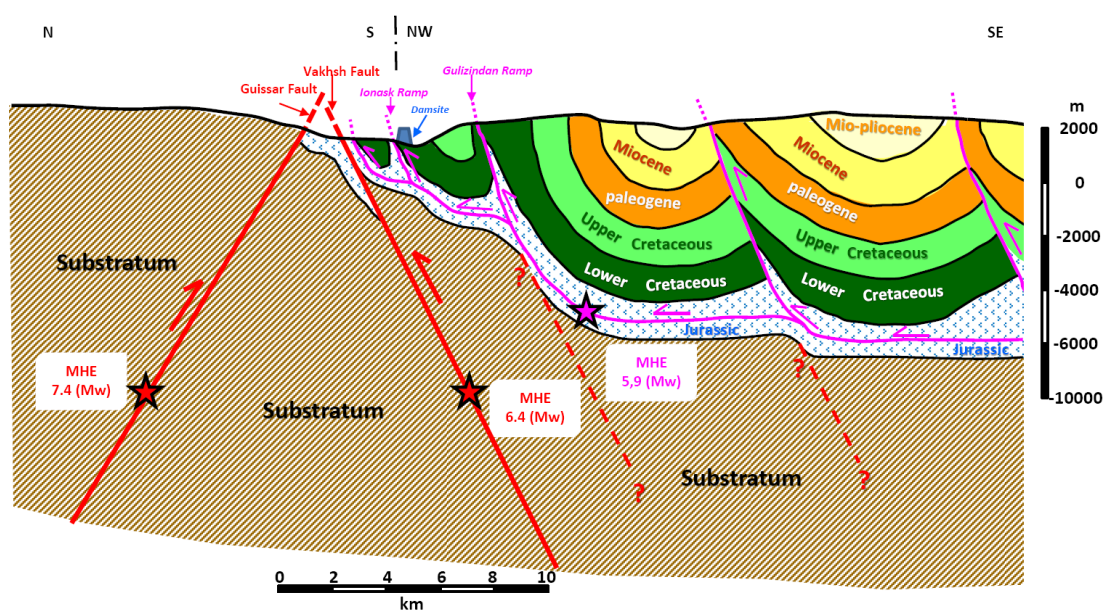

**Figure 7: Synthetic assumption for Maximum Historical Earthquake**



## 6 SEISMIC HAZARD ASSESSMENT

### 6.1 Estimate of the Maximum Credible Earthquake (MCE)

There are two ways to calculate ground motion associated with the MCE:

1. MCE=MHE increased by 0.5 magnitude units and ground motion parameters taken as the median plus half a standard deviation;
2. MCE=MHE and ground motion parameters taken as the median plus one standard deviation.

For this Seismicity study, it has been decided to take the conservative approach of calculating Peak Ground Acceleration (PGA) with the two methods and choosing the most severe results as the ground motion expected at the dam.

Distances, depth and magnitudes proposed for the largest expected earthquakes in each earthquake source are presented in the following table. Joyner-Boore and rupture distances are calculated taking into account the dip of the faults and the surface ruptures (downdip rupture width) estimated from the equations of Wells & Coppersmith (1994) with the magnitudes  $M_w$  for MHE and MHE+0.5, as given in the following table:

Seismogenic source	MHE	MHE + 0.5
	Depth, width, distances to the site, $M_w$	Depth, width, distances to the site, $M_w$
Guissar Fault	$M_w=7.4$ Focal depth = 10 km Down-dip rupture width=26 km Joyner-Boore distance = 5 km Rupture distance = 5 km	$M_w=7.9$ Focal depth = 10 km Down-dip rupture width=42 km Joyner-Boore distance = 5 km Rupture distance = 5 km
Vakhsh Fault	$M_w=6.4$ Focal depth=10 km Down-dip rupture width=10 km Joyner-Boore distance = 2.3 km Rupture distance = 6.2 km	$M_w=6.9$ Focal depth=10 km Down-dip rupture width=16 km Joyner-Boore distance = 1 km Rupture distance = 3.4 km
Ionakhsh and Gulizindan ramps	$M_w=5.9$ Focal depth=5 km Down-dip rupture width=6 km Joyner-Boore distance = 0 km Rupture distance = 2.4 km	$M_w=6.4$ Focal depth=5 km Down-dip rupture width=9 km Joyner-Boore distance = 0 km Rupture distance = 1.1 km

**Table 2: Estimate of the Maximum Credible Earthquake (MCE)**

PGA and response spectra are calculated according to three recent ground-motion prediction equations (GMPEs) selected from among the most representative for active shallow regions (Bommer et al., 2010) as given in the following table:

Id	Name	Distance	$V_{s30}$ (m/s)
ab10	Akkar & Bommer (2010)	Joyner- Boore distance	>750
ba08	Boore & Atkinson (2008)	Joyner- Boore distance	1000
cb08	Campbell & Bozorgnia (2008)	Rupture distance	1000

**Table 3: PGA and Response Spectra, Bommer et al., 2010**

For each earthquake's sources, the horizontal geometric-mean PGAs assuming a reverse focal mechanism were calculated. The site is on the hanging wall for the Vakhsh and Ionakhsh faults (cf. Figure 7). Results are given for the two methods of calculation described above, and for each GMPE in the following tables.

MCE=MHE+0.5 / median PGA + 0.5 standard deviation			
GMPE	PGA for Guissar Fault (g)	PGA for Vakhsh Fault (g)	PGA for Ionakhsh and Gulizindan ramps (g)
ab10	0.53	0.64	0.59
ba08	0.46	0.59	0.57
cb08	0.47	0.91	0.99
Average of the three GMPEs	<b>0.49</b>	<b>0.71</b>	<b>0.71</b>

**Table 4: Horizontal Geometric-mean PGAs, MCE=MHE+0.5 /median PGA + 0.5 standard deviation**

MCE=MHE / median PGA + 1 standard deviation			
GMPE	PGA for Guissar fault (g)	PGA for Vakhsh Fault (g)	PGA for Ionakhsh and Gulizindan ramps (g)
ab10	0.78	0.78	0.67
ba08	0.55	0.55	0.60
cb08	0.59	0.78	0.78
Average of the 3 GMPEs	<b>0.64</b>	<b>0.70</b>	<b>0.68</b>

**Table 5: Horizontal Geometric-mean PGAs, MCE=MHE / median PGA + 1 standard deviation**

The proposed MCE corresponds to the most severe earthquake scenario, which is the following:

- Maximum Historical Earthquake on the Vakhsh Fault with a magnitude  $M_w$  6.9 and a focal depth of 10 km placed at the shortest distance to the dam site (rupture distance ~3.5 km)
- $PGA = 0.71g^2$  (calculated based on the median plus a half of standard deviation:  $0.585g + 0.125g$ ).

## 6.2 Response Spectrum at Dam Site

The response spectra associated with the Vakhsh Fault and Guissar Fault have been estimated in the same way. The proposed response spectra for 5% damping (cf. Figure 8) have been calculated using the GMPEs of Akkar and Bommer (2010, ab10), Boore and Atkinson (2008, ba08) and Campbell and Bozorgnia (2008, cb08).

As shown in Figure 8, the Guissar Fault and Vakhsh Fault appear to provide similar level of pseudo-spectral acceleration taking into account the precision associated to the method employed. Special care has to be taken for the range of periods from 0.3 to 2 seconds corresponding to the periods of the dominating Eigen modes of the dam.

---

<sup>2</sup> In accordance with the instrumental seismic scale of the US Geological Survey EEIS, PGA values obtained are within the range of  $6,5 \text{ m/s}^2$  (0.64g) to  $12,4 \text{ m/s}^2$  (1.24g) which would correspond to intensity of 9 points on 12 points scale. Such relation may be used for communication purposes. However the dam design must be based on acceleration values and cannot be based on intensity.

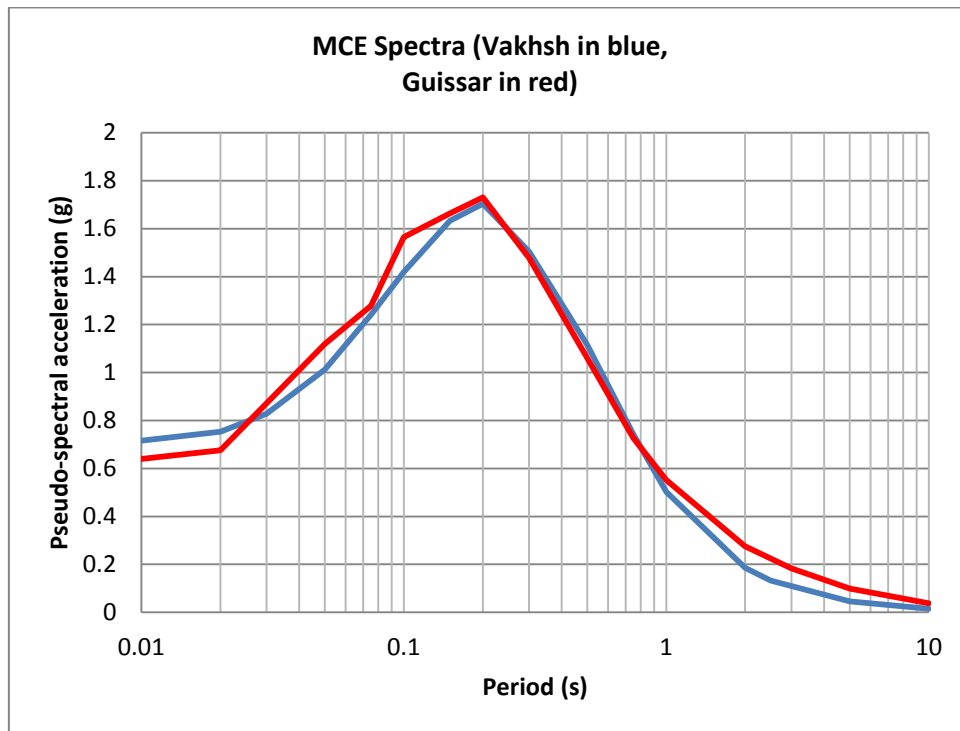

**Figure 8: Comparison between the proposed response spectra for 5% damping associated to both the Guissar and Vakhsh faults.**

### 6.3 Co-Seismic Displacements Potentially Affecting the Dam Foundation

Co-seismic displacement on critical faults was evaluated according to Wells & Coppersmith (1994) relationships for reverse faulting.

Taking into account their location and attitude (orientation), the Gissar-Kokshal fault system, Illial-Vakhsh thrust system and Gulizindan ramp cannot generate co-seismic rupture directly in the dam foundation. On the contrary, the co-seismic ruptures associated with (i) Ionakhsh ramp and (ii) internal deformation of the block between Ionakhsh and Gulizindan ramps are considered relevant for Rogun HPP structures.

#### **For the Ionakhsh ramps:**

Taking into account the location of the Ionakhsh ramps in the upstream part of the dam foundation, a first appraisal of potential co-seismic displacement along the Ionakhsh ramp associated with the MCE (Mw 5.9) has been conducted. In this study, both the average and the maximum displacements (mean and mean  $\pm 1\sigma$ ) derived for reverse faulting (Wells and Coppersmith, 1994)

are estimated. At this stage it is assumed that all significant co-seismic displacement occurs on the main fault plane. Estimates are reported in Table 6.

<b>lonakhsh ramp (5.9 Mw)</b>	<b>Mean value - 1 standard deviation</b>	<b>Mean value</b>	<b>Mean value + 1 standard deviation</b>
<b>Maximum displacement</b>	0.28 m	0.74 m	1.95 m
<b>Average displacement</b>	0.22 m	0.54 m	1.30 m

**Table 6: Estimates of co-seismic displacements associated with the MCE on the lonakhsh ramp.**

These estimates show large uncertainties. A conservative scenario would be to adopt the value obtained throughout the maximum displacement value at the mean-plus-one-standard-deviation. Based on present knowledge, one cannot disregard that part of the displacement occurs by creeping and/or by secondary faulting. This point should be carefully considered during the next stage of the design.

### **Dam foundation between lonakhsh and Gulizindan ramps**

Potential internal deformation of the block between the lonakhsh and Gulizindan Faults also has to be considered since it forms the foundations of the dam and its appurtenant structures.

Intense shortening of the Mesozoic cover can be assumed to have caused the formation of antithetic faults (back thrust) such as Fault 35, allowing for the upwards extrusion of blocks.

Based on such assumptions, shearing along these secondary faults are very likely disconnected from deep seismic rupture along the lonakhsh and Gulizindan ramps (faults) and may be interpreted as stress relaxation within the hanging wall post-dating the earthquake event. Taking into account the limited extension of these faults (a few hundred meters), the Consultants consider that the maximum incremental displacement should be around a tenth of the deformation on the bounding fault and thus remains of the order of 10-20 cm.

## 6.4 Design Earthquake for the Construction phase

The PSHA will furnish response spectra for various periods of return that will allow assessing, during the detailed design phase, the stability and safety conditions of the dam and other structures during the construction and operation of Rogun.

## 7 RESERVOIR TRIGGERED SEISMICITY (RTS)

Reservoir-triggered earthquakes have shallow focal depth, relatively small magnitudes, and often occur shortly after reservoir impounding or following sudden reservoir water-level fluctuations. Generally, on the basis of existing case histories, these earthquakes have magnitudes of less than 5. Based on the World data, maximum observed magnitude clearly related to the RTS was 6.3 (excluded Sichuan/Wenchuan Mw 7.9 China 2008, and Lake Hebgen Ms 7.1 USA 1959). This magnitude was registered at Koyna, 1967, reservoir volume 2.78 billion m<sup>3</sup>.

Another way of seeking to assess the chance of triggered seismicity from the proposed Rogun dam is to look at the seismicity connected with existing dams in the same region. In Tajikistan, the Nurek dam is one of the first large dams with seismic records before and after impounding (Simpson & Negmatullaev, 1981; Keith et al 1982). The seismotectonic setting for Nurek is similar to the setting at Rogun. In the case of the Nurek dam, recorded seismicity is in the magnitude range 1.4 to 4.6. The most intense bursts of increased seismicity were related to rapid increases in water level during the first stages of filling. The largest earthquakes all followed decreases in the filling rate of approximately 0.5 m/day (Simpson & Negmatullaev, 1981). An increase in seismicity is not observed on the major faults near the dam (Keith et al., 1982).

It is therefore expected that the maximum magnitude generated by the RTS at the Rogun site is likely to be less than 5. Higher earthquakes could be observed if the changes in the stress field affect the closest active faults, but this will not increase the maximum magnitude on the faults. Maximum observed magnitude clearly related with a dam is 6.3. It is recommended to undertake a slow filling of the reservoir in order to minimize the impact of the RTS.

## 8 PROPOSED SEISMIC MONITORING

In the context of Rogun, two types of seismic instrumentation are proposed:

- **a strong-motion network** (accelerometers) to survey the seismic behavior of the dam under strong earthquakes. For this purpose, accelerometers need to be located in the free field away from the dam, in the dam abutments and in the dam body.
- **a microseismic network** around the dam and in the reservoir region, which could record the background seismicity prior to the start of dam construction (at least two years before is generally the time period recommended) and the seismicity during construction, the first filling of the reservoir and the subsequent years of reservoir operation. Instruments should be digital seismic stations with velocity sensors. The number of instruments and geographic distribution depend on the desired threshold magnitude, the size of the reservoir and the regional seismic network already in place. Six to eight stations seems to be a minimum. A distribution of one station every 5 km is required if the network is to detect events as low as  $M \sim 1.0$ .

The TEAS Consultants recommend implementing this seismic monitoring as soon as possible in order to estimate the background (baseline) seismicity prior to the dam construction.

## 9 CONCLUSIONS AND RECOMMENDATIONS

Based on a deterministic assessment, the Consultants have concluded that the proposed Maximum Credible Earthquake (MCE) is the following:

- Maximum Historical Earthquake on the Vakhsh Fault with a magnitude  $M_w$  6.9 and a focal depth of 10 km placed at the shortest distance to the dam site (rupture distance  $\sim 3.5$  km)
- Peak Ground Acceleration = 0.71 g (calculated based on the median plus a half of standard deviation).

For the seismic design of the different structures and elements of a large dam project, ICOLD (2010) recommends defining the following design earthquakes:

- Maximum Design Earthquake (MDE)
- Safety Evaluation Earthquake (SEE)



- Design Basis Earthquake (DBE)
- Operating Basis Earthquake (OBE)

The design criteria are associated to return periods of earthquake ground motion. In the future detailed dam design phase, such design criteria can be derived from the Probabilistic Seismic Hazard Assessment that has already been carried out as an independent study, taking into account epistemic uncertainties associated with the assumptions and the choice of parameters and procedures.

The Consultants also recommend implementing seismic monitoring as soon as possible in order to estimate the background (baseline) seismicity prior to a start of dam construction.

## **CHAPTER 2.5: METEOROLOGY, HYDROLOGY AND CLIMATE CHANGE**

### **1 INTRODUCTION**

The proposed Rogun Hydroelectric Project site is located on the Vakhsh River which flows from the Pamir Mountains. At the proposed Rogun dam site the Vakhsh drains a catchment area of 30 390 km<sup>2</sup>. Approximately 30% of the catchment lies above 4000 m.a.s.l. within the snow and glacier cover zone (including Fedchenko Glacier, the longest glacier in the world outside of the Polar Regions).

The projected dam site is located 74.6 km upstream of Nurek dam, and will constitute the most upstream dam of the current Vakhsh Hydropower Cascade System. Further downstream, the Vakhsh River joins the Pianj River issued from central Pamir; together they form the Amu-Darya River, which is a main tributary of the Aral Sea.

The Vakhsh catchment is mainly controlled by snowmelt and glacier contribution. The region has a continental climate characterized by a wide temperature range during the year. A particular feature of the climate of central Asia is that maximum precipitation occurs in winter. Approximately 60% of the annual precipitation falls in February and March.

The Vakhsh River exhibits a typical snowmelt- and glacier-driven hydrological regime. The high-flow season peaks in July and lasts for 200 days in average.

### **2 INPUT DATA**

The design studies were based on the following Gauging Stations found to be the most representative and reliable among the extended Tajik network:

River	Station location	Catchment area (km <sup>2</sup> )	Observation Period
Surkhob	Garm	20 000	1932-1994
Surkob	Ustye	22 840	1973-present
Vakhsh	Komsomolabad	29 500	1942-1957 1975-present
Vakhsh	Rogun Dam Site	30 390	1973-1977
Vakhsh	Tutkaul kishlak	31 200	1930-1967
Obihingou	Tavildara kishlak	5 390	1953-present
Obihingou	Ustye	6 660	1941-1975

**Table 7: Gauging stations**

Inflows at the proposed Rogun Dam site are issued from the following sources over a long period that lasted 76 years:

1932 to 1972 – discharge recorded at Tutkaul gauging station,

1973 to 1988 – discharges at Tutkaul reconstituted from observations made at Komsomolabad. Correlations between the two stations are based on periods of common recording (1949-57 and 1963-72),

1988 to 2008 – discharges calculated based on Nurek HEP inflows issued from Nurek maintenance service.

The quality of the observed data was confirmed to be generally consistent and reliable by the present studies, and by previous designers. The accuracy of the long-term average inflow to the proposed Rogun site was judged acceptable as an input for the simulation of reservoir operation and future power production.

### 3 FLOOD STUDY

The flood study was carried out based on recorded daily and instantaneous peak discharges, daily temperatures and monthly / seasonal temperatures. Because records obtained for the Vakhsh River at Tutkaul and transposed to the proposed Rogun site were too short to assess floods for

large return periods, the station-year approach was used as a pooling methodology to extend the flood discharge sample, using the Francou-Rodier Index.

The statistical analysis was carried out on three different flood samples: Vakhsh records only for the first sample (111 station-years), and the Vakhsh series extended with data from rivers with similar hydrological regimes and climate conditions close to that of a mountain range, for the next two samples (249 station-years and 287 station-years). The analysis first favored time series within the catchment of interest, and then records from reference gauging stations in close climatic and geographic conditions with long time series. A cluster analysis of the series of data considered has been carried out to confirm that the approach was consistent.

The following conclusions were drawn from the analysis. They are consistent with previous studies and it should be noted that in the end, the adopted values were derived from the indigenous set of data (111 station-years of Vakhsh):

T	Synthesis of Results	
	Qp	Qdmx
2	2 360	2 250
5	2 780	2 650
10	3 070	2 930
20	3 360	3 200
50	3 750	3 580
100	4 030	3 840
200	4 310	4 110
500	4 660	4 440
1 000	4 950	4 720
2 000	5 260	5 010
5 000	5 640	5 380
10 000	5 970	5 690

*T in years; Qdmx and Qp in m<sup>3</sup>/s.*

**Table 8 : Synthesis of Flood Frequency Analysis**

#### 4 PMF ASSESSMENT

In this particular case, a conventional approach could not be followed for the Probable Maximum Flood (PMF) assessment, because the Vakhsh discharge is mostly uncorrelated from the precipitation. The Consultant derived its own approach with the use of the Degree-day method where the Degree-day factor was correlated to the discharge observed in Vakhsh to determine the

PMF. Temperature data was taken from Anzob Pass, which is considered as the most representative station of the data set.

The following input data were found relevant and representative: daily discharges at Tutkaul / Sarygusar, daily temperatures at Anzob Pass, and seasonal precipitation at Tavildara. The availability of data resulted in the selection of a 40-year period from 1940 to 1980.

For each year of the 40-year period, the degree-day factor was computed and a correlation was performed between the maximum daily discharge and the degree-day factor. Meaningful linear correlations with significant  $R^2$  were obtained. The parameters of the linear relations varied from one year to the next but are related either to the seasonal precipitation or to the degree-day factor for the occurrence of flood peak.

Making use of these different features, the Consultant was able to perform several maximizations in line with accepted procedures (WMO and others). The final choice of PMF was based on all available information and can be considered as conservative since the value was chosen as the highest value resulting from these maximizations. Computation of flood hydrographs was based on three major observed floods at Tutkaul.

	PMF (daily)	PMF (peak)
	(m <sup>3</sup> /s)	(m <sup>3</sup> /s)
<b>Proposed PMF</b>	<b>7 770</b>	<b>8 160</b>

**Hydrographs for 10 000-yr Flood and Probable Maximum Flood**

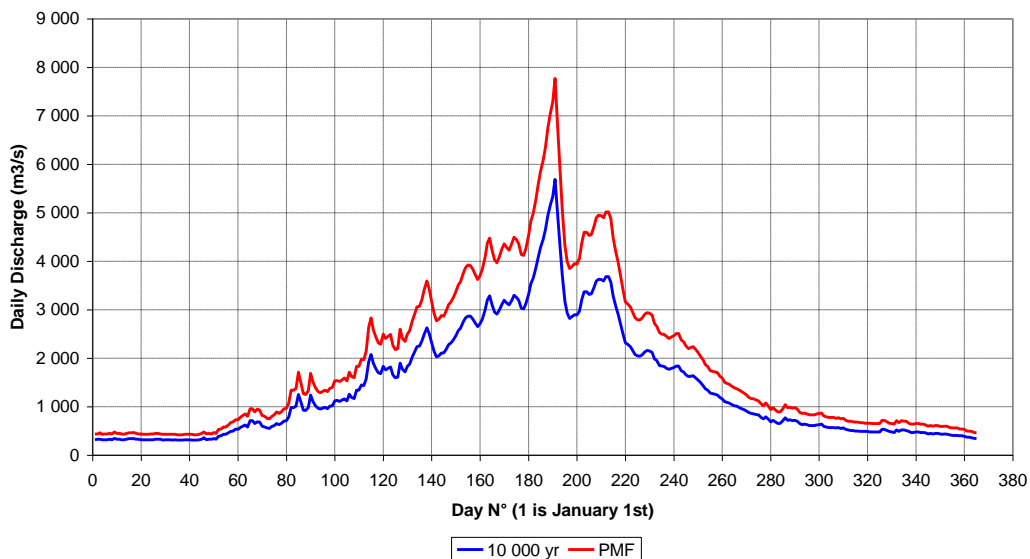

**Figure 9 : 10 000 yrs and PMF Flood Hydrographs**

## 5 CLIMATE CHANGE IMPACT

The Consultant tried to develop its own approach to the impacts of Climate Change based on a trend analysis of historical data as well as on available literature on Climate Change in Central Asia and Tajikistan. The study was conducted as follows: firstly, an analysis of the observed trends for the 1930-2010 periods was carried out for precipitation, discharge, and temperatures. The correlations found are not fully convincing, but a trend in increasing precipitation and discharges could be identified. For the Fedchenko Glacier, an increase of 0.5°C per 100 years is noticeable and is in the same order of magnitude as existing models.

Secondly, a review of the literature was conducted to gain a general understanding of the current status of Climate Change predictions in Central Asia and Tajikistan. Data enclosed in Aral Sea depletion studies indicate that, as per the projections, the glaciers feeding the Aral Sea could disappear by 2080-2100. Studies carried out by Tajik institutes clearly show that the glaciers are receding. It was therefore found of interest to carry out a specific analysis about the disappearance of glaciers and to try and evaluate its impact on the Vakhsh river regime. Following this specific study about glacier disappearance, the Consultant tried to assess the evolution of Vakhsh discharges under the assumption that there is a trend of increasing discharge (at the same level as the historical trend) associated with a reduction in the amount of glacial meltwater fed to the river because of increasing temperature, as suggested by the Climate Models.

The assessment of the potential impacts of climate change indicated that the most likely scenario is a gradual decrease in flood peak volumes because of earlier and longer melt seasons linked to increased temperature and glacier retreat. A change in the annual distribution of discharge could also lead to an increase in the value of the average annual discharge. This confirmed that the value of PMF chosen independently to this expected trend is conservative, as peaks could be expected to decrease in future.

Based on this preliminary assessment of the potential impact of Climate Change, some recommendations were given on how to ensure that the proposed Rogun Hydropower Project integrates adaptive measures to Climate Change at an early stage of its design. This will allow accounting for uncertainties and inconsistencies in the existing Climate Change prediction models available for Central Asia. The main purpose is to set up a monitoring system for early detection of changes in flood regimes and implement corrective measures accordingly.

## CHAPTER 2.6: SEDIMENTATION

### 1 INTRODUCTION

The proposed Rogun project is a large reservoir dam in a natural context where the annual sediment rates are recorded to be very high. Consequently the project is prone to be affected by sedimentation processes, the reservoir created being favorable to particle settling.

This therefore requires the viability of the proposed alternatives to be assessed taking into account the impact of sedimentation, in particular on the reservoir capacity and on operational constraints. It also raises the necessity to address the general concern about the long-term behavior of large reservoirs and identify an appropriate end-of-life strategy to be implemented to ensure long-term sustainability of the project.

The present chapter comprises a complete review of existing data on the characteristics and quantity of the solid particles transported by Vakhsh River, including an analysis of investigation campaigns carried out in the past at Nurek reservoir. This allows a reasonable estimate at this stage of the studies of the yearly solid runoff at Rogun.

The second part of the Chapter is a review of the state of the art sediment management options used worldwide and their applicability to the Rogun project.

The third part outlines a proposed sediment management plan for Rogun project during the operation phase, ensuring that all alternatives are designed for the longest possible economic life together with safe operation. Considerations are also given to an end-of-life strategy to ensure sustainability and safety of the Rogun project in the long run.



## 2 VAKHSH RIVER SEDIMENT CHARACTERISTICS

A comprehensive review of all existing information has been carried out under this assessment. This included gathering available raw data and results of tests carried out in the past. Assessment of existing grain size distribution curves, specific weight measurements, and concentration records led to an evaluation of the reliability of the basic sediment data available. Important scattering has been highlighted and the need for additional tests following international standards recommended for the next steps of the studies in particular for refining the suspended load concentration and grain size distribution.

## 3 NUREK RESERVOIR EXPERIENCE

### 3.1 Available information

One crucial source of information for an assessment of sedimentation in the Vakhsh River is Nurek Reservoir that catches sediment inflows from the River since its impounding in 1972. Several surveys have been carried out over the years to investigate the sedimentation pattern of Nurek reservoir: in 1989, 1994 and 2001.

	Volume (km <sup>3</sup> )			
	1972	1989	1994	2001
<b>Storage</b>				
<b>Total</b>	10.50	8.66	7.96	8.63
<b>Live</b>	4.50	3.40	3.06	4.27
<b>Dead</b>	6.00	5.26	4.90	4.36

**Table 9 : Evolution of Nurek reservoir capacity**

Even taking into account bank transformations, the increase of capacity reported between 1994 and 2001 is difficult to explain:

- in a specific report on Nurek reservoir, the erosion of banks is evaluated at 77 Mm<sup>3</sup> for the total period 1972-2001, ie 2.66 Mm<sup>3</sup>/year.
- Lahmeyer [2] make a reference to the report of the 1994 survey where it is stated that the volume of bank transformation is 21 Mm<sup>3</sup> between 1989 and 1994, ie 4.2 M<sup>3</sup>/year.

This discrepancy was also highlighted in previous studies.

**Therefore, the Consultant considered 1972-1989 campaigns as the most reliable sets of measurements, when Nurek reservoir was filled by 108 Mm<sup>3</sup>/ year.**

### **3.2 Further campaign in Nurek Reservoir**

For long term sustainable sediment management of the Rogun reservoir, a clear understanding is required not only of the annual sediment transport volume and the corresponding loss of storage but also of the configuration of the sediment deposition patterns over the life of the project. To obtain this kind of information, the Nurek reservoir sedimentation process since its impoundment in 1972 is an excellent source of information.

The following investigations are therefore required to be carried out in Nurek reservoir during the next phase of the studies:

- Bathymetric survey of the reservoir sedimentation using multi-beam echo sounding.
- Longitudinal and transversal cross sections of the sediment deposition in the reservoir.
- Bed samples of deposited sediments.
- Core samples along the topset and foreset slopes.
- Annual reservoir water level variations and corresponding river discharges.
- Measurement of suspended sediment concentration and particle size distribution at different depths along the reservoir for various river discharges.

## 4 YEARLY SOLID RUN OFF ESTIMATE

Various hydrometric methods used in HPI studies – such as direct measurements of suspended load and bed load in the Vakhsh river and study of wash away intensity from the catchment area – have led to estimating a total yearly solid run-off comprised between 87 and 125 Millions of tons. Considering a specific weight of sediments of  $1.4 \text{ tons/m}^3$ , this corresponds to a yearly solid run-off comprised between 62 and 89  $\text{Mm}^3$ .

Following a hydrovolumic method applied to the Nurek reservoir and based on the most reliable bathymetric surveys available, the estimated rate of sediment inflow in Nurek reservoir is approximately  $100 \text{ Mm}^3$  per year.

This lead to the conclusion that the total yearly solid run-off of the Vakhsh River ranges between 62 and 100 Million  $\text{m}^3$  per year.

This range of uncertainty cannot be narrowed at this stage of the studies. For the purpose of this study (in particular for determination of the economic life of the project), as a conservative approach, the value of  $100 \text{ Mm}^3$  / year is considered as a representative assumption of sediment solid run-off in Vakhsh River.

## 5 REVIEW OF AVAILABLE SEDIMENT MANAGEMENT SOLUTIONS

### 5.1 Inventory of possible measures:

To ensure project safety and sustainability, several possible measures to reduce the impact of sedimentation can be considered. The following possible mitigation measures and their applicability to the specific Rogun conditions have been reviewed in the course of the studies:

- watershed management
- upstream check structures
- reservoir bypass
- off-channel storage
- adequate operating rules
- tactical dredging
- flushing

## 5.2 Reducing sediment inflows

### 5.2.1 Watershed management

In the case of Rogun, the catchment area is very large and the soil is naturally poor and not suitable for afforestation or specific farming techniques (bundling, terracing...). Therefore such a method would have a very limited impact on the overall sediment inflows.

### 5.2.2 Upstream check structures

The upstream check structures option would consist in trapping or storing the sediment inflows on Vakhsh tributaries upstream of the Rogun reservoir. It requires emptying the trap from its sediment after each flood. In the case of Rogun, this solution cannot be applied given the amount of sediment to evacuate yearly.

### 5.2.3 Off-channel storage

The off-channel storage consists in diverting the river during high sediment transport period into specific reservoir outside of the river channel, in a small tributary for instance. In the case of Rogun, the topography is not suitable for such solution: because tributaries are steep slope valleys, the storage areas in their upper part are very small compared to the annual solid run off.

### 5.2.4 Reservoir bypass

This solution would consist in diverting the sediment flood around the reservoir: during high floods, the river would be diverted from the reservoir to a specific water way that reaches the main river downstream of the dam.

In the case of Rogun, the fairly straight shape of the reservoir makes this solution difficult to implement. Moreover discharging the sediment load in Nurek reservoir would only shift the problem to Nurek project. The technical problems associated with sediment scour and the high cost of such large and long tunnel suggest that a by-pass tunnel will not be feasible. Furthermore, the annual sediment load is not concentrated in a short period of time.

## 5.3 Managing sediment within the reservoir

### 5.3.1 Adequate operating rules

Reservoir sedimentation and the progression of the sediment delta towards the dam can be controlled to a certain extent by controlling the reservoir operating conditions (including modification of the level of the intakes during the life of the project to extend the generation phase).

According to the reservoir operation studies, the yearly reservoir drawdown is 30 m for the highest alternative (10% of the maximum reservoir depth), 50 m for the medium (17%) and 80 m for the lowest alternative (33%). The higher the alternative, the less sensitive to yearly drawdown it would be.

However for sustainable sediment management of such a large reservoir, it is in any case advisable to adjust the operating rule of the reservoir to the sedimentation pattern. This includes raising the level of the intakes while the sediment level at the foot of the dam is raising to extend the life of the generation system. The proposed sediment management plan during operation of the project is described in the next paragraph.

### 5.3.2 Tactical dredging

The tactical dredging consists in localized dredging of the most critical area: power intakes, spillways intakes. In the case of Rogun, such dredging can only be localized after several decades, when the sediment foreset gets close to the power intakes. However, given the annual load of sediments, tactical dredging might not bring significant effect on protecting the intakes against clogging.

## 5.4 Evacuation of sediments from the reservoir

### 5.4.1 Reservoir Flushing

Flushing consists in using a low level tunnel to remove sediment already deposited in the reservoir thanks to the flow velocity and transport it downstream of the dam.

Such a solution has been studied by the Consultant but later discarded as this solution was deemed not viable due to the fact that it would have to work under high head. Some other drawbacks were noted, linked also to the nature of the Obi-Shur creek, which is the only possible point of discharge for a tunnel starting from the power intakes area.

#### **5.4.2 Sluicing and density current venting**

Sluicing consists in discharging the loaded flow through the outlets before it settled in the reservoir.

Sluicing has been proved to be efficient in certain large dams all over the world. But, both the sediment type, and the dam type make it not applicable to Rogun. Large sluicing gates cannot be set at the bottom or at mid-level of Rogun reservoir to cross the dam as it is an embankment dam.

Density current venting consists in making use of the current created by the reservoir water density gradient to transport the sediment downstream of the dam, through specific tunnels or through the turbines. In the case of Rogun, turbidity current could be discharged through the turbines using the multi-level water intake presented in §5.7.4. However Additional tests will be necessary to fully understand the characteristics of the suspended material in turbidity currents. This will assist in assessing the merits of passing it through the power station versus the potentially negative impact on the electro-mechanical equipment.

It is to be highlighted that, given the large uncertainties on the parameters driving this phenomena (average yearly run off, amount of fine, density, amount of turbidity currents that will reach the intakes, impact on Nurek storage, etc.), the Consultant has not considered the release of turbidity currents through the turbines in determining the operational life of each alternative as used in the economic analysis of the project alternatives.

#### **5.4.3 Mechanical removal**

Sediment extraction by dredging, hydro-suction or dry excavation is performed on several reservoirs in the world. In Rogun, the volume of annual solid run off is too large for such a method. Therefore, mechanical removal is not a feasible solution in the case of the Rogun dam.

### **5.5 Replacing lost storage**

In the case of Rogun raising the dam is not a foreseen solution, as it already reaches the practical limitation, especially in terms of flood management, and energy dissipation. On the other hand, the construction of new dams could be foreseen, even though it does not solve the issue of sediment management but only shifts it upstream. The technical and economic feasibility of sites upstream of Rogun dam has still to be assessed and that is beyond the scope of this study. This option does not provide any long term solution to the sedimentation issue on the whole cascade as it only delays the problem of dams filled with sediments on the long run.

## 5.6 SEDIMENT MANAGEMENT PLAN FOR ROGUN PROJECT

### 5.7 Operation phase of the project

#### 5.7.1 *Storage depletion throughout the life of the project*

Based on a yearly solid run off of 100 hm<sup>3</sup>, the reservoir storage capacity curve can be calculated thanks to the method proposed by the US Bureau of Reclamation (1987). This simplified procedure does not take into account the variation of the trap efficiency and sediment deposit pattern over time. However this method is sufficient for the level of this study and with respect to the other uncertainties, especially on the yearly solid run off estimation.

This curve is presented in the Reservoir Operation Chapter (Volume 3, Chap 3.5).

#### 5.7.2 *Early generation*

As an early generation phase is planned during the construction period of the Rogun project, it will be necessary to adapt the water supply to the Units 5 & 6 for various reservoir levels.

The consequence of power generation using low reservoir water level when the storage volume is small is that the risk of sediment intrusion into the power discharge might be high.

Specific devices designed by HPI and retained by the Consultant in the proposed layouts aim at protecting the powerhouse from sediment entry during the early generation phase.

#### 5.7.3 *Impact on regulation capacity and energy generation*

In the case of the coupled operation of the Rogun and Nurek reservoirs, the following will progressively happen as sediments are trapped in the Rogun reservoir:

- Phase 1: As the active storage of Rogun decreases, the amplitude of the yearly oscillation of reservoir levels (necessary for the regulation of river discharges) increases to compensate the loss in storage capacity. Discharge regulation (increase of winter discharge) is not affected but head in late winter get reduced. Energy can be consequently slightly affected if the head loss is significant compared to the total head.
- Phase 2: When the lowering of reservoir level (necessary for discharge regulation) is too important, the optimum coupled operation of Rogun and Nurek is to be reviewed: the Nurek



reservoir starts its contribution to the flow regulation, getting its winter head reduced. Energy generation is consequently reduced.

Several simulations have been run to assess the energy production at various time steps assuming that the total sediment load is 100 Mm<sup>3</sup>/yr and that all sediments are trapped in Rogun (no allowance for turbidity currents as a conservative approach).

This is presented in the following graph:

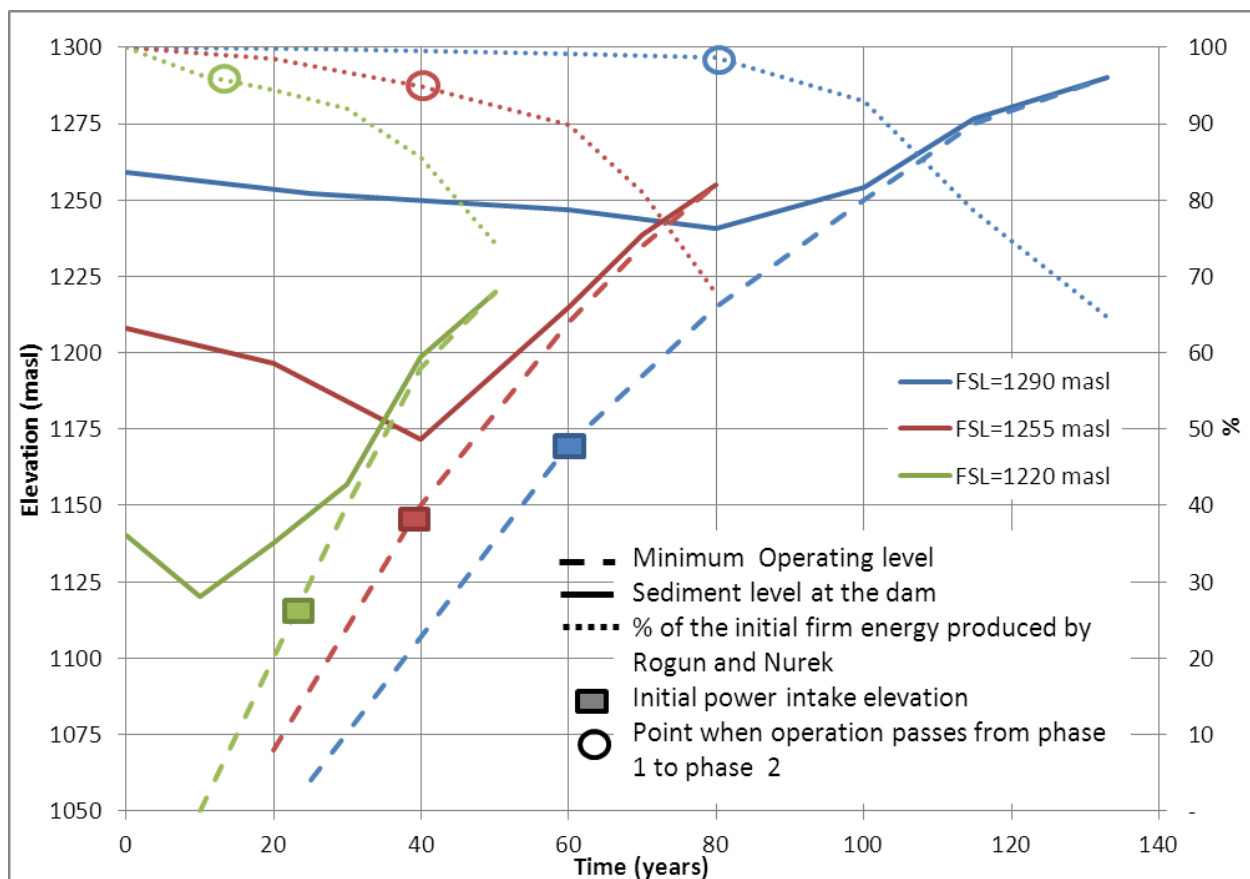

**Figure 10 : Evolution of optimum minimum reservoir level, firm energy and sediment level with time, for a sediment load of 100 Mm<sup>3</sup>/yr**

It can be seen that the energy production starts being reduced by about 5%:

- after 20 years for the lowest alternative;
- after 40 years for the medium alternative;
- after 90 years for the highest alternative.

Then during Phase 2 when the minimum operating level starts to rise again, the energy curve keep decreasing slowly, and a slope change happens when the new reservoir bottom reaches the minimum level. Then, the curve is sharper, and the energy decreases quickly.

#### **5.7.4 Power intakes raising**

In parallel to the depletion of storage capacity and the modification of the Rogun-Nurek coupled operation, another sediment management solution would be raising the power intakes.

Indeed as it can be seen on the previous graph, power intakes plugging will occur much before the regulation capacity depletion for the two highest alternatives. Without any special design or remedial measure, the energy production would be limited by the intake life span.

Therefore, the Consultant proposes a special intakes design that will lengthen the powerhouse lifespan. The power intake sill remains at the same elevation, but a concrete structure is anchored on the bank slope, and is equipped with several gates at several elevations. This will allow opening and closing the gates as the sediment rises, and adapt the power intake elevation as necessary.

Thanks to this device that actually allows to raise the intake level, the life span of the energy production is extended and adapted to the reservoir life span. In the last upper meter of the reservoir, the flow will not be naturally de-silted by the reservoir. Therefore it has been considered that this structure can be used until the sediment reaches the FSL minus a safety margin of 15 m. The following table presents the Rogun power production lifespan that have been considered in the economic and financial studies of the alternatives:

<b>Dam alternative (FSL)</b>	<b>1290</b>	<b>1255</b>	<b>1220</b>
Life span (years) (with 100 hm <sup>3</sup> /year)	115	75	45

**Table 10 : Power intake life span with raising intake**

#### **5.7.5 Impact on electro-mechanical equipment**

The Rogun electro-mechanical equipment will be impacted by the sediment load only after a long period of operation: the reservoir acts as a desilting device and the water passing through the turbines will be clear of sediment as long as the intake sill is not reached. This is experienced today in the Nurek reservoir.

When turbidity currents reach the special intake structure a decision will need to be made on whether to pass the suspended sediments through the turbines or exclude them by using a higher

level intake gate. Additional tests are required to fully understand the characteristics of the suspended material in turbidity currents. This will assist in assessing the merits of passing it through the power station versus the potentially negative impact on the electro-mechanical equipment.

When the coarse material will reach the upper position of the special intake: the equipment will be eroded by the coarse sediments and the powerhouse should be put out of operation.

In both cases, the long term sediment management shall then be put in place to ensure balance between inflows of sediments and outflows and ensure long term safety. This is detailed in the following paragraph.

## 5.8 Long term sediment management and sustainability:

### 5.8.1 End of life definition:

As already mentioned above, based in the estimated range of run off, the ultimate reservoir life span (when the powerhouse is put out of operation with a final intake level at FSL – 15 m) can be calculated for each alternative.

	Total volume (hm <sup>3</sup> )	100 Mm <sup>3</sup> /year
<b>FSL=1290 masl</b>	13 300	115 years
<b>FSL=1255 masl</b>	8 600	75 years
<b>FSL=1220 masl</b>	5 200	45 years

**Table 11 : Estimated Rogun reservoir ultimate life span**

### 5.8.2 End of life sediment management:

Rogun project under its initial design comprised tunnel spillways only with submerged intakes. The inherent risks in such type of design are cavitation caused by high water velocities and degradation caused by introduction of abrasive sediments.

The risks of cavitation due to high clear water velocity may be satisfactorily solved by means of an adequate hydraulic design and with the help of appropriate aeration. Therefore, submerged intakes

can be safely used in the first decades of the Rogun operation as long as clear water is discharged, if adequate aeration features have been designed.

However, at some point of time if abrasive materials enter the tunnel spillways, important damages would occur. Such risk will be unacceptable for Rogun project after decades when coarse sediments will be carried into spillways tunnels and could cause structural failure.

Moreover, as per the Consultant's flood management design, these tunnels spillways are meant to protect Rogun and the whole downstream cascade from the PMF thanks to the Rogun reservoir routing capacity. As the reservoir routing capacity will reduce with time, this protective function has been designed to be effective during a limited period.

Therefore, a free surface overflow spillway with adequate aeration and dissipation device would be a mandatory long-term solution in order to safely pass the design flood when spillway tunnels will be put out of operation by sedimentation.

The Consultant developed a design for such a surface spillway. The dissipation device is made of successive stilling basins that allow controlling the water velocity in the channel down to acceptable values.

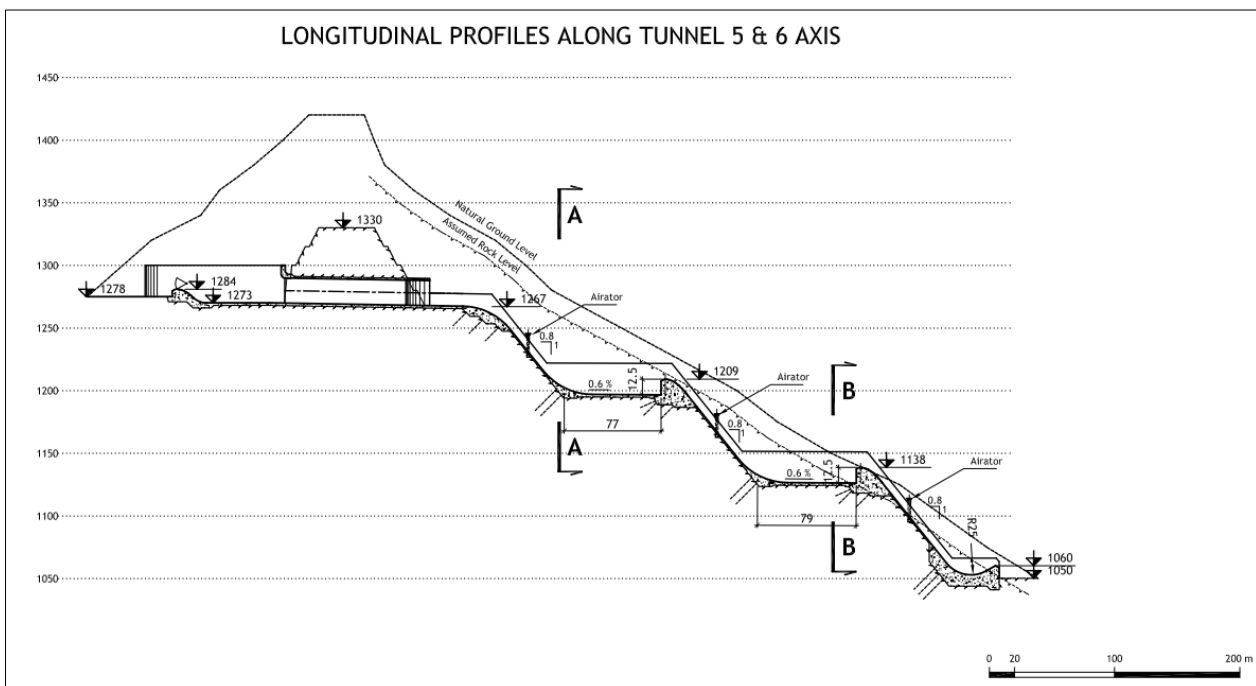

Figure 11 : Proposed surface spillway longitudinal profile

At the long term, this surface spillway could also discharge the solid inflows and manage the sediment balance, when the plant and the other spillway facilities will be put out of operation. This could be a solution to manage coarse sediment in the longer term and avoid extreme dam safety issues. It would require large operation and maintenance costs during the first years of operation with coarse material passing through every flood season.

An ultimate end of life closure option could be to remove the gates from the surface spillway allowing the sediments to carve an incised channel through the spillway and underlying rock over a period of several decades. This scenario envisages that the incising river would bypass the dam structure, which would be abandoned and slowly release the sediments downstream. Other options may be considered at a horizon of 100 years and more to cope with long term safety of the abandoned structure, but the surface spillway can be considered as a potential answer to avoid extreme safety scenarios in the event that no other re-engineering solution is found in the long term future for the Rogun project.

## 5.9 Vakhsh cascade

Presently, the sediment load of the Vakhsh River is trapped into the Nurek reservoir. In the future, if Rogun is not constructed, Nurek will be progressively filled with sediment. At mid-term some structures will be impacted (power intake, bottom spillway for instance) and at long term the project safety will be questioned.

At that time, the Vakhsh River will not have any regulation capacity which would largely decrease the energy produced in winter.

Flood evacuation at Nurek will also be an issue as Nurek spillway system consists mainly of tunnel spillways that, as explained above, cannot handle sediment-loaded water. The total discharge capacity of Nurek will in that case be much lower than the PMF value.

Construction of Rogun will largely decrease the Nurek reservoir sediment filling rate, ensuring the river regulation for a significant additional time period of time, and delay the need of rehabilitation of the flood evacuation system with respect to the sedimentation issue.

This is an important feature of Rogun project with respect to the overall sustainability of the Vakhsh cascade.

## 6 CONCLUSIONS AND RECOMMENDATIONS:

The solid run-off of the Vakhsh River has been estimated to be about 100 Mm<sup>3</sup> per year (this value corresponds to a probable upper limit). The evaluation of Vakhsh solid run off should be completed by using state of the art sediment sampling and by carrying out a detailed sediment study in the Nurek reservoir prior to the detailed design phase.

Depending on the alternatives the ultimate life span of the whole reservoir is in the range of 45 years for the lowest alternative, 75 for the medium and 115 years for the highest alternatives.

Man will not be able to control the sediment transportation of the Vakhsh River, at best it can delay and/or limit its impact on the proposed Rogun project and propose an end of the life solution, ensuring sediment balance when the dam will be abandoned.

At this stage of the study and given the data available, some general recommendations in terms of design and operation can be made:

- A complete surface spillway is necessary as a long-term measure to safely pass the floods and their solid load.
- Reservoir operation of both Rogun and Nurek will be adapted as the sediment deposits in the Rogun reservoir.
- A multi-level power intake should be constructed to lengthen the powerhouse and reservoir life span.

In the long term, the reservoir will be completely filled with sediments and the annual solid load will be discharged through the surface spillway. There will be important maintenance works each year to repair the damages caused by the sediment transportation in the spillway channel, but the dam safety will be ensured. After several decades of this situation an end of life closure scenario could be envisaged, involving the proposed surface spillway as a river bypass structure.

Further studies and physical hydraulic modelling would be required to design a complete sediment management plan that should be making use of Nurek experience. Therefore, the following is recommended:

- Thorough analysis of Nurek sedimentation thanks to new surveys including echo sounding bathymetry, core sampling, measurement of suspended sediment concentration and particle size distribution;

- Detailed simulation of the Nurek and Rogun sedimentation pattern, including behaviour of possible turbidity currents;
- Analysis of the possible impact on the permanent equipment resulting from passing turbidity currents through the multi-level intakes; whenever the studies indicate unacceptable adverse impact, the multi-level intakes would be used only to continue operating the plant while sediments will be already higher than headrace tunnels inlets;
- Optimization of sediment management for the whole cascade..



## **VOLUME 3: ENGINEERING AND DESIGN**

## CHAPTER 3.1: DESIGN CRITERIA

### 1 INTRODUCTION

The present design criteria will be used for Phase 0, I and II of the project. These criteria can be applied to any component of the Rogun project designed for a long-term operation. The design criteria apply to any part of the existing works. It means that, if necessary, affected existing works must be adjusted to meet the design criteria.

### 2 BASIC DATA

ITEM		DESCRIPTION	Ref.
Dam risk classification		<ul style="list-style-type: none"> <li>- Define the risk class.</li> <li>- Determine the choice of design flood and design earthquake.</li> </ul>	ICOLD Bulletin 148 and 82
Design Flood	General	Determine the appropriate discharge capacity of the project.	
	10,000 years flood	Based on regional approach.	
	Probable Maximum Flood (PMF)	<p style="text-align: center;"><u>PMF Derivation</u></p> <ul style="list-style-type: none"> <li>- Data: Discharge, Rainfall, Temperature.</li> <li>- First stage: Daily discharge versus temperature.</li> <li>- Second stage: Daily discharge versus degree-day factor.</li> <li>- Third stage: Maximizing the obtained results.</li> <li>- Climate change (increasing temperature).</li> <li>- GLOFs (additional freeboard).</li> <li>- Landslides being triggered by reservoir impoundment.</li> </ul>	PMP derivation 1986
	Construction flood	<ul style="list-style-type: none"> <li>- Return period of construction based on a probabilistic approach (no more than 1/1000).</li> <li>- Criteria: Reservoir level &lt; (Dam elevation – Dry freeboard)</li> <li>- Criteria for tunnel operation: head limited to 120 m in normal conditions or existing structures and 150 m in extreme conditions for new tunnels</li> <li>- Sufficient redundancy in the system</li> </ul>	
Geological / Technical data		The design will use existing data from previous investigations and from the supplementary investigations undertaken in 2012 - 2013.	

ITEM	DESCRIPTION	Ref.
Seismic design parameters	Two levels of earthquakes are considered: <ul style="list-style-type: none"> <li>- MCE (Maximum Credible Earthquake)</li> <li>- OBE ( Operating basis Earthquake)</li> </ul>	ICOLD Bulletin 148
Sedimentation	No recent measurement	HPI 2009

### 3 DESIGN CRITERIA

ITEM	DESCRIPTION	Ref.	
<b>Dam</b>	Freeboards	Take into account GLOF, Slope instabilities and permanent settlements	USBR
	Intermediate construction stages	Appropriate spillway to handle the design flood at any stage.	
	Embankment	<p style="text-align: center;"><u>Stability</u></p> <ul style="list-style-type: none"> <li>- Stability checked with a two-dimensional analysis</li> <li>- Minimum safety factor varying between 1.2 and 1.5</li> <li>- A three-dimensional analysis will be performed in next Phase of the studies</li> </ul> <p style="text-align: center;"><u>Seepage</u></p> <ul style="list-style-type: none"> <li>- Particular attention must be paid to the salt dome and dam/cofferdam foundation and abutments</li> <li>- A grout curtain must be developed.</li> </ul> <p style="text-align: center;"><u>Settlement</u></p> <p>Long-term settlement of the dam embankment and its foundation to ensure freeboards are retained.</p>	USBR, n°13 – Chap 4
	Filters and transition	<ul style="list-style-type: none"> <li>- Filter criteria regarding percentage of finer, for silts, sands, clays, clayey and gravels.</li> <li>- Criterion to prevent segregation: Minimum D10 and Maximum D90.</li> <li>- Kenney and Lau method/Terzaghi criterion: to check whether the base soil is internally stable.</li> </ul>	USBR, 1994. ICOLD, bulletin 95
	Regional seismicity	<ul style="list-style-type: none"> <li>- Recommendations on the foundation, reinforced concrete, transverse foundation slope across the core zone, foundation/core contact, normal filter and drain zones, upstream and downstream transition zones, freeboard, ... A deterministic Seismic Hazard Assessment will be carried out at this stage of the studies.</li> </ul>	ICOLD bulletin 120

ITEM		DESCRIPTION	Ref.
	Fault crossing	<p style="text-align: center;"><u>Embankment</u></p> <ul style="list-style-type: none"> <li>- The dam design should accommodate a foundation fault creep and displacement. Within a distance of 50 m of the active fault, the thickness of any layer in the direction of the movement of the active fault should amount to at least 1.5 times the fault displacement.</li> </ul> <p style="text-align: center;"><u>Tunnels</u></p> <ul style="list-style-type: none"> <li>- Long-term fault movement must not influence the hydraulic operation of tunnels.</li> <li>- Minimize crossing of active fault (especially for pressure stretches).</li> <li>- Maintenance intervention anticipated.</li> </ul>	
	Salt Wedge	<ul style="list-style-type: none"> <li>- A monitoring system must be installed.</li> <li>- A contingency plan must be defined.</li> </ul>	
<b>Hydraulic Works</b>	Power waterways	<ul style="list-style-type: none"> <li>- Adoption of one independent waterway for each generating unit.</li> <li>- Dimension of tunnels based on the concept of the economic diameter.</li> </ul>	
	Spillways	<ul style="list-style-type: none"> <li>- Maximum reservoir level compared with the crest elevation considering maximum settlement.</li> <li>- 10,000 years flood: N-1 orifice or n-1 gates →MWL&lt; top of the dam core</li> <li>- PMF: N orifice or n gates →MWL&lt; top of the dam core</li> <li>- Concrete surface treatment to prevent cavitation (due to high speed flow), and erosion (due to sediment flow).</li> </ul>	
	Others structures	<p>Specific design criteria for:</p> <ul style="list-style-type: none"> <li>- Inlets, Intakes and water entrances, Entrances and Upstream Ends of Piers, Downstream Ends of Piers, Bends, Divergent Transitions, Guide Recesses and Slots, Joints in Conduits, Overflow Profiles</li> <li>- Specific care for slope stability above the intakes</li> <li>- Long term safety of the flood handling system, necessity of a surface spillway once tunnels will be put out of operations due to sediment accumulation in the reservoir</li> </ul>	
<b>Underground works</b>	Phase I	<p>During this phase of the Project, the available design of the Works already executed will be reviewed to assess whether they are appropriate for the project. This includes the existing design of all tunneling, shafts, chambers and caverns like the powerhouse and transformers hall.</p> <p>The tunnels are to be designed (recommended strengthening measures or new linings) so to make the structures capable to resist:</p> <ul style="list-style-type: none"> <li>• Loads due to rock-lining interaction.</li> <li>• Seismic loads;</li> <li>• Water pressure, not less than 200 kPa for all stretches upstream from fault 35 and 100 kPa for stretches downstream from the same.</li> </ul> <p>Detailed calculations have to be carried out to define the details of the scheme of interventions, which may have to be adapted to the local conditions, on account of rock mass characteristics and structure location.</p>	

ITEM		DESCRIPTION	Ref.
	Phase II	<p>During this phase, simple empirical design criteria may be adopted based on:</p> <ul style="list-style-type: none"> <li>- A rough estimate of the rock mass characteristics (RMR);</li> <li>- The pre-dimensioning of the temporary supports based on the Barton classification, where appropriate;</li> <li>- The pre-dimensioning of the lining thickness as a function of the RMR. The lining thickness may range from 1/9 to 1/12 of the diameter for the tunnels and shafts.</li> </ul>	
	Earthquake	<p>The seismic effects on the Caverns and Tunnels stability shall be estimated by taking into account:</p> <ul style="list-style-type: none"> <li>- The static and dynamic geo-technical properties of the rock masses.</li> <li>- A selection of the constitutive law parameters of the various materials of the rock masses.</li> </ul>	
<b>Scheme operating criteria</b>	Dam operating	<p>The Rogun dam Project will be designed to handle the PMF flood. Modeling of the operational discharge regime of Rogun will be a part of the Cascade Operations Model, including reservoir flood routing.</p> <p>If possible, Rogun will be designed for PMF routing in order to limit the discharge downstream of Rogun to the flood evacuation capacity of Nurek project.</p> <p>For the operational phase of the Rogun project, it is the Government's intent to limit the transfer of water from the vegetative season inflows at Rogun to the non-vegetative season releases downstream of Nurek to 4.2 BCM, which is the quantity currently transferred by the operation of the Nurek reservoir utilizing its present full storage capacity. This operating regime will not change the downstream flow pattern.</p>	
	Rate of filling and emptying	<p>It will be controlled in such a way that:</p> <ul style="list-style-type: none"> <li>- The triggered seismicity recorded at Nurek can be minimized during Rogun operation.</li> <li>- The hazards of landslides in the banks of the reservoir can be minimized.</li> <li>- Downstream water demand requirements: The Government's intent is to fill the Rogun reservoir using part of the share allocated to Tajikistan under current agreements and practices.</li> </ul>	
	Downstream water dam	<p>Studies should be carried out for the need and feasibility of facilities to enable safe drawdown of the reservoir in case of an emergency. The drawdown rates should ensure that the safety of the dam is maintained.</p>	
	Energy production	<p>The studies of reservoir operation will aim at optimizing the energy output consistent with the downstream water demand.</p> <p>Options to allow early generation during the construction period will be studied.</p>	
<b>Sediment management</b>		<p>Mitigation measures to address the long-term sediment impacts shall be considered to demonstrate that dam safety can be assured in the very long term. For instance, a reservoir maintained at a high level:</p> <ul style="list-style-type: none"> <li>- Leads to a reduction of live storage, but</li> <li>- Holds sediments away from the power plant intakes for longer.</li> </ul> <p>Attention must be paid to the liquefaction potential of the sediment deposits, in case of an earthquake.</p>	

ITEM	DESCRIPTION	Ref.
<b>Downstream disturbed zone</b>	Mitigation measures to be designed for the disturbed zone identified in the right bank – immediately downstream of the dam and opposite the Obishur Valley. This includes drainage systems, slope stabilization measures.	

## CHAPTER 3.2: SELECTION OF PROJECT SITE, POWERHOUSE LOCATION, DAM TYPE AND ALTERNATIVES TO BE STUDIED

### 1 INTRODUCTION

The studies on the Rogun HPP project were initiated in 1963, completed in 1978, and revised in 1981, when Nurek was put into operation. In the initial project, the reservoir full supply level (FSL) was 1,290 meters above sea level (m a.s.l.), and the dam was 335 m high. In 2009, the Rogun HPP Company appointed the Hydroproject Institute of Moscow (HPI) to study the completion of Rogun HPP. In 2011, Barki Tojik appointed the Consortium composed Coyne et Bellier/Electroconsult/IPA to assess the Project as currently laid down in existing studies. This report is an overall review of the existing information leading to the definition of the alternatives proposed to be studied under the present assessment.

### 2 KEY FEATURES OF HPI 2009-2010 PROJECT

#### 2.1.1 Dam, Reservoir and Powerhouse

- A zoned fill embankment 335 m high above foundation level, with 3,600 MW of installed capacity.
- An initial reservoir capacity at Full Supply Level (FSL – 1,290 masl) of around 13,300 hm<sup>3</sup>.
- A total volume of fill amounting to 71.4 Mm<sup>3</sup>, 7.2 Mm<sup>3</sup> of which represent the impervious central core.
- An underground powerhouse set within the left bank comprising six identical generating sets of 600 MW, housed in a cavern 70 m high, 21 m wide and 220 m long.

#### 2.1.2 Spillways at Completion

##### 2.1.2.1 Original Design in 2009

- In the 2009 design of Hydroproject Institute (HPI), the facilities for discharging floods during the construction of the stage 1 dam up to el. 1,060 m a.s.l. are made of two Diversion/Tailrace tunnels with an evacuation capacity of 3,290 m<sup>3</sup>/s at el. 1,033 m a.s.l. (“construction & operation tunnels of the 1st and 2nd level).



- The first discharge tunnel in the right bank (called “3rd level diversion tunnel”) was originally foreseen at elevation 1,060.0 m a.s.l.
- In a second stage, a tunnel (“diversion and operation 3rd level tunnel”) was foreseen in the right bank at a higher elevation, with an intake at 1,165.0 m a.s.l.
- Further to this outlets system, an additional spillways system was foreseen, constituted of a spillway tunnel with an intake at el. 1,145.0 m a.s.l., and a vertical shaft spillway.

#### 2.1.2.2 *Changes in the 2010 design*

The main changes in the 2010 design are:

- The previous 3rd level diversion tunnel was changed to a tunnel fully independent from the other ones, with an inlet at el.1,035.0 m a.s.l.
- The diversion and operation 3rd level tunnel, originally located at el. 1,165 m a.s.l., was lowered to el. 1,145 m a.s.l.

#### 2.1.3 **Early Generation**

Since the Rogun studies began in the 1970s, a staged construction has been planned in order to generate energy before the dam completion. A smaller dam embedded in the main one allows raising the reservoir level before dam completion. This is the Stage 1 dam, which has a crest elevation of 1110 masl. A temporary power intake and two temporary units have also been designed to make this early generation possible.

#### 2.1.4 **Existing Structures**

Presently, several structures have already been built, or partly constructed (Permanent structures, Stage 1 Configuration Structures, Temporary structures). The Phase I report details these structures as well as their present state.

The underground works performed at Rogun project sum up a total length of about 28 km and can be subdivided into different groups according to their role in the project’s implementation and their specific function:

- Permanent structures

- Stage 1 configuration structures
- Temporary structures

Assessment of the present conditions of all existing works and need for maintenance or strengthening works was provided in Phase I report of the present assessment.

### **3 SELECTION OF THE DAM SITE, TYPE AND AXIS**

#### **3.1 Dam Site**

The dam site has been selected by the Russian Engineers and has not been reconsidered since 1981. The Consultant has not found any documents justifying this choice, but understood the reasons to be that:

- The particular topography shows a very narrow valley compared to the rest of the river that allows constructing a high dam with a rather limited quantity of material.
- Upstream of the Rogun site, the Ionakhsh Fault runs along the river on the same axis. Therefore, the dam core would have been set across from an active fault which is not acceptable.

The Consultant's view is that the site is appropriate for the proposed dam.

#### **3.2 Comparison of dam alternatives**

##### **3.2.1 General**

In brief, without any other considerations on hydrology or geology, the technical aspects of design and construction of very high arch dams or rockfill dams with a central "impervious" core are fully mastered.

Regarding the RCC gravity dam and Concrete Face Rockfill dam, there is no reference to the existence of such dams that would be higher than 200 m. Clearly, it would not be reasonable to envisage an RCC arch or even an arch-gravity dam alternative for such high dams. On the contrary, again without considerations to hydrology or geology, there is no reason to reject

combinations of RCC blocks, no higher than 150 m, with a rockfill dam with a central “impervious” core.

### **3.2.2 Sensitivity to Seismic Events**

If well designed and well-constructed, the dam body’s sensitivity to seismic events is moderate whatever the dam type. In fact, it is rare that significant damages in dams occur when submitted to earthquakes. A reasonable conclusion is that, amongst all alternatives envisaged, there is some doubt about the CFRD. In addition, the full emptying of the reservoir would be necessary to repair the concrete slab, and this would be extremely problematic, as refilling the reservoir would take 10 to 15 years.

### **3.2.3 Possible Mitigation Measures**

Three main faults may concern the various types of dam: the Ionakhsh Fault, Fault 35, and Fault 70. Any concrete structure being the component ensuring watertightness to the dam should be avoided in this area; there is a high risk of fissures or even fractures occurring, due to movements of the faults. From this point of view, the CFRD, RCC gravity and arch dam solutions appear very risky. Conversely, the rockfill dam with impervious core may accept movements of faults. However, it is impossible to block even locally the movement of active faults; therefore these movements have to be accommodated by the dam body.

### **3.2.4 Risk Related to Salt Dissolution in the Ionakhsh Fault**

The risk related to salt dissolution in the Ionakhsh fault, as well as the corresponding mitigation measures are detailed in the Phase 0 report. The most sensitive dam from this risk perspective is the Concrete Face Rockfill Dam. The proposed mitigation technique combines a hydraulic curtain and grouting of the wedge cap. With adequate design, monitoring and maintenance, this risk could be greatly mitigated.

### **3.2.5 Sensitivity to Argillites / Siltstones / Mudstones**

The argillite/siltstone/mudstone (designated as siltstone in this section) is present in several formations found in the foundation of the dam. According to investigations, the long-term modulus of this material is lower than 4 GPa. However, a high concrete gravity dam needs a foundation of high elasticity modulus in the long term. The level of stresses exerted by rockfill dams (either with a central impervious core or with a concrete face) on the foundation is lower. If the long-term settlements resulting from the calculations are too high, the solution would be to deepen the foundation of the dam.

### **3.2.6 Sensitivity to Differential Settlements**

Such high dam may be submitted to significant differential settlements, due to the lower deformability of sandstone compared to siltstone. As the stratification is subvertical, there are few mitigation measures – deepening the foundation of the dam may help reducing the differential settlements to acceptable values.

### **3.2.7 Sensitivity to Flood Underestimate or Inefficient Spillway**

A flood underestimate or an inefficient spillway will lead to an overtopping of the dam (and a possible dam break). This risk can be removed by using rather conservative design criteria and an extremely careful assessment of the flood. In particular, the use of the Probable Maximum Flood is compulsory for this project.

## **3.3 Other Factors Considered for the Comparison of Dam Alternatives**

### Construction in Stages

For the 2009 Rogun project, two stages were mentioned – a first stage with dam crest elevation 1,110 masl.), and a second stage with dam crest elevation 1,300 masl.

The table below presents for each alternative:

- First, the possibility of construction in stages,
- Then the possibility of regular reservoir rising within each stage.

Dam alternative	Possibility of construction in stages	Possibility of regular reservoir rising for each stage
Impervious core rockfill	Easy	Yes
Concrete or RCC Arch	Difficult or impossible	Difficult or impossible
Gravity RCC	Yes	Yes
Concrete Face Rockfill	Yes	No
RCC Arch Gravity	Yes	Difficult or impossible
Rockfill dam with earth core dam with upstream concrete block cutting the heel	Yes	Yes
Rockfill dam with earth core dam with downstream concrete block cutting the toe	Yes	Yes

**Table 12 : Possibility of Stages in the Construction of the Dam**

### 3.3.1 Construction Schedule

According to the study carried out by HPI, the total duration of the Rogun dam construction for FSL 1290 is around 14 years. The total volume of the dam being 70 hm<sup>3</sup>, the average placement rate, all materials included, is around 420,000 m<sup>3</sup>/month.

The total duration of construction is close to 14 years for all alternatives (HPI design, CFRD dam, RCC dam, Arch dam). Nevertheless, an obvious advantage of the embankment dams is that several construction tunnels have already been excavated and a significant part of the preparatory works are completed.

### 3.3.2 Other Components of the Rogun Project

Several components of the project do not depend on the type of dam. These include the diversion system, powerhouse, and transformer cavern. Indeed, a significant quantum of work has already been implemented, and these components should be used to the maximum extent possible.

### 3.4 Selection of a Dam Type

A synthesis of the elements of comparison of the various types of dams considered, as detailed above, is given in **Table 13**.

Dam type	References of dams higher than 200 m	Sensitivity to movements along faults	Risk related to salt fill of Ionakhsh fault	Sensitivity to rock quality	Sensitivity to overtopping	Regular reservoir rising during construction
Clay Core Rockfill dam	Green	Green	Orange	Green	Orange	Green
Concrete Arch dam	Green	Red	Green	Orange	Yellow	Red
Gravity RCC dam	Orange	Red	Green	Yellow	Yellow	Green
Concrete Face Rockfill dam	Orange	Red	Orange	Green	Orange	Red
RCC Arch Gravity or Arch dam	Red	Red	Green	Orange	Green	Red
Rockfill dam with earth core dam with upstream concrete block cutting the heel	Green	Red	Orange	Yellow	Orange	Green
Rockfill dam with earth core dam with downstream concrete block cutting the toe	Green	Yellow	Orange	Green	Orange	Green

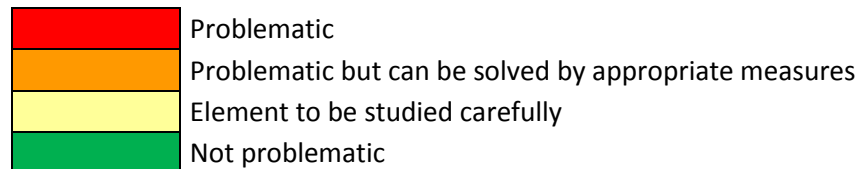

**Table 13: Comparison of Dam Types – Synthesis**

To conclude, the rockfill dam with central impervious core solution, which is proposed and designed for the Rogun project, is the most adequate type of dam. The design criteria for this dam should be adapted to the particular conditions of this site, namely active faults, the presence of salt in the Ionakhsh fault, a high seismicity, and risks of GLOF and of reservoir bank instabilities.

### 3.5 Location of Dam Axis

Due to the topographic conditions, there is little opportunity to significantly move the axis of a rockfill dam with a central impervious core. Therefore, only very limited adjustments to the location of the dam axis could be envisaged in the next stages of the project.

## 4 SELECTION OF POWERHOUSE SITE AND TYPE

The powerhouse cavern has already been partly built, as well as several facilities strictly linked with it.

During the inspections carried out by the Consultant, certain problems were noted, which required interpretation and analysis in view of assessing the suitability of the structure to be incorporated into the project.

The conclusions drawn from the modeling work performed by the Consultant confirm that the present status of the cavern excavation is critical and that under the design provisions previously proposed, its stability cannot be achieved. Therefore, a different set of stabilization measures has been proposed by the Consultant, which includes active anchors and dowels, as well as the adoption of Multiple Packer Sleeved Pipes (MPSP) that will reinforce the de-stressed rock mass of the “pillar area” between the two caverns, and can also be used to perform consolidation grouting. Possible alternatives to the proposed set of stabilization measures can be investigated and evaluated in detail at a later design stage.

While assessing the existing works stability, consideration was given to possible alternative solutions to the powerhouse present location.

In any case, in consideration of the present progress of the works, the existing solution is deemed the most convenient for the implementation schedule and from an economic point of view.

## 5 SELECTION OF THE ALTERNATIVES TO STUDY

The Consultant studied three full supply level alternatives which are summarized in the next table:

Full Supply Level (FSL)	Rationale
El. 1290 masl	<p>This is the maximum FSL foreseen in the 1978 design. It is not considered recommendable to exceed this height on safety and environmental grounds.</p> <p>This configuration is going to operate in a full sediment trapping mode, with an expected life of 150 to 200 years because no sediment management strategies are expected to be feasible due to dam height.</p> <p>Dam modification/ decommissioning in the long terms should be factored in the economic analysis.</p>
El. 1255 masl	Intermediate elevation. Sediment management feasibility to be assessed.
El. 1220 masl	This is the minimum level for a storage project with an expected reservoir life of at least 50 years. Any configuration with a FSL level below 1220 is expected to be a run of river scheme like Stage 1. Sediment management strategies, aimed at project sustainability, may be possible at this elevation.

**Table 14: Full supply level alternatives to study and corresponding rationale**

Additionally, three installed capacity per full supply level have been studied, which makes a total of nine alternatives studied. These alternatives are summarized in the table below.

	FSL = 1220 masl	FSL = 1255 masl	FSL = 1290 masl
<b>High installed capacity</b>	2 800 MW	3 200 MW	3 600 MW
<b>Medium installed capacity</b>	2 400 MW	2 800 MW	3 200 MW
<b>Low installed capacity</b>	2 000 MW	2 400 MW	2 800 MW

**Table 15: Installed capacities selected**



## 6 CONCLUSIONS AND RECOMMENDATIONS

The Consultant has considered:

- The same dam site and axis as HPI 2009,
- For the dam type, a rockfill dam with a central impervious core,
- The existing powerhouse, which can meet the required safety conditions and fulfill its initial purpose,
- Three installed capacities for each of three FSL alternatives have been studied by the Consultant.

Consequently, the assessment and selection of the best alternative is based on a range of nine alternatives (three dam heights, and three installed capacities for each of them).

## CHAPTER 3.3: ALTERNATIVE DESIGNS

### 1 INTRODUCTION

This chapter summarises the description and justification of the design proposed for the nine Rogun project alternatives by the Consultant, based on the assessment of the HPI 2009 Rogun project.

Several annexes are appended to this chapter to elaborate in details the design approach followed by TEAS Consultant in its own selection of alternatives:

- Appendix 1: Construction Material Assessment
- Appendix 2: Report on Embankment Dam Stability
- Appendix 3: Flood Management during Construction
- Appendix 4: Hydraulics of Project Components
- Appendix 5: PMF Management
- Appendix 6: Note on Freeboards due to Waves

### 2 SITE-SPECIFIC FEATURES

#### 2.1 Location within Regional Geological Frame

The Rogun dam site is located in the central mountainous region of Tajikistan, where the dominant trends are high mountain ranges and intense folding of the sedimentary series under high tectonic stresses. The area is tectonically active, with major active faults in close proximity to the site (the regional Gissar-Kokshal and Illiak-Vakhsh faults, then the comparatively minor Ionakhsh and Gulizindan faults).

#### 2.2 Nature of Rocks of Dam Foundation

With regard to the nature of the rocks of the foundation, the sedimentary series of the dam site are essentially made of an alternation of less resistant claystones and siltstones, against more

resistant sandstones, with diversely represented gypsum. Younger formations, such as Upper Cretaceous and Paleogene, additionally present strata of limestone, shales or chalk.

## 2.3 Salt Rock of Ionakhsh Fault

Salt rock pertaining to the Jurassic Gaurdak Formation is present along the two main thrust faults (Ionakhsh and Gulizindan), as well as diapirs along the Illiak-Vakhsh Fault, upstream of the dam site.

## 2.4 Geomorphological Features of Dam Site

### 2.4.1 General Aspect

The gorge at the dam site is V-shaped, with steep flanks of inclination from 40 to 60 degrees with locally steep cliffs along the river stream, especially in the sandstones formations.

### 2.4.2 “Disturbed Zone” of Right Bank

The right bank of the Vakhsh River is characterized by a peculiar morphologic feature.

It is however important to mention the presence of large and potentially unstable masses in the front part of this structure, at the foot of which large amounts of debris produced by the scouring of the slope accumulate. The riverbed of the Vakhsh River was moved off the right bank by 70 to 90 m between 1978 and 2005 for this reason.

## 3 DAM

### 3.1 HPI Dam Design

#### 3.1.1 Description

##### 3.1.1.1 Design

The ROGUN dam as designed by HPI (2009) is described in Table 16.

Item	Description
Dam height	335 m
Volume	71.7 Mm <sup>3</sup>
Volume of impervious central core	7.2 Mm <sup>3</sup>
Excavation volume	4.6 Mm <sup>3</sup>
Crest elevation	1300 masl
Full supply level	1290 masl
Downstream face slope	2H/1V
Upstream face slope (under 1140 masl)	2H/1V
Upstream face slope (above 1140 masl)	2.4H/1V
Thickness of Impervious core	140 m to 8 m
Filters	Fine and coarse, on both faces of the core
Grout curtain depth	100 m
Stage 1 downstream slope	1.7H:1V

**Table 16: Dam - Key data of HPI design 2009**

### 3.1.1.2 Dam Stability Calculation

Appendix 1 presents a full analysis of dam stability. The first paragraph presents the HPI documents made available to the Consultant on that topic and their assessment. The essential elements are summarized here.

The documents available contain: slope stability of the dam, 2D static and dynamic finite element model calculation, and 3D static and dynamic finite element model calculation.

### 3.1.1.3 Dam Material

The quantities defined by HPI, 2010 are detailed in the table below:

Dam part	Characteristic size	Quantity
<i>[-]</i>	<i>[mm]</i>	<i>[m<sup>3</sup>]</i>
Core	-	7 247 000
1 <sup>st</sup> transition layer	0 – 10	4 893 000
2 <sup>nd</sup> transition layer	0 – 40	
Upstream lower transition	0 – 80	
Alluvium shoulder	≤700	39 567 000
Rock shell	≤700	17 753 000
Rip rap	300 – 1000	1 497 000
Concrete slab	-	481 000
<b>TOTAL</b>		<b>71 438 000</b>

**Table 17: Materials quantities. HPI, Design 2010**

#### 3.1.1.4 Foundation Treatment

The foundation treatment foreseen by HPI is described below for each of the construction phase: pre-cofferdam, cofferdam, stage 1 and main dam.

Construction Phase	Foundation treatment
Pre-coffer dam	No specific foundation treatment.
Cofferdam	Bank instabilities and over hanging rock removed.
Stage 1 dam	Membrane foreseen by HPI is anchored in a concrete slab.
Main dam	Riverbed alluviums removed, as well as poor rock layer (zone 1) and replaced by concrete.

**Table 18: Foundation treatment, HPI**

### **3.1.2 Comments**

#### *3.1.2.1 Design*

As a general comment, the design incorporates all safety measures appropriate for such a high dam.

However it should be noted that:

- The Consultant found no information or drawing on the excavation foreseen for the core foundation.
- Two inspection galleries cross the impervious core from bank to bank and extend into the dam foundation are designed at el. 1,120 & 1,240.
- The Stage 1 watertight membrane is not acceptable.
- No information was given to the Consultant about the monitoring system foreseen by HPI.

#### *3.1.2.2 Dam Stability Calculation*

Overall, there is insufficient information to perform a real assessment of the available stability studies.

However, it can be noted that the permanent dam displacements found in the 2D finite element analysis are very small (below 1 m), which appears on the low side given the size of the structure and the intensity of the earthquake.

#### *3.1.2.3 Dam Material*

The following table summarizes the corrective processes to be implemented in order to ensure that these materials satisfy the technical specifications. A list of subjects requiring further studies is also given.

Source (Quarry/Borrow area)	Processing / Treatment to bring to specifications
<b>Borrow area 15</b>	Remove materials > 700 mm which represents about 2-3% (for alluvium shoulders)
<b>Lyabidora</b>	Remove boulders > 100 mm which represents about 13 - 16 % (for transitions)
<b>Borrow area 17</b>	Reduce moisture content to 10-12 %. Remove materials > 200mm. Increase fine content
<b>Q 26 A and B</b>	Physical and mechanical properties are to be tested and defined precisely.

**Table 19: Processing/Treatment Specification**

### 3.2 Proposed Design

The Rogun site is very compact for a project of its size and the layout of the dam is imposed by numerous constraints:

- The existing diversion tunnels intakes: the upstream dam toe has to be set downstream of these intakes.
- The Ionakhsh Fault: the main dam or Stage 1 dam watertight component should not cross the Ionakhsh Fault, and should be set downstream from it. This aims at limiting the pore pressure grades across the Ionakhsh Fault, which increases salt dissolution.
- Fault 35: the main dam core should not cross this fault in order to avoid differential movement and shearing within the core.

Therefore, the Consultant has not modified the axis of the dam and kept it as planned by HPI for the three dam alternatives.

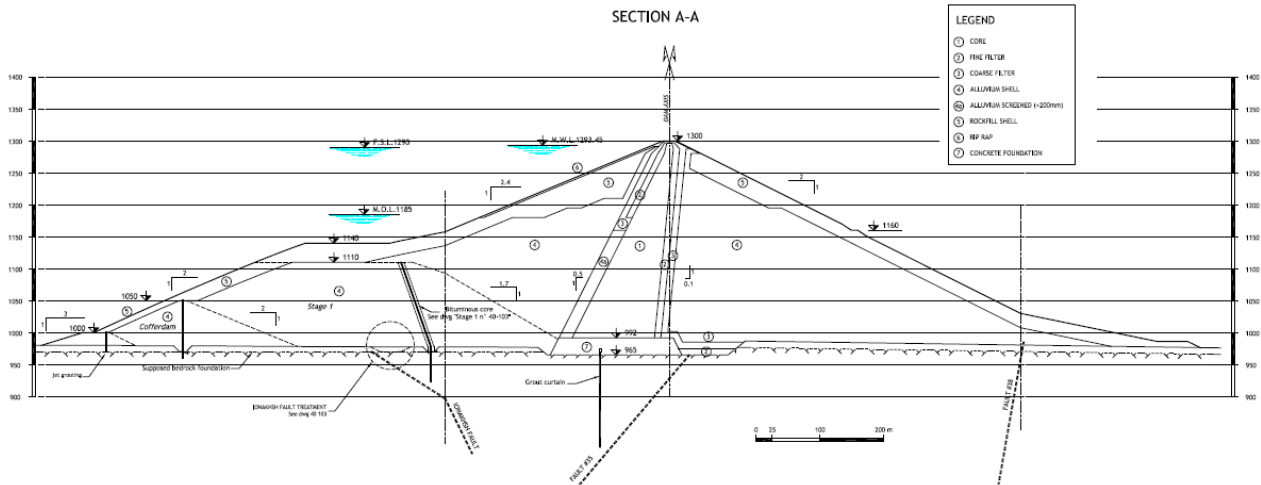

**Figure 12: Dam Cross Section. Alternative FSL=1,290 m.a.s.l.**

The material zoning recommended by the Consultant includes, upstream to downstream:

- A rip rap on the upstream slope above the minimum operating level;
- A rockfill layer of a minimum thickness of 20 m;
- The random alluvium material;
- A 10 m thick coarse filter;
- A 10 m thick fine filter;
- The core.

More information is given on the various material characteristics in Appendix 1.

### 3.3 Dam Stages

Rogun dam construction is phased in several construction steps: pre-cofferdam, cofferdam and Stage 1 dam, detailed in the table below.



Construction Phase		Description
Pre-cofferdam		Used to start the river diversion. Made of large blocks and random filling material
Cofferdam		Crest elevation=1,050 masl Upstream and Downstream slopes=2H/1V Volume=2.27 Mm <sup>3</sup> Includes a bituminous core
Stage 1 dam	General	Intermediate stage of main dam, allowing for early generation.
	FSL=1 290 masl	Crest elevation=1,110 masl
	FSL=1 255 masl	Crest elevation=1,090 masl
	FSL=1 220 masl	Crest elevation=1,075 masl
Main dam	FSL=1 290 masl	Crest elevation=1,300 masl Volume=74 Mm <sup>3</sup>
	FSL=1 255 masl	Crest elevation=1,265 masl Volume=55 Mm <sup>3</sup>
	FSL=1 220 masl	Crest elevation=1,230 masl Volume=35 Mm <sup>3</sup>

**Table 20: Construction Phases**

### 3.3.1.1 Implementation Schedule

The implementation schedule is necessary to evaluate the advantages and drawbacks of the various alternatives in terms of construction schedule and electricity production.

It has been derived assuming that the material placement rate is the same as the one presented in the “Implementation schedule and construction method” (Vol. 4 Chapter 1).

For all alternatives, the dimensions of the stage 1 step of construction have been optimized. This has also led to an optimization of the sequence of commissioning of intermediate units to ensure early generation during the construction of each proposed alternative.

### 3.3.1.2 Energy Production

The most important issue concerning the energy production during construction is the winter energy. All efforts have been made to optimize the winter energy production within the water sharing constraints agreed between riparian countries.

## 3.4 Dam Material

Currently, four quarries/borrow areas are considered suitable and adapted with respect to the specifications and constraints of the project:

- Borrow area 15 mainly for alluvium shoulders and transition and filter material,
- Stockpiles from Lyabidora borrow area to be used for transition and filters,
- Borrow area 17 for the dam core,
- Quarry 26 for rock shell and rip rap;
- Concrete aggregates are proposed to be processed from materials of borrow area 15.

Material / Alternative		Alt. 1290	Alt. 1255	Alt. 1220
1	Alluvium shell	43,063,864	33,182,921	18,924,605
2	Rockfill shell	17,365,059	12,475,052	9,352,361
3	Bituminous core	23,704	20,148	17,778
4	Core	6,992,490	5,104,518	3,714,728
5	Fine filter	2,466,655	1,350,195	747,638
6	Coarse filter	3,154,955	2,033,519	2,000,334
7	Rip rap	554,675	368,629	302,589
<b>TOTAL</b>		<b>73,621,402</b>	<b>54,534,982</b>	<b>35,060,033</b>

**Table 21: Material Quantities in-situ [m<sup>3</sup>]**

Materials	Assessment
Filter materials	Extracted primarily from Lyabidora. If not sufficient, extracted from BA15.
Concrete aggregates	Covered by the excess material from borrow area 15
Core materials	A comprehensive analysis on the impact of fine content on watertightness is awaited in order to fix the required fine content, and adapt the processes needed to meet these specifications
Moisture content of borrow area 17	Moisture control was taken into account in cost estimates by considering special storage conditions

**Table 22: Assessment of Materials**

### 3.5 Foundation Treatment

The dam foundation condition has been assessed in the Geotechnical Report (Phase 2 report, Vol. 1, Ch. 3). The excavation volumes necessary for the foundation are given below.

FSL=1290 masl	FSL=1255 masl	FSL=1220 masl
2.34 Mm <sup>3</sup>	1.73 Mm <sup>3</sup>	1.64 Mm <sup>3</sup>

**Table 23: Rock excavation volume**

### 3.6 Salt Wedge Treatment and Impact on Dam

This subject has been specifically addressed in the Phase 0 report, wherein all risks related to the presence of salt in the dam foundation have been assessed and mitigation measures provided to reduce them to an acceptable level. A complete monitoring plan has been set up to ensure that the efficiency of these recommended measures will be maintained throughout the project life.

#### 3.6.1 Description

The area is tectonically very active, and geodetic measurements carried out before 1978 demonstrate that both the Ionakhsh Fault and Fault 35 were creeping at a rate of about 1.5 to 2 mm per year.

When it comes to evaporites, and especially salt, leaching is a phenomenon that may be very rapid, and could generate significant consequences.

### **3.6.2 Mitigation Measures**

With the implementation of hydraulic and grouting barriers, related monitoring system, and the ability to undertake remedial works if and when required, a thorough analysis of the scenarios shows that the leaching issue at the Ionakhsh Fault does not affect the project feasibility.

## **3.7 Dam Instrumentation**

### **3.7.1 Main Dam**

The monitoring system is the only way to follow the dam behavior once constructed, and check that it is in agreement with its expected behavior. It is therefore of a prime importance to plan it at early study stages.

The dam movements are monitored thanks to:

- Topographical reflectors set on the dam crest and slopes;
- Settlement cells set inside the dam body;
- Accelerometers set on the dam crest and foundation.

The dam monitoring system should also include:

- A general topographic network with at least 6 landmarks that can be considered as constant (no movement).
- Series of piezometers and topographical reflectors on both banks.

### **3.7.2 Salt Wedge**

For the salt wedge surveillance, the recommendations are made in Phase 0 report and have been included in the overall monitoring recommendations for the dam.

## 4 RIVER DIVERSION AND MANAGEMENT OF CONSTRUCTION FLOODS

### 4.1 General Requirements

The management of River diversion and construction floods for the Rogun Project is a complex issue that is influenced and constrained by several points:

- The river hydrology and the construction schedule;
- The site topography;
- The existing structures;
- The early impounding of the reservoir and early energy generation;
- The following table presents the probability of occurrence chosen to be the protection level during the construction and the matching return period for each dam alternative.

		<b>Cofferdam</b>	<b>Stage 1</b>	<b>Completion of main dam</b>
<b>Probability of occurrence</b>		<b>1/100</b>	<b>1/100</b>	<b>1/200</b>
<b>Return period (year)</b>	FSL= 1290 m a.s.l	100	400	1200
	FSL = 1255 m a.s.l	100	300	1000
	FSL = 1220 m a.s.l	100	200	600

**Table 24: Construction Flood - Probability of Occurrence and Return Period**

- Diversion tunnels 1 and 2 shall work under a maximum head of 120 m, and their maximum discharge should preferably not exceed 1,600 m<sup>3</sup>/s/tunnel.
- A maximum head of 120 m is tolerated in tunnels during the construction period. This value can be overpassed by 30 m, i.e. 150 m, in extreme condition such as high floods or seismic events.
- The deposited material existing in the river downstream of the diversion outlets and due to a mudflow from Obi Shur creek has to be removed.

## 4.2 HPI Scheme for River Diversion and Management of Construction Floods

According to the HPI scheme, 6 different structures are used to divert and discharge the floods from river diversion to the completion of the final dam:

- Diversion tunnel of 1<sup>st</sup> level (DT1)
- Diversion tunnel of 2<sup>nd</sup> level (DT2)
- Diversion tunnel of 3<sup>rd</sup> level (DT3)
- Operational tunnel of 3<sup>rd</sup> level (OP3)
- Remote spillway (RS)
- Operational shaft spillway (OSS). The remote spillway and the operational shaft spillway share the same downstream tunnel and outlet.

Phase	Assessment
Cofferdam	Discharge capacity=2900 m <sup>3</sup> /s
Stage 1	Protected against PMF
Between Stage 1 and Elevation 1,185 m a.s.l	<p>When the reservoir level rises to 1,110 m a.s.l, DT2 and DT3 are able to discharge 4 400 m<sup>3</sup>/s if the DT2 discharge is limited by partially closing the gates orifice, and 5 200 m<sup>3</sup>/s if it is fully open.</p> <p>At 1,185 m a.s.l, the DT2, DT3 and remote spillway combined discharge capacity is of 6 400 m<sup>3</sup>/s, with half of this discharge actually passing through DT3.</p>
Above Elevation 1,185 m a.s.l	<p>Above 1,185 m a.s.l, the final spillways ensure the river diversion. At this elevation, OP3 and RS are able to discharge 4 650 m<sup>3</sup>/s, i.e. a lower capacity than in the previous phase.</p> <p>After dam completion, OP3 and RS would handle a head of 145 m in normal operation, which is higher than the limit considered acceptable by the Consultant for this type of structure.</p>

**Table 25: River Diversion Assessment**

### 4.3 Consultant's Proposed Scheme for River Diversion and Construction Flood Management

The entire river diversion management system initially proposed has been reviewed and updated based on the design criteria defined by the TEAS Consultant. This has led to extensive design changes and is believed to be an improvement of the overall safety of the project, both on the short term and the long run. The next table presents the diversion structures use for each dam alternative and each construction phase.

	Cofferdam	Stage 1	Final dam completion
FSL=1290 masl	DT1 + DT2 + DT3	DT1 + DT2 + DT3	MLO1+MLO2+HL1+HL2
FSL=1255 masl			MLO1+HL1+HL2+HL3
FSL=1220 masl			MLO1+HL1

**Table 26: Diversion structure for each dam alternative and each construction phase**

The cofferdam crest elevation is set at 1050 masl, ie 15 m above the one foreseen by HPI.

#### 4.3.1 DT1 and DT2

The existing 1<sup>st</sup> and 2<sup>nd</sup> level diversion tunnels develop in parallel at a distance between axes of some 45 to 58m, their intakes are placed shortly upstream of the pre-cofferdam, close to the intake of the Stage 1 headrace tunnel, and their floor elevations are set at 989.6 m.a.s.l for tunnel n°1 and 998.8 m.a.s.l for tunnel n°2.

Since the tunnels technical assessment contained in Phase 1 report concluded that the tunnels are not adequate in the present conditions for the purpose they have been designed for, measures adequate to improve their structural stability are necessary. Recommended interventions include the implementation of a pattern of dowels, a drainage system and an additional reinforced concrete lining, 30 or 40 cm min thickness in vault, 50 cm min on invert, with a horseshoe shape.

The reduction of the tunnels internal cross sectional area impacts to some extent on the tunnels discharge capacity. The revised discharge curve in final configuration calculated by the TEAS consultant shows that after the new lining is constructed, each tunnel can discharge a flow of about 1,325 m<sup>3</sup>/s at el 1,035 m a.s.l. and 1,525 m<sup>3</sup>/s at el 1,050 m a.s.l.

If the situation is considered in which the sector gates are not installed yet in diversion n° 2, those figures become 1,575 m<sup>3</sup>/s at el 1,035 m a.s.l. and 1,810 m<sup>3</sup>/s at el 1,050 m a.s.l.

The following operation ranges and conditions apply to the two diversion tunnels:

- Up to el. 1,035, with equipment totally installed the tunnels can operate with all gates open, discharging an aggregate maximum flow of 2,650 m<sup>3</sup>/s, and 2,900 m<sup>3</sup>/s if DT2 operates in provisional configuration, w/o sector gates;
- From 1,035 up to 1,050, DT2 also should operate with sector gates erected, maximum global discharge 3,050 m<sup>3</sup>/s;
- Above el. 1,050, in any case the flow would be such that the hydraulic jump would occur. Therefore, it is necessary to remove the deposited material and restore the original riverbed elevations downstream of the outlets so as to reduce tailwater levels. Whenever necessary, it is also possible to limit the flows by keeping one out of the three gates closed.

According to the floods management studies carried out, and on account of the criteria proposed for operating the discharge facilities, the discharge capacities needed at different elevations have been established. These analyses have confirmed that the construction of the third level diversion tunnel already proposed by HPI is necessary before diversion.

#### **4.3.2 Diversion Tunnel 3**

According to the latest HPI design, a further diversion tunnel was foreseen in the right bank of the river, which is needed to complement the discharge capacity of the existing diversion tunnels. At present, along the upstream stretch some first 400 m of tunnel excavation works have been already carried out in correspondence with the crown, reaching the beginning of the upstream transition of the proposed maintenance/emergency gates chamber. The Client agreed to implement the improvements to the design proposed by the TEAS Consultant while the construction progresses. It is deemed that the status of the works performed so far is such that any change can still be incorporated.

The concept and location of this tunnel has been substantially confirmed by the TEAS consultant, with some adjustments in the route required to accommodate the various hydraulic facilities.

The diversion tunnel n° 3 upstream stretch was located on the same alignment proposed by HPI and at the same intake elevation, i.e. 1,035 m a.s.l.



The pressure tunnel stretch, with circular cross-section of 15.0 m diameter, is about 810 m long up to the sector and emergency gates chamber. Downstream from this chamber, a horseshoe cross-section 14.5 m wide and 9.75 m to the springline with a circular arch roof reaching a maximum height of 17.0 m has been adopted.

The tunnel will cross both the Ionakhsh fault and fault 35, at some 700 m from its intake and at some 100 m before the outlet portal, respectively.

Therefore, in order to withstand the effects of creeping and/or possible large displacements resulting from seismic events, a very thick highly reinforced concrete lining divided into short stretches (rings) along the reach of the shear zone will be implemented for both fault crossings: in case of differential movements, these may undergo displacements, but the tunnel cavity will remain intact.

Further to this, it is proposed to equip the first gate chamber with wheel gates that can be operated under flow with the maximum head. This would allow, in case of damages to the inner lining and blocking of the downstream gates, the tunnel to be closed so that repair works could be carried out.

In order to prevent cavitation, a number of measures have been foreseen. These include steel lining along the stretches close to the gates, aeration provisions downstream from the gates and very gradual transitions to the tunnel current cross section.

At the tunnel outlet, a short chute some 90 m long with terminal flip bucket located a few meters above the river water level (1004.3 m a.s.l.) has been foreseen. Pre-excavation of a plunge pool is recommended, following the evaluation of possible scour effects.

Such a tunnel would be capable of discharging 1,325 m<sup>3</sup>/s with the reservoir water level at 1,055 m a.s.l. and 2,450 m<sup>3</sup>/s when the water level reaches 1,100 m a.s.l.

All features of Diversion Tunnel N° 3 remain unchanged for all dam alternatives.

### **4.3.3 Middle Level Outlets MLO1 and MLO2**

#### ***Middle Level Outlet 1***

The Middle Level Outlet 1 is required for protecting the dam, starting from water elevation 1,100.0 m a.s.l., which is considered as the limit of normal operation of Diversion Tunnels N° 1 and 2 (120 m head).

The general features of pressure tunnel stretch are the same as those of Diversion tunnel N° 3. The elevation of the tunnel invert at the portal is 1085.0 m a.s.l. The tunnel is provided with maintenance and sector & emergency gate chambers.

The intake arrangement foresees a concrete culvert some 300 m long, made by short stretches some 30 m long, crossing the dam upstream embankment up to the underground stretch portal, so that the tunnel proper is starting shortly downstream from the Ionakhsh fault crossing. Possible displacements at Ionakhsh fault section can occur without interrupting the hydraulic route to the tunnel.

The outlet area elevation is around 1075 m a.s.l., which is about 100 m higher than the riverbed: thus the problem of discharging the flow, which is about 3700 m<sup>3</sup>/s, to the river required proper consideration, to avoid undesirable scouring effects which might also trigger bank instability.

Various alternatives for MLO1 outlets have been studied and are presented in the Appendix 4 of the present chapter. Finally, it has been chosen to make use of the cascade system envisaged at the outlet of the surface spillway, constituted by a sequence of chute and stilling basins.

The MLO1, outlet elevation is very close to the surface spillway bucket

The tunnel pressure stretch, 15 m diameter, is branching into two circular tunnels with 10.8 m inner diameter, each provided with an emergency and sector gates chamber, running along the same axes of the surface spillway and connected with two corresponding channels.

This solution was thus definitively adopted for MLO1, in view of the following advantages:

- Reduced number of outlets in the Vakhsh River left bank;
- Lower specific flow at the outlet and correspondingly reduced scour in the riverbed;
- The crossing with faults 35 and other shearing zone is avoided;

All features of MLO1 remain unchanged for all dam alternatives.

Provisions similar to those designed for DT3 have been recommended in order to reduce the risks of cavitation.

### ***Middle Level Outlet 2***

The possibility to discharge the flow into the surface spillway was also analyzed for this hydraulic facility, but it was found not applicable due to the different hydraulic and geometrical conditions.

Therefore, the solution with vortex shafts was adopted for MLO2.

The intake is set at El. 1,140.0, and the pressure tunnel exhibits circular cross-section of 15.0 m diameter. The tunnel is provided with maintenance and emergency & sector gate chambers. Downstream from the sector and emergency gate chamber, a d-shaped cross section 15.8 m wide and 17 m high has been adopted, divided in two halves by a 1.80 m thick wall, each half flowing into a vortex drop shaft, which discharges to the river through a free flow tailrace tunnel, provided with terminal chute and flip bucket.

Applications of vortex shafts are becoming more and more frequent, and no drawbacks have been reported in respect to their behaviour, even if the existing prototypes apparently have not been working under flows as high as that proposed for Rogun. The Consultant deems that with proper model testing, this solution can be adopted for the Project.

Provisions have been made at the crossing of tailrace tunnels with fault 35 and other shearing zone, similar to those adopted for the case of DT3.

For MLO2, the water discharge reaches 3,710 m<sup>3</sup>/s for the maximum exceptional head of 150 m, being the individual flow of each discharge equal to 1,855 m<sup>3</sup>/s.

The geometrical features of the upstream stretch, the operation modes and the provisions adopted for MLO2 to avoid cavitation problems are conceptually the same as those implemented for MLO1.

#### ***4.3.4 High level tunnels***

The diversion scheme is completed with the High Level tunnels that are also use as operational spillways. Their description is therefore presented in the next paragraph.

## 5 EXTREME FLOOD MANAGEMENT

### 5.1 Design criteria

The floods considered for the protection of Rogun dam are the PMF and the 10 000 years return period flood, as stated in the Design criteria, which are as follows:

Return period	Peak (m <sup>3</sup> /s)	Daily (m <sup>3</sup> /s)
10 000 years	5970	5690
PMF	8160	7770

**Table 27 : Peak and daily maximum discharge**

Assuming N orifice spillways and n gates for the surface spillway:

- for the 10 000 years flood, either with N-1 orifice spillways or with the n-1 gates of the surface spillway(s) (n-2 if the number of gates is more than 6), the maximum water level should be not higher than the top of the dam core.
- For the PMF, with the N orifice spillways and the n gates of the surface spillway, the maximum water level should be not higher than the top of the dam core.

In addition, several safety principles are taken into account:

- The PMF is an exceptional extreme event during which the access to the power plant could be dangerous or unavailable. Therefore, the turbines cannot be considered as a spilling facility in the overall spillage capacity of Rogun but only dedicated spillage facilities will be considered.
- The consultant's practice and recommendation is not to rely on tunnel spillways only: they are subject to operational and maintenance issues and they are not flexible with respect to any variation above the design discharge.
- The maximum normal water head in tunnel shall be limited to 120 m as already stated earlier.
- All discharge facilities shall be independent.

- It is recommended to avoid fault crossing as much as possible and to adopt a special design when it is not possible to avoid such crossing to handle part of displacements and maintain the integrity of the structure.

Also it is required that the Rogun reservoir should protect the downstream cascade by attenuating the PMF.

## 5.2 Spillways

Following the studies on Flood Management during Construction”, the following tunnel spillways remain available at the end of construction as high level spillway:

Dam alternative	Number of tunnels available	Number of gates per tunnel	Intake elevation of tunnels
FSL = 1220 masl	1	3	1140 masl
FSL = 1255 masl	3	3	1 at 1145 masl and 2 at 1165 masl
FSL = 1290 masl	2	3	1190 masl

**Table 28 : Number of tunnels available at the end of construction**

These tunnels can remain in operation as the operating head does not exceed the criterion fixed by the Consultant (120 m), until the sediments deposit reach their respective intake level.

Additionally, surface spillways modules will be available, with the following general features:

Dam alternative	Number gates per waterway / module	Width of the gates	Sill Elevation
FSL = 1220 masl	4	8m	1214 masl
FSL = 1255 masl	4	8m	1249 masl
FSL = 1290 masl	4	8m	1284 masl

**Table 29 : Surface spillway characteristics**

For each alternative, several combinations of spillway facilities (numbers and types) have been studied with respect to the design criteria and safety principles, as well as their sensitivity to the relevant parameters.

### **5.2.1 Recommendations**

#### **Alternative FSL = 1220 masl**

It is recommended to implement at Rogun the option with 2 surface spillways and 1 tunnel. It is recommended to add, at least, a surface spillway at Nurek to ensure protection of the dam against the PMF. The value of these works has been taken into consideration as the minimal value for the works to be implemented on the Cascade if this alternative is chosen.

#### **Alternative FSL = 1255 masl**

It is recommended to implement at Rogun the option with 3 tunnels and 1 surface spillway.

#### **Alternative FSL = 1290 masl**

It is recommended to implement at Rogun the option with 2 tunnels and 1 surface spillway.

#### **Long term**

In the long term, when the reservoir sedimentation will prevent the discharge of the floods through high level spillway tunnels, the complete surface spillway configuration – made of three modules – will be required for all dam alternatives.

### **5.2.2 High Level Tunnels spillways**

The high level spillways are constituted by a set of tunnels working under a maximum head of about 80-110 m with individual maximum discharge capacity close to 1,500 m<sup>3</sup>/s.

They were placed some 30 m higher than the power intakes, so to assure that they will remain operative as long as possible, even if sediments would reach the headrace tunnels.

The most upstream of the tunnels has been located some 15-20 m downstream from the Ionakhsh fault, so to avoid as much as possible that creeping or displacements impact on the structure stability.

Each tunnel was provided with maintenance gates and emergency & sector gate chambers, following the concept adopted in other tunnels.

The elevation and number of high-level tunnel spillways for the different alternatives are as follows:

- Alternative with FSL 1290: two HLTS with intake at el. 1,190.0 m a.s.l.
- Alternative with FSL 1255: three HLTS, out of which one with intake at el. 1,145.0 m a.s.l. and the remaining two with intake at el. 1,165.0 m a.s.l.
- Alternative with FSL 1220: one HLTS with intake at el. 1,140.0 m a.s.l.

Concerning the outlets, energy dissipation and flow release in the river, various alternatives have been analyzed, having in mind the risks related to cavitation due to the high water speed and potential scouring effects which may trigger banks instability.

The solution constituted by the vortex spillways in this case was not taken into consideration, due to the height of the shaft required.

The goal to control cavitation risks and to dissipate as much energy as possible was achieved thanks to a cascade system of chute and stilling basins, thus reducing substantially the problem of scour in the river. Details of this structure are presented in Appendix 3.

The above outlined solution has been adopted for all HLTS proposed, adapting to the morphological conditions and difference in total elevation the slopes and height of the chutes.

### **5.2.3 Surface spillway**

The surface spillway, as an ultimate stage flood evacuation organ, should replace in the long term the flood evacuation organs planned for the beginning of the useful life of the project (first stage evacuation organs). Its discharge capacity must be, accordingly, equal to the peak discharge of the Probable Maximum Flood (PMF), and is to be designed and built in such a way that erosion damage caused by sediments running along it can be easily repaired by isolating part of the spillway.

The spillway structure consists of three independent conduits, each of them featuring an approach bay with a control sill equipped with four gated bays, a free-flow tunnel excavated through the high hill on the right bank, an open air stepped chute channel with intermediate energy dissipation given by stilling basins and a flip bucket end structure in the last step of the chute. A plunge pool in the river bed is also recommended.

Only one “module” will be required in the initial stage of the project operation for alternatives with FSL 1290 and 1255, whilst two modules are adopted for the alternative with FSL 1220. For the

two highest alternatives, this is a consequence of the need of keeping the flow discharged from Rogun within values which assure that the safety of Nurek is not impaired.

The final complete configuration, constituted by three modules, will be needed in the long term, once the reservoir sedimentation will prevent the discharge of the floods through other hydraulic facilities, in particular the high level spillway tunnels.

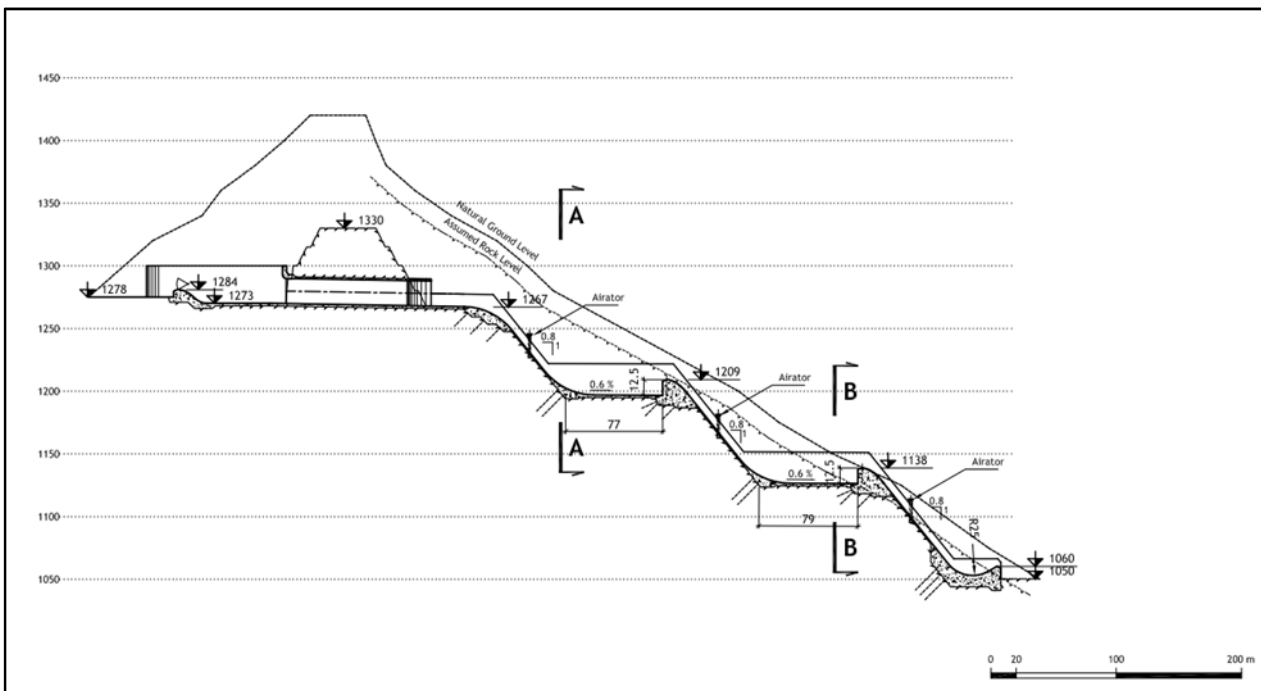

Figure 13: Longitudinal section of the stepped spillway

## 6 MULTI LEVEL INTAKES

The total yearly solid run-off of the Vakhsh River is estimated to range between 87 and 140 millions of tons per year, or between 62 and 100 Million m<sup>3</sup> per year, which represent a serious drawback for the plant, since it has a considerable impact on the useful lifespan of the project and on the energy generation.

Possible alternatives for mitigating such negative impacts have been analyzed, to find out the most effective one that can be implemented within a reasonable range of cost.

The possibility to perform at least the sediment flushing through tunnels located in the left bank, just below the power intakes, was analyzed and finally abandoned due to various drawbacks in the operation.



Therefore, instead of the usual intake with single front entrance, multi-level intakes were proposed, which allow deriving the flow from the reservoir at different elevations. The benefits of the proposed intakes are two-fold: from one side it is possible to bring water to the power waterways even when the sediments deposit will be higher than the headrace tunnel elevation, extending thus the plant life by several decades, on the other side it is also possible to pass turbidity currents, if it is proved to be a viable option, though the turbines, which may have also the effect to extend the time by which the plant shall be put out of operation.

The multi-level intakes solution proposed for Rogun consists of an inclined concrete culvert, resting on the bank slope in correspondence with the power waterways inlets, provided with openings at various levels up to the dam crest elevation.

## 7 POWER HOUSE

The Powerhouse Cavern, located in a sedimentary complex constituted by sandstone and siltstone, is approximately 21 m wide, 69 m high and 220 m long.

The present status of the powerhouse has been already discussed in detail in Phase I assessment, in which the existing problems were also underlined and the progress of the analyses carried out reported.

As a conclusion, a set of stabilization measures is proposed, which include rock anchors 35 m long on both sidewalls and stabilization/strengthening of the rock mass of the pillar between the Powerhouse and Transformers caverns in the Units 5 and 6 zone, to be achieved by installing steel piles with properly spaced valves to allow for consolidation grouting (Multiple Packer Sleeved Pipe system). As a possible alternative, an intensive consolidation grouting campaign can be carried out and tendons with two heads crossing the whole pillar in between the two caverns be installed. The most adequate solution shall be evaluated in detail at a later design stage

The provision of a suitably distributed monitoring system before proceeding with the next excavation stages is considered mandatory.

The maximum installed capacity to be considered in the studies of the alternatives is 3,600 MW, i.e. the capacity for which the present structure has been designed. For the above, the powerhouse can accommodate the generation equipment corresponding to the various alternatives

proposed in the studies, which foresee the same number of units as the original scheme, without need for major modifications.

## 8 ELECTRO-MECHANICAL EQUIPMENT

According to the design carried out by HPI for dam at FSL = 1,290, the powerhouse is equipped with six Francis units, each rated 600 MW and working under a barycentric head of 268 m. The project foresees a preliminary arrangement for the startup of generation when the dam is under construction.

As indicated in other sections of the report, the following alternatives have been analyzed:

	FSL = 1220 m asl	FSL = 1255 m asl	FSL = 1290 m asl
<b>High installed capacity</b>	2 800 MW	3 200 MW	3 600 MW
<b>Medium installed capacity</b>	2 400 MW	2 800 MW	3 200 MW
<b>Low installed capacity</b>	2 000 MW	2 400 MW	2800 MW

**Table 30 : Alternatives to be studied**

Preliminarily for each alternative the number of units, capacity and other main features have been defined, as reported in the table of the section “Key data for each alternative”.

The generating units have been defined considering units of capacity not higher than that of the original design that is in the order of 600 MW.

The same number of units has been adopted for all options, in consideration of the present progress of the works, so that the flow can be evenly distributed in the two existing tailrace tunnels.

In consideration that there are two already excavated tailrace tunnels, the number of units to be installed shall be pair, so that all hydraulic characteristics will be the same in both of them. An increase of the number of units would cause problems in the layout and would require modification of works already done, which are deemed not possible at this stage.

Therefore the only possible modification in the number of units would be to reduce them from six to four. Such change would have a very marginal impact on the total cost of the plant but it would imply an increase in the unit capacity for all alternatives, except for the case of 2000 MW.

The feasibility of units with capacities higher than that presently foreseen should be carefully investigated. In addition, the problem of the transportation of very large units shall be taken into

account, as well as the possible future serious problems in case maintenance operations are required. Obviously, by reducing the unit capacity from 600 MW to lower values, the transportation problems are also more manageable.

## 9 KEY DATA FOR EACH ALTERNATIVE

### 9.1 Dam

	FSL = 1290 m a.s.l	FSL = 1255 m a.s.l	FSL = 1220 m a.s.l
<b>Dam crest</b>	1300 m a.s.l	1265 m a.s.l	1230 m a.s.l
<b>Foundation level</b>	965 m a.s.l	965 m a.s.l	965 m a.s.l
<b>Dam height</b>	335 m	300 m	265 m
<b>Crest length</b>	660 m	565 m	500 m
<b>Crest width</b>	20 m	20 m	20 m
<b>Core crest level</b>	1296.25 m a.s.l	1261.25 m a.s.l	1226.25 m a.s.l
<b>Maximum water level</b>	1296 m a.s.l	1261 m a.s.l	1226 m a.s.l
<b>Minimum operational level</b>	1185 m a.s.l	1161 m a.s.l	1137 m a.s.l
<b>Reservoir active storage</b>	10 300 hm <sup>3</sup>	6 454 hm <sup>3</sup>	3 927 hm <sup>3</sup>
<b>Total reservoir capacity</b>	13 300 hm <sup>3</sup>	8 550 hm <sup>3</sup>	5 220 hm <sup>3</sup>
<b>Average yearly inflows</b>	20 100 hm <sup>3</sup>	20 100 hm <sup>3</sup>	20 100 hm <sup>3</sup>
<b>Dam slopes</b>	US 2.4 H/1V DS 2 H/1V	US 2.4 H/1V DS 2 H/1V	US 2.4 H/1V DS 2 H/1V
<b>Stage 1 elevation</b>	1110 m a.s.l	1090 m a.s.l	1075 m a.s.l
<b>Core crest thickness</b>	8 m	8 m	8 m
<b>Core slopes</b>	US: 0.5 H/1V DS -0.1 h/1V	US: 0.5 H/1V DS -0.1 h/1V	US: 0.5 H/1V DS -0.1 h/1V
<b>Filters thickness</b>	US: 2 layers of 10 m each above the minimum operation level and one layer of 10 m below DS: 2 layers of 10 m each	US: 2 layers of 10 m each above the minimum operation level and one layer of 10 m below DS: 2 layers of 10 m each	US: 2 layers of 10 m each above the minimum operation level and one layer of 10 m below DS: 2 layers of 10 m each

## 9.2 River Diversion Structures

	FSL = 1290 m a.s.l	FSL = 1255 m a.s.l	FSL = 1220 m a.s.l
<b>Diversion tunnel 1</b>			
<i>Total tunnel length</i>	1439.5 m	1439.5 m	1439.5 m
<i>Pressure Stretch Section (D-Shape)</i>	96.55 m <sup>2</sup>	96.55 m <sup>2</sup>	96.55 m <sup>2</sup>
<i>Low intake level</i>	989.60 m a.s.l	989.60 m a.s.l	989.60 m a.s.l
<i>High intake level</i>	1020 m a.s.l	1020 m a.s.l	1020 m a.s.l
<i>Design head</i>	120 m	120 m	120 m
<i>Minimum operational level</i>	989.60 m a.s.l	989.60 m a.s.l	989.60 m a.s.l
<i>Maximum operational level</i>	1110 m a.s.l	1110 m a.s.l	1110 m a.s.l
<i>Design discharge</i>	2490 m <sup>3</sup> /s	2490 m <sup>3</sup> /s	2490 m <sup>3</sup> /s
<b>Diversion tunnel 2</b>			
<i>Total tunnel length</i>	1420.7 m	1420.7 m	1420.7 m
<i>Pressure Stretch Section (D-Shape)</i>	96.55 m <sup>2</sup>	96.55 m <sup>2</sup>	96.55 m <sup>2</sup>
<i>Low intake level</i>	1001.80 m a.s.l	1001.80 m a.s.l	1001.80 m a.s.l
<i>High level intake</i>	1020 m a.s.l	1020 m a.s.l	1020 m a.s.l
<i>Design head</i>	120 m	120 m	120 m
<i>Minimum operational level</i>	1001.80 m a.s.l	1001.80 m a.s.l	1001.80 m a.s.l
<i>Maximum operational level</i>	1110 m a.s.l	1110 m a.s.l	1110 m a.s.l
<i>Design discharge</i>	2490 m <sup>3</sup> /s	2490 m <sup>3</sup> /s	2490 m <sup>3</sup> /s
<b>Diversion tunnel 3</b>			
<i>Total tunnel length</i>	1560 m	1560 m	1560 m
<i>Diameter of Pressure Stretch</i>	15 m	15 m	15 m
<i>Intake level</i>	1035.0 m a.s.l	1035.0 m a.s.l	1035.0 m a.s.l
<i>Outlet portal level</i>	1023.45 m a.s.l	1023.45 m a.s.l	1023.45 m a.s.l
<i>Design head</i>	150 m	150 m	150 m
<i>Minimum operational level</i>	1035 m a.s.l	1035 m a.s.l	1035 m a.s.l
<i>Maximum operational level</i>	1160 m a.s.l	1170 m a.s.l	1165 m a.s.l
<i>Design discharge</i>	3694 m <sup>3</sup> /s	3694 m <sup>3</sup> /s	3694 m <sup>3</sup> /s

The data refers to the condition of maximum exceptional head.

## 9.3 Spillways

### 9.3.1 Middle Level Outlet

	FSL = 1290 m a.s.l	FSL = 1255 m a.s.l	FSL = 1220 m a.s.l
<b>Middle level outlet 1</b>			
<i>Total tunnel length</i>	1464.0 m	1464.0 m	1464.0 m
<i>Diameter of Pressure Stretch (Circular)</i>	15 m	15 m	15 m
<i>Intake level</i>	1083.50 m a.s.l	1083.50 m a.s.l	1083. 50 m a.s.l
<i>Outlet tunnel level</i>	1077.60 m a.s.l	1077.60 m a.s.l	1077.60 m a.s.l
<i>Design head</i>	150 m	150 m	140 m
<i>Minimum operational level</i>	1100.0 m a.s.l	1100.0 m a.s.l	1100.0 m a.s.l
<i>Maximum operational level</i>	1215 m a.s.l	1210 m a.s.l	1210 m a.s.l
<i>Design discharge</i>	3685 m <sup>3</sup> /s	3564 m <sup>3</sup> /s	3562 m <sup>3</sup> /s
<b>Middle level outlet 2</b>			
<i>Total tunnel length</i>	1117.0 m		
<i>Diameter of Pressure Stretch (Circular)</i>	15 m		
<i>Intake level</i>	1140 m a.s.l		
<i>Outlet tunnel level</i>	1026.80 m a.s.l		
<i>Design head</i>	150 m		
<i>Minimum operational level</i>	1215 m a.s.l		
<i>Maximum operational level</i>	1270 m a.s.l		
<i>Design discharge</i>	3710 m <sup>3</sup> /s		

The data refers to the condition of maximum exceptional head.

### 9.3.2 High level tunnels

	FSL = 1290 m a.s.l	FSL = 1255 m a.s.l	FSL = 1220 m a.s.l
<b>High level tunnel 1</b>			
<i>Total tunnel length</i>	1264.1 m	1385.7 m	1416.8 m
<i>Diameter of Pressure Stretch (Horse-shoe)</i>	10 m	10 m	10 m
<i>Intake level</i>	1190 m a.s.l	1145 m a.s.l	1140 m a.s.l
<i>Outlet tunnel level</i>	1177.70 m a.s.l	1131.74 m a.s.l	1126.30 m a.s.l
<i>Outlet Structure level</i>	1000.00 m a.s.l	1000 m a.s.l	1000 m a.s.l
<i>Outlet Spillway length</i>	440.3 m	376.6 m	367.3 m
<i>Design head</i>	100 m	110 m	80 m
<i>Minimum operational level</i>	1190 m a.s.l	1145 m a.s.l	1140 m a.s.l
<i>Maximum operational level</i>	1290 m a.s.l	1255 m a.s.l	1220 m a.s.l
<i>Design discharge</i>	1570 m <sup>3</sup> /s	1640 m <sup>3</sup> /s	1410 m <sup>3</sup> /s
<b>High level tunnel 2</b>			
<i>Total tunnel length</i>	1410.1 m	1501.6	
<i>Diameter of Pressure Stretch (Horse –shoe)</i>	10 m	10 m	
<i>Intake level</i>	1190 m a.s.l	1165 m a.s.l	
<i>Outlet tunnel level</i>	1176.57 m a.s.l	1151.66 m a.s.l	
<i>Outlet Structure level</i>	1000 m a.s.l	1000 m a.s.l	
<i>Outlet Spillway length</i>	415.9 m	385.6 m	
<i>Design head</i>	100 m	90 m	
<i>Minimum operational level</i>	1190 m a.s.l	1165 m a.s.l	
<i>Maximum operational level</i>	1290 m a.s.l	1255 m a.s.l	
<i>Design discharge</i>	1570 m <sup>3</sup> /s	1490 m <sup>3</sup> /s	
<b>High level tunnel 3</b>			
<i>Total tunnel length</i>		1585.1 m	
<i>Diameter of Pressure Stretch (Horse –shoe)</i>		10 m	
<i>Intake level</i>		1165 m a.s.l	
<i>Outlet tunnel level</i>		1149.85 m a.s.l	
<i>Outlet Structure level</i>		1000 m a.s.l	
<i>Outlet Spillway length</i>		371.2 m	
<i>Design head</i>		90 m	
<i>Minimum operational level</i>		1165 m a.s.l	
<i>Maximum operational level</i>		1255 m a.s.l	
<i>Design discharge</i>		1490 m <sup>3</sup> /s	

The data refers to the condition of maximum exceptional head.

### 9.3.3 Multi-level Intakes

	FSL = 1290 m asl	FSL = 1255 m asl	FSL = 1220 m asl
<i>Intakes culverts developed length</i>	312.5 m	259.1 m	205.8 m
<i>Culverts Inner Dimensions</i>	16 x 12 m	16 x 12 m	16 x 12 m
<i>Upper Power Intakes level (Units 1, 2, 5, 6)</i>	1167 masl	1140 masl	1115 masl
<i>Lower Power Intakes level (Units 3, 4)</i>	1152 masl	1130 masl	1150 masl
<i>Number of Intakes active inlets</i>	4	3	2
<i>Higher Intakes active inlets level</i>	1179.3 masl	1154.3 masl	1129.3 masl
<i>Lower Intakes active inlets level</i>	1104.3 masl	1104.3 masl	1104.3 masl
<i>Power Intakes Gates Design Head</i>	140 m	130 m	115 m

### 9.3.4 Surface Spillway

	FSL = 1290 m a.s.l	FSL = 1255 m a.s.l	FSL = 1220 m a.s.l
<b>First Stage</b>			
<i>Number of modules</i>	1	1	2
<i>Number of tunnels</i>	2	2	4
<b>Final Stage</b>			
<i>Number of modules</i>	3	3	3
<i>Number of tunnels</i>	6	6	6
<b>Tunnel width (D-shape)</b>	9.40 m	9.40 m	9.40 m
<b>Tunnel height (D-shape)</b>	15 m	15 m	15 m
<b>Fall height</b>	224 m	189 m	154 m
<b>Number intermediate spillways</b>	2	2	1
<b>Width of intermediate spillways</b>	33 m	33 m	33 m
<b>Design discharge (PMF)</b>	7800 m <sup>3</sup> /s	7800 m <sup>3</sup> /s	7800 m <sup>3</sup> /s
<b>Sill level</b>	1284 m a.s.l	1249 m a.s.l	1214 m a.s.l
<b>Flip bucket exit level</b>	1060 m a.s.l	1060 m a.s.l	1060 m a.s.l
<b>Minimum operational level</b>	1284 m a.s.l	1249 m a.s.l	1214 m a.s.l
<b>Maximum operational level</b>	1296 m a.s.l	1261 m a.s.l	1226 m a.s.l

## 9.4 Powerhouse and EM Equipment

### Final Dam Elevation 1,290 m a.s.l.

<b>Total Installed Capacity (MW)</b>	<b>3600</b>	<b>3200</b>	<b>2800</b>
<b>Number of units</b>	6	6	6
<b>Number of units reused (*)</b>	2	2	2
<b>Pmax (MW)</b>	600	533.3	466.7
<b>Pmin (MW)</b>	360	270	245
<b>Hmax (m)</b>	320	320	320
<b>Hmin (m)</b>	185	185	185
<b>Hrated (m)</b>	285	285	285
<b>Rpm</b>	166.7	166.7	166.7

### Final Dam Elevation 1,255 m a.s.l.

<b>Total Installed Capacity (MW)</b>	<b>3200</b>	<b>2800</b>	<b>2400</b>
<b>Number of units</b>	6	6	6
<b>Number of units reused (*)</b>	2	2	2
<b>Pmax (MW)</b>	533.3	466.7	400
<b>Pmin (MW)</b>	260	225	200
<b>Hmax (m)</b>	285	285	285
<b>Hmin (m)</b>	131	131	131
<b>Hrated (m)</b>	210	210	210
<b>Rpm</b>	125	125	125



**Final Dam Elevation 1,220 m a.s.l.**

<b>Total Installed Capacity (MW)</b>	<b>2800</b>	<b>2400</b>	<b>2000</b>
<b>Number of units</b>	6	6	6
<b>Number of units reused (*)</b>	2	2	2
<b>Pmax (MW)</b>	466.7	400	333
<b>Pmin (MW)</b>	190	170	145
<b>Hmax (m)</b>	250	250	250
<b>Hmin (m)</b>	107	107	107
<b>Hrated (m)</b>	190	190	190
<b>Rpm</b>	125	125	150

(\*) Adopting final runners since the commissioning

## **CHAPTER 3.3: APPENDIX 1 – CONSTRUCTION MATERIAL ASSESSMENT**

### **1 INTRODUCTION**

This report is to be considered in the continuity of the Phase I report on construction materials that aimed at assessing existing facilities including stockpiled materials. In this report, the Consultant lays down the technical specifications for the materials to be placed in the dam body in order to assess the overall suitability of identified sources of material and therefore establish the feasibility of the different alternatives studied. This assessment is also taken into consideration in the cost estimate of the project alternatives developed in Volume 4 of the Phase II report.

### **2 DAM DESIGN – QUANTITIES OF NEEDED MATERIALS**

The quantities of materials required for each alternative developed by the TEAS Consultant are as follows:

	Dam part	Alternative 1 300 m Quantity	Alternative 1 265 m Quantity	Alternative 1 230 m Quantity
	<i>[-]</i>	<i>[m<sup>3</sup>]</i>	<i>[m<sup>3</sup>]</i>	<i>[m<sup>3</sup>]</i>
<b>1</b>	Core	6 992 490	5 130 207	3 714 728
<b>2 - 3</b>	Fine filters	5 621 610	3 383 714	3 366 184
	Coarse filters			
<b>4</b>	Shoulders materials	43 063 864	33 182 921	18 924 605
<b>5</b>	Rock fill / Rock shell	17 365 059	12 475 052	9 352 361
<b>6</b>	Rip rap	554 675	368 629	302 589
<b>7</b>	Concrete slab under the core	354 405	329 782	308 811
<b>Total</b>	<i>(excluding concrete slab)</i>	<b>73 597 698</b>	<b>54 540 523</b>	<b>35 660 467</b>

**Table 31: Main Required Quantities for Dam Construction**

The following chapters of this report are based on the volumes of materials for the alternative at crest elevation at 1 300 m a.s.l. Because it is the dam alternative which requires the most important quantities of materials, the conclusions concerning materials availability for this alternative will be applicable to the smaller alternatives.

### 3 MATERIALS CHARACTERISTICS

#### 3.1 Source of Materials

Currently, four quarries/borrow areas are considered suitable and adapted with respect to the specifications and constraints of the project:

- Borrow area 15 mainly for alluvium shoulders and transition and filter material,
- Stockpiles from Lyabidora borrow area to be used for transition and filters,
- Borrow area 17 for the dam core,

- Quarry 26 for rock shell and rip rap.
- Concrete aggregates are proposed to be processed from materials of borrow area 15.

The volumes needed for the dam are available in quarries / borrow areas and associated storages. The filter materials are to be used as a priority from stockpiles already available after extraction from the borrow area of Lyabidora. The volumes are however not sufficient in this stockpile, and the missing volumes are to be extracted from borrow area 15, and processed in order to meet filter specifications. Special attention shall be given to the timely extraction of material from BA 15, as this borrow area is bound to be flooded in the early stages of construction.

The necessary quantities of concrete aggregates are covered by the excess materials from borrow area 15, which presents a large grading suitable for concrete aggregate purposes, and by considering a specific treatment and selection of suitable materials.

A first estimation of losses and expansion/compaction coefficients has been done and the results are summarized in the Table below with adapted quantities of materials with respect to TEAS consortium recommendations on dam design:

Quarry / Borrow area		15	Lyabidora	17	26 a	26 b	11
Material type		Gravels	Gravels	Loam	Rock	Rock	Pure clay
Volumes in the quarries [Mm <sup>3</sup> ]	Initial total volume	49.0	5.0	17.0	5.5	18.0	-
	Extracted volume	22.0	4.0	2.5	0.8	0.0	-
	Needed volume	42.0	4.4	6.6	19.3		-
Coefficient due to expansion after extraction	%	12.0%	12.0%	20.0%	35.0%	35.0%	
Loss percentage due to poor quality of material	%	11.6%	2.0%	4.1%	10.0%	10.0%	
Transport losses	%	0.1%	0.1%	0.1%	2.1%	2.1%	
Compaction coefficient	%	9.0%	9.0%	15.0%	10.0%	10.0%	
Overall coefficient	%	91%	101%	100%	108%	108%	-
Corresponding volumes in the quarries / Borrow areas	[Mm <sup>3</sup> ]	46.6	4.4	6.8	5.1	12.9	-

**Table 32: Estimation of Losses and Expansion/Compaction Coefficients**

### 3.2 Materials characteristics

The following table presents the main characteristics of the materials according to studies and investigations.

		Dry unit weight	Saturated unit weight	Porosity	Friction angle	Cohesion	Deformation modulus	Poisson's ratio	Permeability	Moisture at placement
Dam zone		$\gamma_{dry}$	$\gamma_{sat}$	n	$\phi$	C	E	$\nu$	K	
		[kN/m <sup>3</sup> ]	[kN/m <sup>3</sup> ]	[-]	[°]	[MPa]	[MPa]	[-]	[cm/s]	[%]
1	Core	23,6	23,9	0,19	31	0,03	40	0,36	$A \cdot 10^{-6}$	9 - 11 %
2	Fine transition	22,1	23,2	0,22	36	0	55	0,32	$3 \cdot 10^{-2}$	5%
3	Coarse transition	22,6	23,5	0,2	40	0	65	0,3	$5 \cdot 10^{-2}$	5%
5	Alluvium shoulders	23,1	23,8	0,18	39	0,05	80	0,27	0,1	5%
4	Rockfill	19,9	21,9	0,3	42	0,03	60	0,28	0,5	-

**Table 33: Main Characteristics of Materials for Dam Construction**

The dam stability analysis confirmed these characteristics.

### 3.3 Specifications for Materials Grading

#### 3.3.1 Presentation of Design Criteria

The main design specifications refer to the definition of the grading curves of materials. The definitions of the grading curves are subjected to design criteria presented in the Design criteria report (TEAS Consultant). The design criteria on grading curves are based on ICOLD 1994 – Bulletin 95 and summarized below:

- **Internal stability (self-filtering property).** The coarser fraction of the filter with respect to its own finer fraction must meet the retention criterion. If the material is broadly graded, segregation in handling and placement is more likely and internal stability can become a serious issue.
- **Retention function.** The filter must prevent the migration of particles from adjacent shell materials, or from the core. Thus, a fine filter must prevent the migration of finer-grained core materials, while a coarse filter must prevent any migration of the fine filter. The criterion linked to this function is defined depending on the base soil characteristics (base soil corresponds to the soil to be protected, e.g. for the fine filter, the base soil is the core material.)
- **Segregation avoidance.** Both fine and coarse filters must not segregate during construction. The processing, handling, stockpiling, re-excavation, dumping, spreading, or compaction must be carried out by minimizing segregation. The following table presents the criterion that links the minimum  $D_{10}$  of the material to the maximum  $D_{90}$ .

Minimum $D_{10}$ mm	Maximum $D_{90}$ mm
< 0.5	20
0.5-1.0	25
1.0-2.0	30
2.0-5.0	40
5.0-10	50
10-50	60

Table 34: Segregation criterion, (ICOLD 1994)

### **3.3.2 Specifications for Materials Grading**

Based on design criteria presented in the previous paragraph, materials grading is defined and presented below.

#### **3.3.2.1 Core Material**

The first and primary point of interest on core materials is the fine content. According to ASTM standards used by the Consultant, the fine content is defined by the percentage of materials with a grain size equal or below 0.08 mm.

The dam core structure consists of a coarse elements matrix, which provides the skeleton of the core, and ensures certain rigidity, required to avoid excessive settlement. The fine fraction is intended to fill the voids between coarse elements and ensure the watertightness properties of the core. That is why the fine fractions of core material are expected to completely fill the voids between coarse elements.

Such a requirement is to be tested in detail through a complete campaign of in-situ test and large-scale laboratory equipment in order to take into account the whole grading distribution of the core materials. The second point to be addressed is the segregation avoidance during placement of core material. The grading curve defined by HPI for core material specifies a fine content ranging from 13 % to 33 %. It is important to note that the specified grading curve of the Nurek dam core, which is a major reference in a similar context, shows a fine content ranging from 22 % to 57 %.

Without the present experimental evidence that low fine content is acceptable for the required performance of the core material, TEAS Consortium would recommend a higher fine content not lower than 20% (similar to the Nurek experience) and the following grading curve:

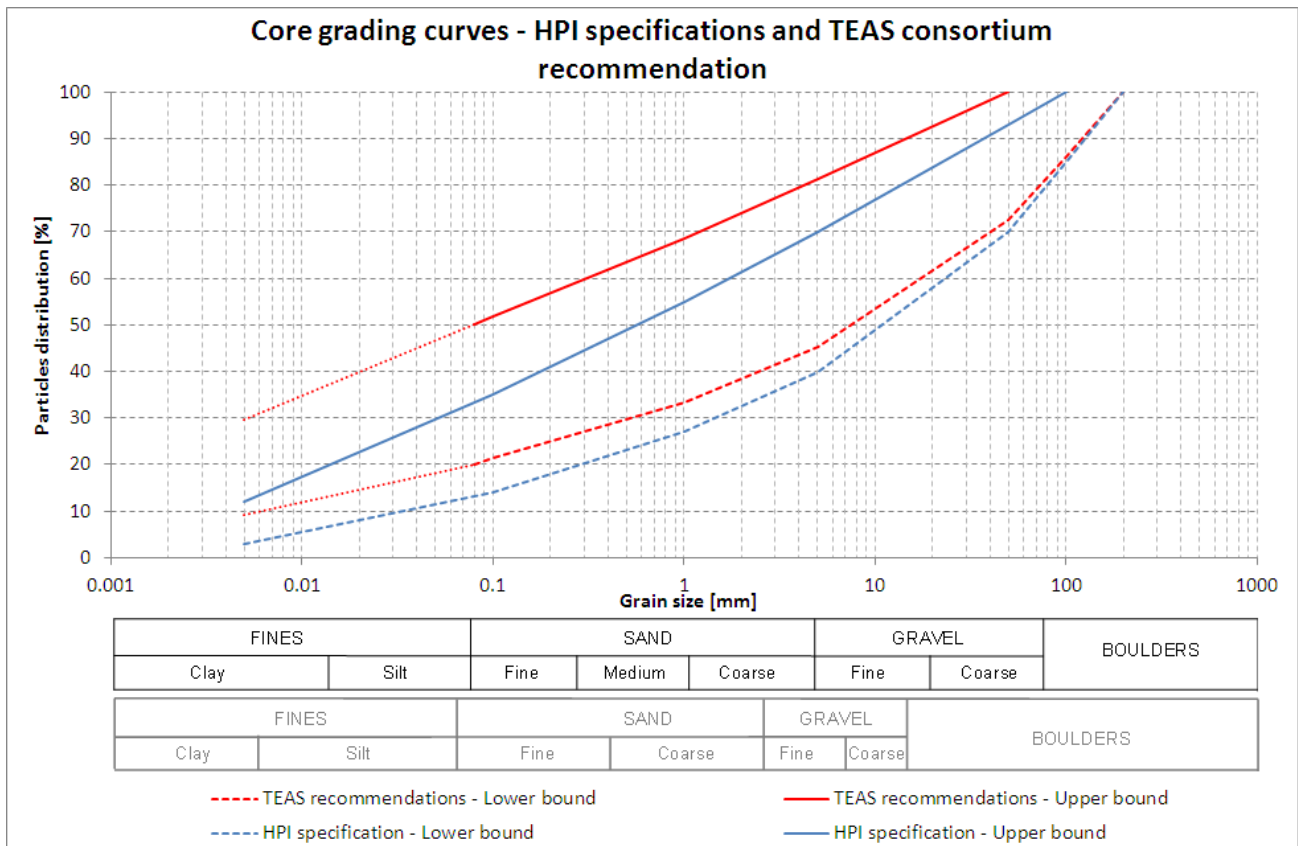

**Figure 14: Core Grading Curve**

Concerning core materials, a comprehensive analysis on the impact of fine content on watertightness is awaited in order to set the required fine content, and adapt the processes needed to meet these specifications. Based on its experience, the TEAS Consortium considered that a conservative approach is to be adopted for this Feasibility Study. Therefore, a mixing of borrow area 17 materials with fine materials was considered in the cost estimate in order to increase fine content, for all the material of the dam core. Fine materials have been identified in sufficient quantities from different sources.

It is important to note that the permeability tests on materials presenting large grading (and large particles) cannot be done in laboratory conditions because the size restrictions of the test devices mean that the samples are impoverished from an important part of coarser elements. This is why the Consultant insists on the necessity to carry out in-situ tests, especially for permeability estimates, in order to test the material as it will be placed in the dam, and for evidence, if this low fine content makes it possible to reach the required water-tightness to ensure long-term integrity of the core. These tests can be carried out during the detailed design stage, in the next phase of the studies.



Moisture content of borrow area 17 is also a point of concern, and moisture control has been taken into account in cost estimates by considering special storage conditions.

### 3.3.2.2 Filter Materials

Retention and segregation criteria help define the following grading curves to be met for filter materials:

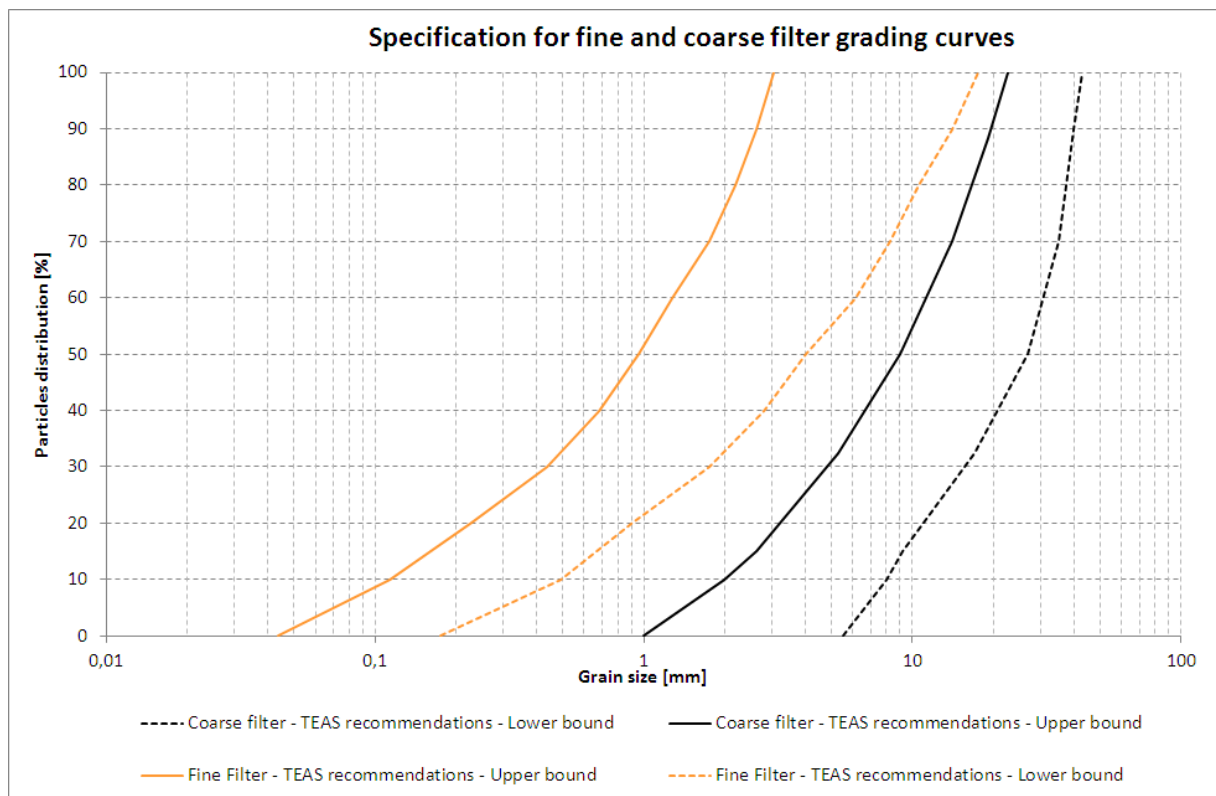

**Figure 15: Specifications for Fine and Coarse Filter Grading Curve**

The materials already extracted from the Lyabidora borrow area are the most adequate for use as filter material. The materials will be treated in order to meet the grading specifications following classical crushing and screening processes. It is noted that the Lyabidora borrow area will not be further exploited and the remaining material quantities can easily be found in borrow area 15.

Tests are to be undertaken, defining and confirming the following parameters in priority:

- Permeability tests,
- Frost resistance,

- Compaction tests,
- Shear strength / Compressive strength.

### 3.3.2.3 Shoulder Materials

Shoulder material grading curve is defined based on design criteria as follows:

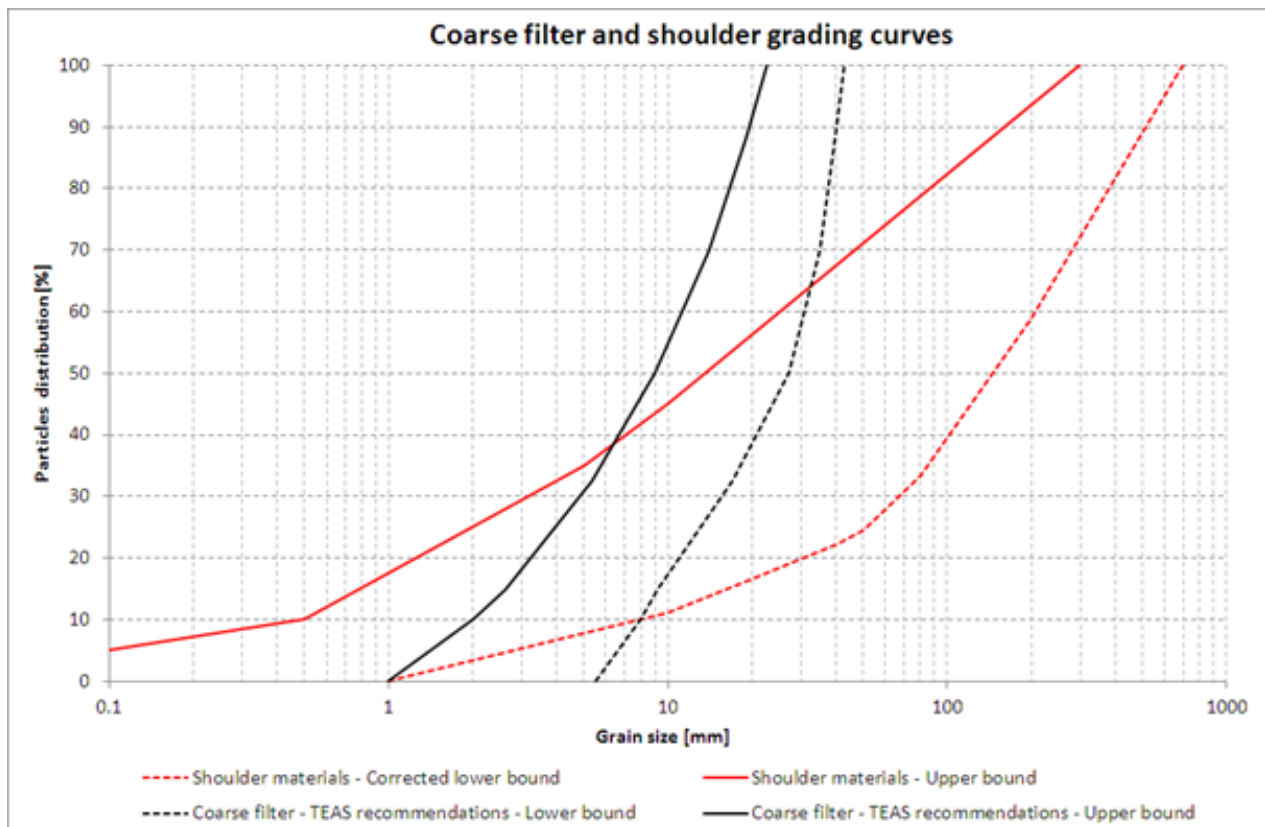

**Figure 16: Coarse Filter and Shoulder Grading Curves**

For the shoulder area in direct contact with the coarse filter, a limitation of the large boulders can be recommended as a particular placement feature. A first rough approach would be to consider that, during the placement process, the largest boulders (>500 mm) are removed mechanically from the first 10-15 meters in contact with the coarse filter layer, and distributed in the rest of the shoulder layer. The details of this procedure are to be determined in further studies of the project.

According to the results of previous studies and available information on materials characteristics, alluvium materials from borrow areas 15 seem in accordance with grading specifications, and do not present major issues. The laboratory and in-situ testing shall follow international standards.

Some large-scale tests may be conducted concerning strength characteristics as the materials contain an important amount of large particles.

The following tests are to be carried out in priority:

- Frost resistance tests,
- Compaction tests,
- Tri-axial tests / large-scale shearing devices.

### 3.3.2.4 Rockfill Materials

Rockfill materials grading is defined as follow:

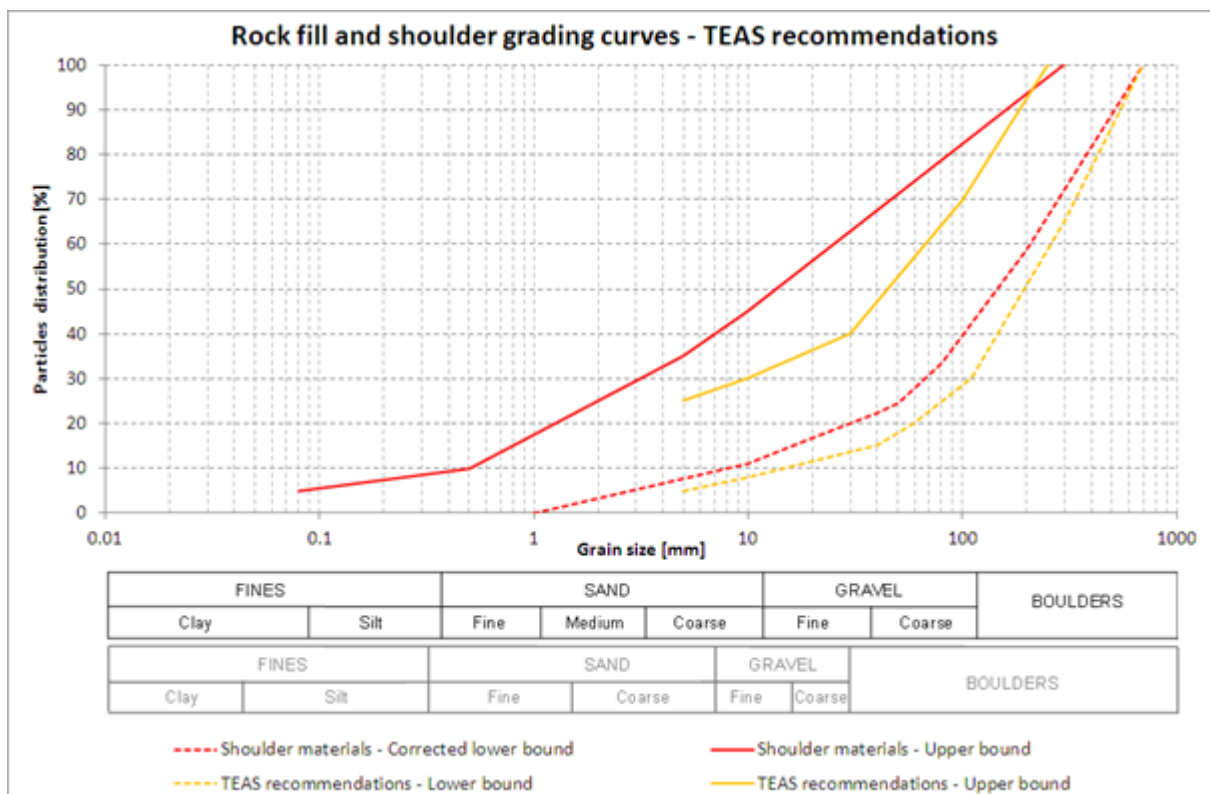

**Figure 17: Rockfill and Shoulder Grading Curves**

The rockfill function is to stabilize the dam structure, but should also allow the reservoir level to vary (increase and decrease) without keeping a high pore pressure. For this feature, the material's permeability should be adapted. The minimum material size is limited to 5 mm, in accordance with this purpose.

ICOLD – CIGB (ICOLD - CIGB , 1993) recommends for rockfill to limit the finer parts to sand fractions and avoid fines particles. The recommended sand content is a maximum of 30-35%, in accordance with the current grading curve.

Rock materials are involved in the construction of the Rogun project as shell material for the upstream and downstream faces of the dam, and as fill material for the upper parts of shoulders and riprap slope protection. The tests carried out so far on the materials from quarry 26 provide a preliminary assessment of the rock quality, but carrying out a campaign of tests during the next steps of the Rogun project studies is strongly recommended in order to define more precisely the following properties:

- Compressive resistance,
- Water absorption,
- Frost resistance and water resistance,
- Shear strength / compressive strength.

#### 3.3.2.5 Riprap Materials

The riprap definition is subjected to a particular design procedure. The upstream embankment of the dam is subjected to the aggressive dynamic effect of waves, and to the effects of freezing and of ice. The riprap is a protective layer of large rock materials designed to resist such climatic impacts. The dimensions of riprap materials depend on the heights of waves on site and the fetch length. The design wave height depends on wind velocity.

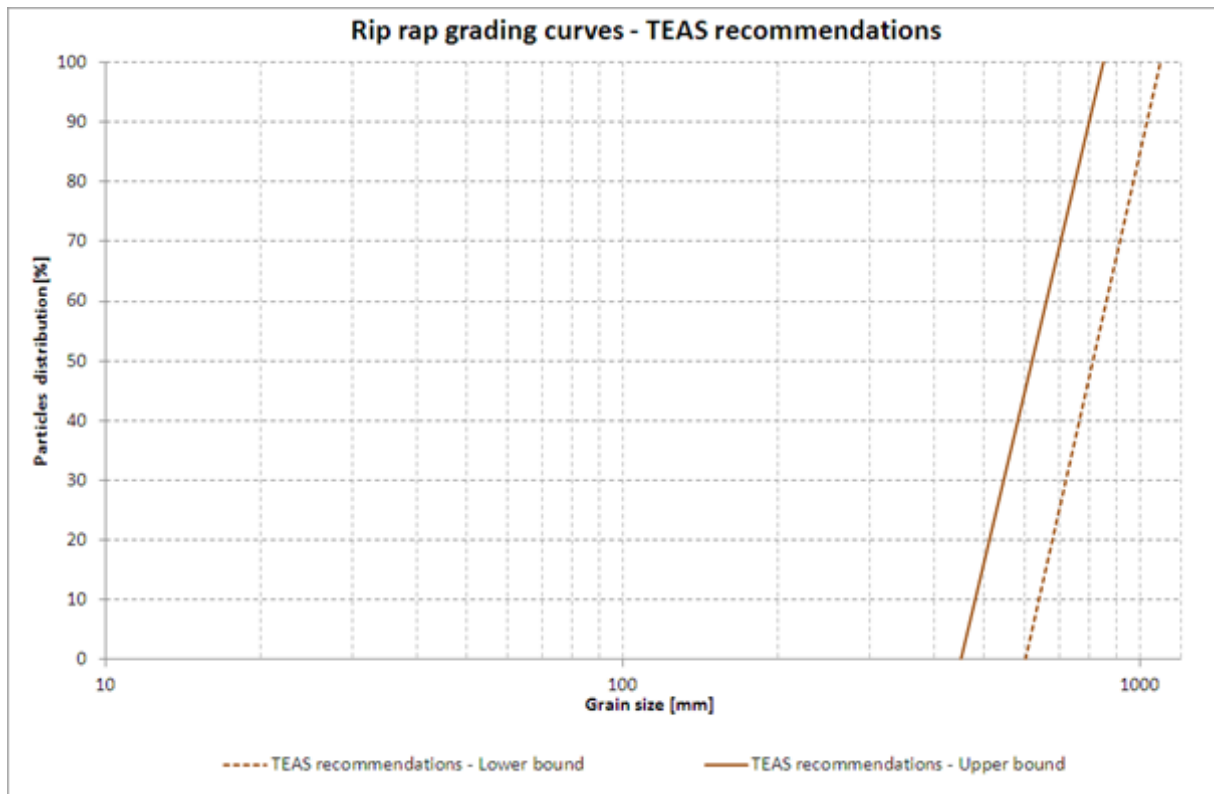

Figure 18: Riprap grading curves

#### 4 CONCLUSIONS AND RECOMMENDATIONS

The volumes needed for the dam are available in quarries / borrow areas and associated stockpiles. As a matter of priority, the filters materials are to be used from available stockpiles after extraction from the borrow area of Lyabidora. However, the volumes of this stockpile are insufficient, and the missing volumes are to be extracted from borrow area 15, and processed in order to meet the specifications for filters. Specific care shall be given to timely extraction of material from BA 15, as this borrow area will be flooded during the early stages of construction.

The necessary quantities of concrete aggregates are covered by the excess materials from borrow area 15, which present a large grading adapted to concrete aggregate purposes, and by considering a specific treatment and selection of suitable materials.

With regard to core materials, a comprehensive analysis on the impact of fine content on watertightness is awaited in order to set the required fine content, and adapt the processes needed to meet these specifications. Based on its experience, the TEAS Consortium adopted a conservative approach for this Study.

Therefore, a mixing of borrow area 17 materials with fine materials has been considered in the cost estimate in order to increase the fine content for the whole material of the dam core. Fine materials have been identified in sufficient quantities from different sources.

The moisture content of borrow area 17 requires reduction, and moisture control has been taken into account in cost estimates, by considering special storage conditions.

The international standards for testing and specifications are strongly recommended for understanding and facilitating international tendering. In any case, the Russian standards are not questioned, but in the case of international tender for the Rogun project construction, international contractor's comprehension would be helped, especially for cost and risk estimates at bidding.

Studies of construction materials and associated studies revealed the need for a comprehensive campaign of testing of all materials in both laboratory and in-situ conditions during the next design stage. The best time to carry out these tests is before tendering for the reasons cited above. The cost of such a campaign remains low compared to the total cost of the project, and may represent a very positive input for the further steps of the proposed Rogun project.

## **CHAPTER 3.3: APPENDIX 2 – REPORT ON EMBANKMENT DAM STABILITY**

### **1 INTRODUCTION**

This chapter addresses the technical assessment of Rogun dam stability. It includes a brief review of documents produced by HPI about the dam stability in 2009 and made available to the Consultant by the Client. It also includes the Consultant own assessment of the stability of the dam. It is to be noted that the Consultant chose to perform the stability analysis on the same typical cross section used in the calculation by HPI which matches the highest dam alternative (FSL 1290 masl).

The main objective of this study is to understand the dam behavior during earthquake and to evaluate the permanent displacement likely to occur during an extreme seismic event. This was carried out on the highest alternative layout proposed by HPI and on different cross sections with different heights.

The results of this assessment are then used to derive the Consultant's own typical cross sections for the three different dam alternatives.

Once the most suitable alternative is selected, it is recommended to carry out further analysis considering all peculiarities of the dam, including 3D analysis.

### **2 REVIEW OF HPI STUDY**

In general, the review of the documents made available to the Consultant shows that many elements of the HPI analysis, especially the material dynamic properties, are unclear.

Nevertheless, it is to be noted that:

- The stability analysis by static equilibrium showed that the dam stability in static conditions is ensured;
- The results of the static analysis with the 2D finite element model are unclear but the check calculation made by the Consultant showed acceptable results;

- The level of seismic loading considered by HPI (PGA of 0.55g) is lower than the one recommended by the Consultant (PGA of 0.71g);

All of the above lead the Consultant to make its own independent assessment of the dam stability.

### 3 STATIC ANALYSIS PERFORMED BY THE CONSULTANT

#### 3.1 Geometry

The geometry used in the static stability analysis is several cross-section of the design study by HPI in their 2009 calculation notes. The typical cross section is presented in the next figure.

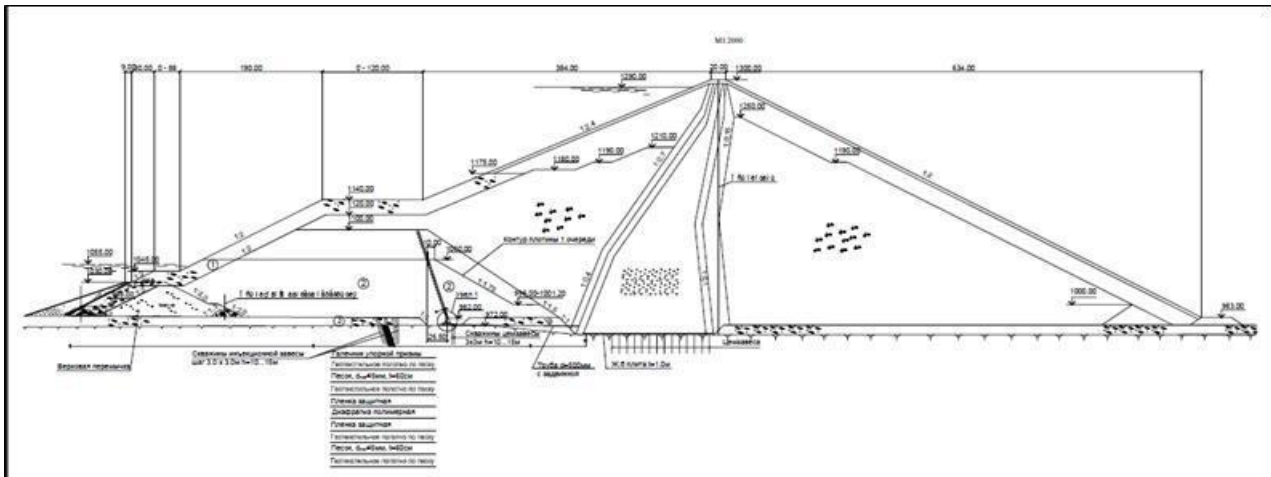

**Figure 19 : Calculation cross section (Dam stability 3D modelling, Hydroproject, 2009)**

As the valley is S-shaped, the typical cross section as presented in the previous figure is not a real cross section. Therefore, several “real” cross sections are studied. They are indicated on the next figure.



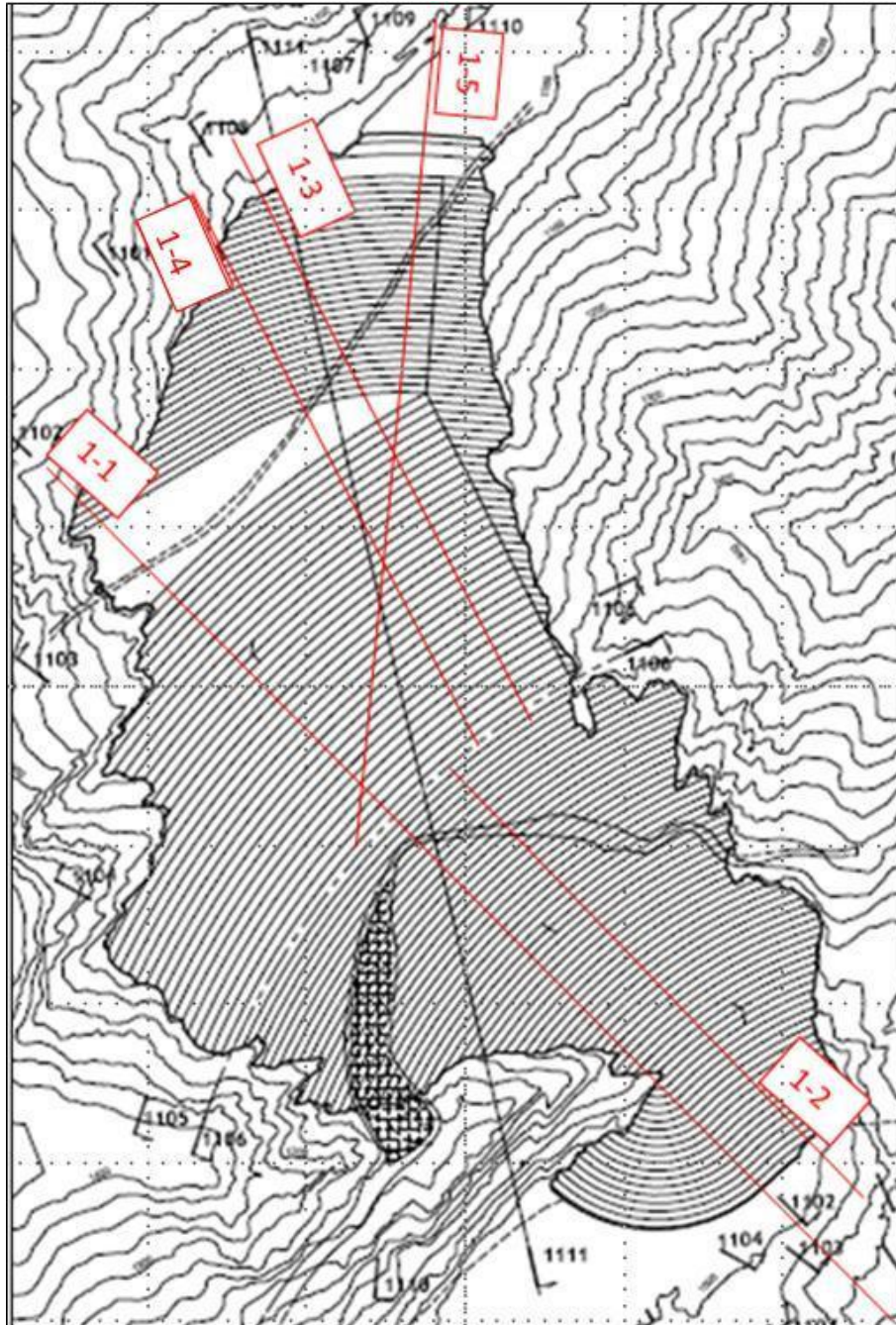

**Figure 20 : Layout of the cross-sections**

Cross section 1-1 is the one studied by HPI. Cross section 1-2 presents a full downstream slope: full height and full length. Cross-sections 1-3 and 1-4 are the full upstream slope with a two different width for the riser. And cross section 1-5 is normal to the stage 1 slope. This one aims at assess the safety factor of the Stage 1 slope that is stiffer than the general upstream slope of the dam (1:2 for the Stage 1 and 1:2.4 for the dam).

## 3.2 Results

The next table the minimum safety factors that have been found for all calculation made: all loading conditions, and all cross sections. The sign – means that this calculation is not available because this load condition on this cross section has no meaning.

	Loading condition	Slope	1-1	1-2	1-3	1-4	1-5	HPI results
1	End of construction	Upstream	2.37	-	2.26	2.39	2.00	-
		Downstream	1.87	1.85	-	-	-	-
2	Normal condition - Water level at FSL	Upstream	2.54	-	2.37	2.49	1.94	2.06
		Downstream	1.87	1.84	-	-	-	1.64
3	Normal condition – Water level at MOL	Upstream	2.16	-	2.12	2.15	2.18	-
4	Rapid drawdown from FSL to MOL	Upstream	2.08	-	2.02	2.14		-

**Table 35 : Static analysis – Results**

For all loading condition, the static design criteria are respected. HPI results are lower, which can be explained by the calculation method that is different: Fellenius vs. Morgenstern-Price.

## 4 SEISMIC ANALYSIS

### 4.1 Design criteria

For the extreme seismic load case (MCE, Most Credible Earthquake), the dynamic behavior of the dam is studied and permanent displacements are then assessed. The vertical crest settlements are taken in to account on the freeboard design: the settlements likely to occur during an earthquake have to be lower than the available freeboard between the reservoir level and the dam crest.

The horizontal displacement shall be acceptable for the filters: their width shall be larger than the horizontal displacement during the MCE. The displacements calculated in this study will determine the filters width.

## 4.2 Geometry

The following cross sections are chosen to be studied in the seismic analysis:

- Cross section 2-1 is the section along the river bed;
- Cross section 2-2 is a “real” section along the right bank
- Cross section 2-3 is a “real” section along the left bank.

A plan view of these sections is presented in the figure below. It is worth to notice that section 2-1 represents the maximum dam section area. The two others are “real” sections on each bank.



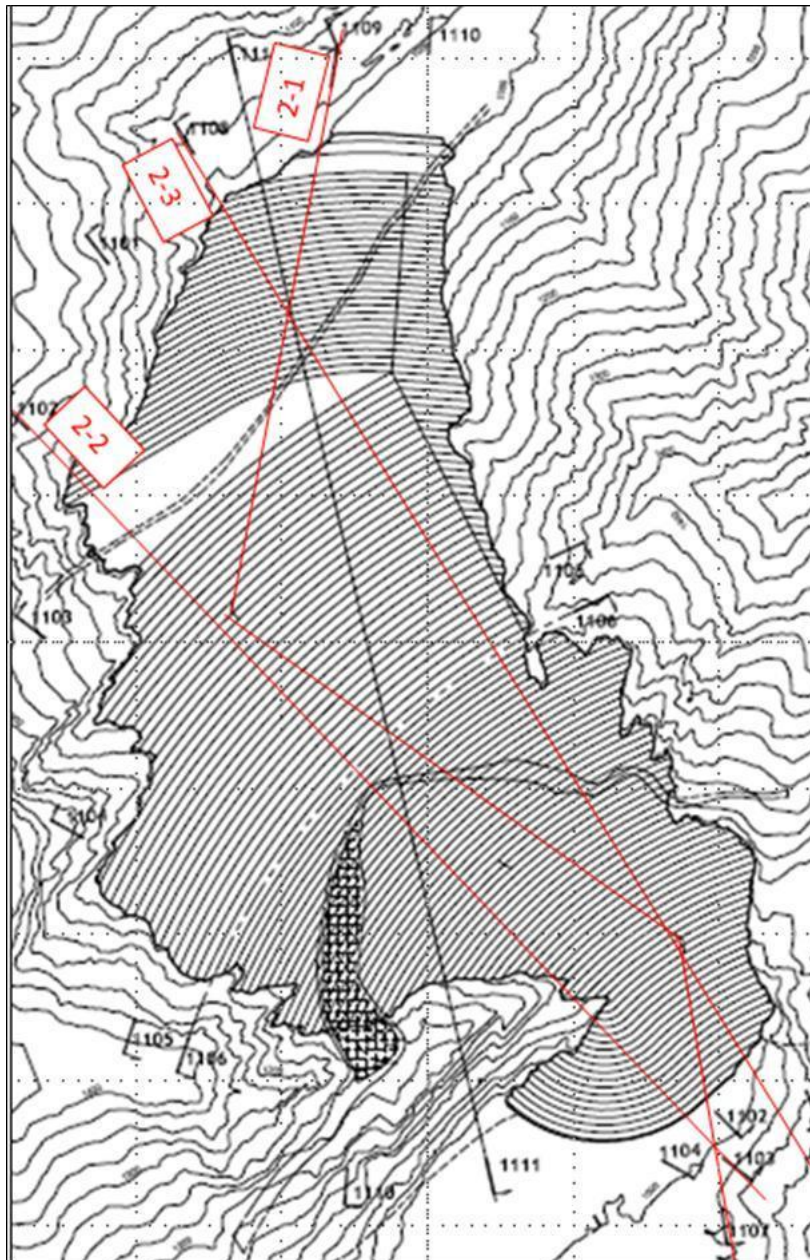

Figure 21 : Cross sections for dynamic analysis - Plan view

### 4.3 Design earthquake characteristics

As stated in the design criteria, the stability analysis during seismic loading are studied for the MCE (Maximum Credible Earthquake).

The Peak Ground Acceleration of the earthquake is presented in the following table.

Earthquake	PGA
MCE	0.71g

**Table 36: Design earthquake PGA**

The figure below shows the spectra acceleration of five accelerograms used to represent the input ground section. It can be seen that the range of fundamental period is 0.1-0.5 s.

The spectrum used as excitation signal in the calculation is the Spectrum 1 (black line).

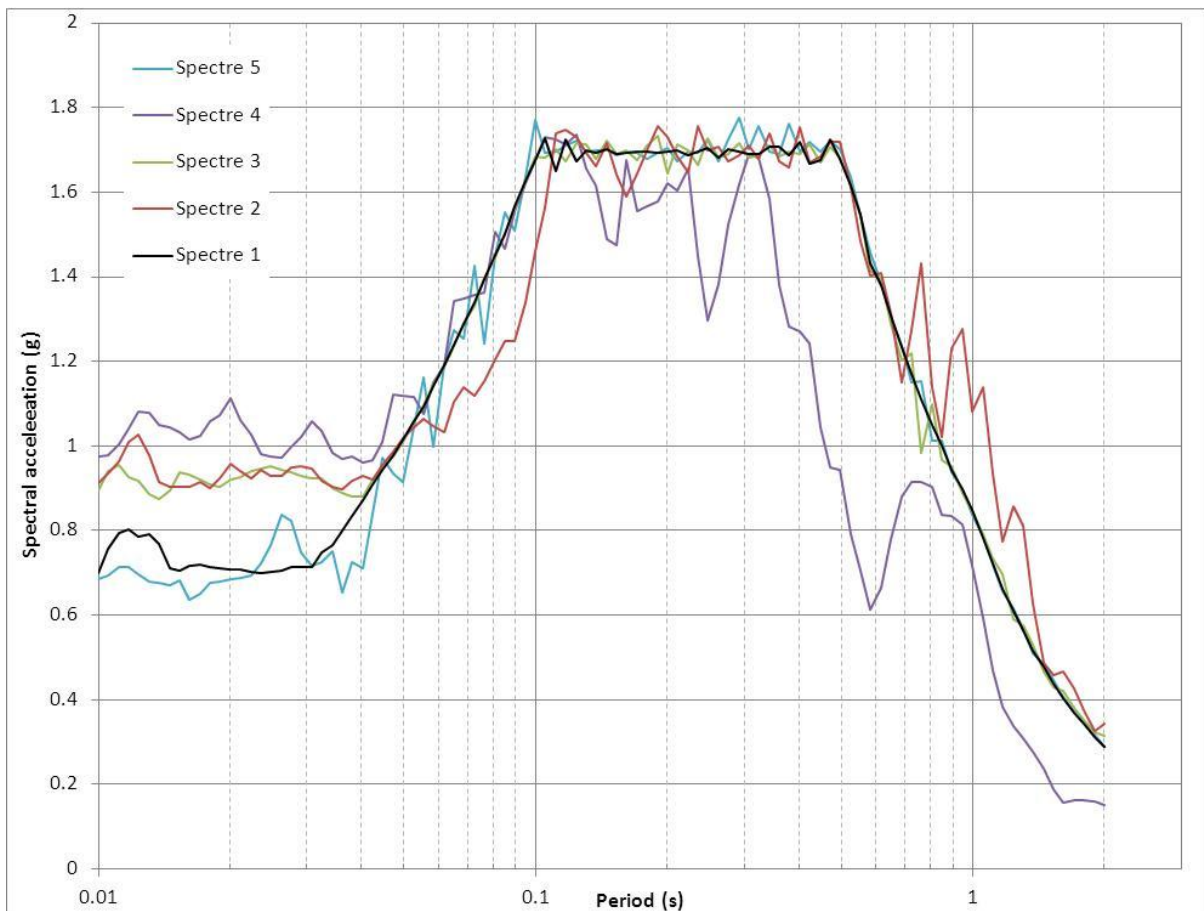

**Figure 22 : MCE spectral acceleration distribution (damping ratio 5%)**

#### 4.4 Dynamic deformation parameters

Seismic response analyses have been performed assuming a visco-elastic stress-strain behavior of the materials. In addition, the equivalent linear approach iteratively calculates the elastic modulus and damping ratio of the material until they are compatible with the computed shear strains.

In a conservative approach, the damping ratio and the elastic modulus reduction function are defined using Ishibashi and Zang (1993) functions.

## 4.5 Dynamic dam behavior

### 4.5.1 Dynamic elastic behavior without the reservoir

As a first simplified approach, the fundamental frequencies of the dam body (section 2-1, 2-2 and 2-3) are estimated using the finite element code by MIDAS software and assuming an elastic linear behavior of the material and without the reservoir.

The first 30 natural frequencies have been calculated in order to warranty that at least 90% of the total mass is mobilized.

The following tables summarize the main natural frequencies and the total mass mobilized.

In order to take into account the variation of modulus as a function of the confining stress, the dam body is divided in various zones in accordance to their mean confining stress.

Eigen value Analysis				Modal Mass participation (%)	
Mode No	Frequency	Frequency	Period	Horizontal - X	Vertical - Y
	(rad/sec)	(cycle/sec)	(sec)	MASS(%)	MASS(%)
1	5.16	0.82	1.22	58.93	0.03
2	7.64	1.22	0.82	0.01	26.31
5	10.37	1.65	0.61	15.94	0
6	11.73	1.87	0.54	0.02	16.56

**Table 37: Principal natural frequencies of section 2-1**

Eigen value Analysis				Modal Mass participation (%)	
Mode No	Frequency	Frequency	Period	Horizontal - X	Vertical - Y
	(rad/sec)	(cycle/sec)	(sec)	MASS(%)	MASS(%)
1	5.79	0.92	1.09	59.58	0.04
2	8.14	1.30	0.77	0.15	36.66
5	12.12	1.93	0.52	10.24	2.4
6	12.82	2.04	0.49	1.28	17.89

**Table 38 : Principal natural frequencies of section 2-2**

Eigen value Analysis				Modal Mass participation (%)	
Mode No	Frequency	Frequency	Period	TRAN-X	TRAN-Y
	(rad/sec)	(cycle/sec)	(sec)	MASS(%)	MASS(%)
1	8.01	1.27	0.78	36.19	0.15
2	11.20	1.78	0.56	0.03	15.22
3	12.50	1.99	0.50	24.15	0.33
8	17.49	2.78	0.36	0.31	17.06
10	18.20	2.90	0.35	3.52	13.65

**Table 39 : Principal natural frequencies of section 2-3**

The first natural period of section 2-1 is 1.22 s, 1.09 s for section 2-2 and 0.78 s for section 2-3.

The first natural period of the dam is outside of the most amplified range of period of the seism. Nevertheless, the third period and the following get closer.

#### **4.5.2 Equivalent linear analysis**

The linear equivalent analysis calculates the dynamic response of the dam to the earthquake. This is a temporal, equivalent linear, two-dimensional finite element computation performed with the Quake software.

The Quake model is constructed with the mesh geometry and the static stress field obtained by a stress analysis. The effective stresses are applied to estimate the maximum shear modulus ( $G_{max}$ ).

This analysis takes into account the elastic response, and also the soil strength softening with the strain, but it does not consider a plastic behavior of the material. The permanent deformations are evaluated afterwards according to the Newmark method.

The three section presented earlier are studied (2-1, 2-2, 2-3) with a reservoir at FSL. The Section 2-1 is also studied with an empty reservoir.

##### **4.5.2.1 Fundamental period**

The fundamental period of the dam body at section 2-1, 2-2 and 2-3 are estimated using the equivalent-linear Quake code by computing the horizontal harmonic response of the dam of a point located on the dam crest.

The horizontal harmonic response of the dam is calculated as the ratio between the Fast Fourier Transformation (FFT) of the crest response to the MCE ground motion.

It has to be highlighted that with a nonlinear or equivalent linear behavior of the material, the fundamental frequencies depend on the magnitude of the ground motion. Indeed, the earthquake amplitude reduces the shear modulus of the material, as a consequence the fundamental frequency found should be lower than the one found with the elastic-linear computation.

It should also be noted that the reservoir effect is taken into account in this computation.

The first fundamental frequencies are reported in the next table.

As expected the first fundamental frequencies are slightly lower (periods are slightly higher) than the one found with the elastic analysis.

Section 2-2 and Section 2-1 have very close fundamental period and amplification, indeed the dam height under the crest is the same on these two sections. The fundamental period of section 2-3 is lower which is expected as its height is also much lower than the two other sections.

The section 2-3 fundamental period is closer to the high amplification period range of the MCE spectra than the two others

	Section 2-1	Section 2-2	Section 2-3
First fundamental frequency (Hz)	0.70	0.77	1.14
First fundamental period (s)	1.44	1.30	0.87

**Table 40 : Equivalent linear results - Dam fundamental frequency**

#### 4.5.2.2 Seismic response analysis

Here, the results are presented in terms of peak horizontal acceleration, effective peak shear stress and relatives displacements.



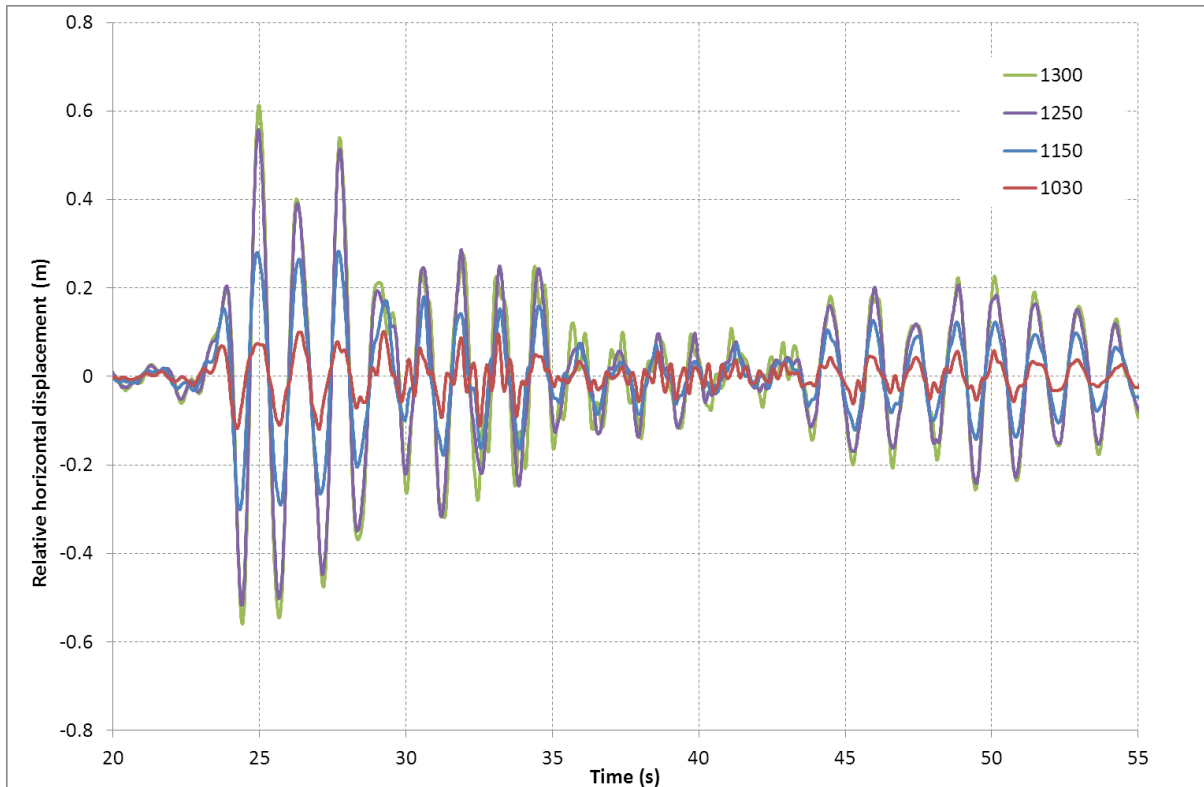

**Figure 23 : Section 2-1, Relative displacement at several elevations**

This figure shows the time domain relative displacement of the dam thanks to several points located at various elevation of the central line of the dam body. It can be clearly seen that the peak takes place at the crest with a period in agreement with the first natural period calculated earlier.

The following comments can be made about the results presented:

- Peak horizontal acceleration at the crest vary from 2.5g for section 2-3 to 3.76g for section 2-2.
- The large riserm above the Stage1 dam is also an area of maximum peak acceleration. There , the peak acceleration vary from 3.3 to 4.3 g depending on the section.
- The peak horizontal acceleration contour lines tend to follow the upstream and downstream slope of the dam, and it decreases quickly within the dam.
- Finally, the downstream toe of section 2-2 presents important horizontal acceleration: up to 3.7g.
- In the three section, the maximum peak effective shear strain is located 50 m under the crest and vary from 0.006 in section 2-3 to 0.0086 in section 2-2.

The seismic response analysis shows that the largest strains and largest crest acceleration are produced at section 2-2.

The peak horizontal acceleration contour shows where are the highest values: at the dam crest and at the larg risberm above the Stage 1 dam. The slip circle studied in the Newmark analysis should cross these area of high acceleration to found the most critical permanent displacement.

#### 4.6 Assessment of permanent displacements

Three methods have been used to assess the non-reversible deformation of the dam: the empirical method of Swaisgood, the analytical methods of Makdisi and Seed, and Newmark. The next tables compare the values found for vertical displacement (settlement) and horizontal displacements.

Method	Section	Settlement calculated (m)
Swaisgood	-	4.2
Makdisi and Seed	2-1	5.7
	2-2	6.1
	2-3	1.5
Newmark	2-1	5.3
	2-2	4.2
	2-3	6.0

**Table 41 : Results of Seismic analysis – Settlement**

The various method applied give coherent results in term of crest settlement: between 1.5 and 6.1 m, with an average value of 4.7 m.

Method	Section	Horizontal permanent displacement calculated (m)
Swaisgood	-	-
Makdisi and Seed	2-1	8.0
	2-2	8.6
	2-3	2.2
Newmark	2-1	9.0
	2-2	7.8
	2-3	9.1

**Table 42 : Results of Seismic analysis – Horizontal permanent displacement**

The various methods applied give coherent results in terms of horizontal permanent displacement: between 2.2 and 9.1 m, with an average value of 7.5 m. One value is much lower than the others: section 2-3 with Makdisi and Seed method. The various cross sections give comparable results.

These values of permanent displacements are important but are consistent with the unprecedented size of the dam: it represents between 0.5% and 2.7% of the dam height. It is to be reminded that for the MCE, damages can be accepted as long as no uncontrolled release of water occurs.

Therefore:

- the range of settlement for the MCE is acceptable if at least a 6 m freeboard is provided.
- The range of horizontal displacements for the MCE is acceptable provided that filters are at least 10 m thick.

Repair works are to be planned after such high seismic event.

## 5 STAGE 1 STABILITY ANALYSIS

### 5.1 Geometry

As for the final dam, the Stage 1 dam geometry considered is the one proposed by HPI.

Indeed, the geometry and especially the slopes of the Stage 1 dam are imposed by topographical and site constraints. These constraints are detailed in the dam design report: final dam core footprint, diversion tunnel intakes and Ionaksh fault.

This paragraph mainly aims at verifying that the 1.7H/1V downstream slope and 2H/1V upstream slope verify the design criteria. It aims also to check the stability of the wedge shaped by the watertight membrane (which is replaced by a bituminous core in the Consultant design).

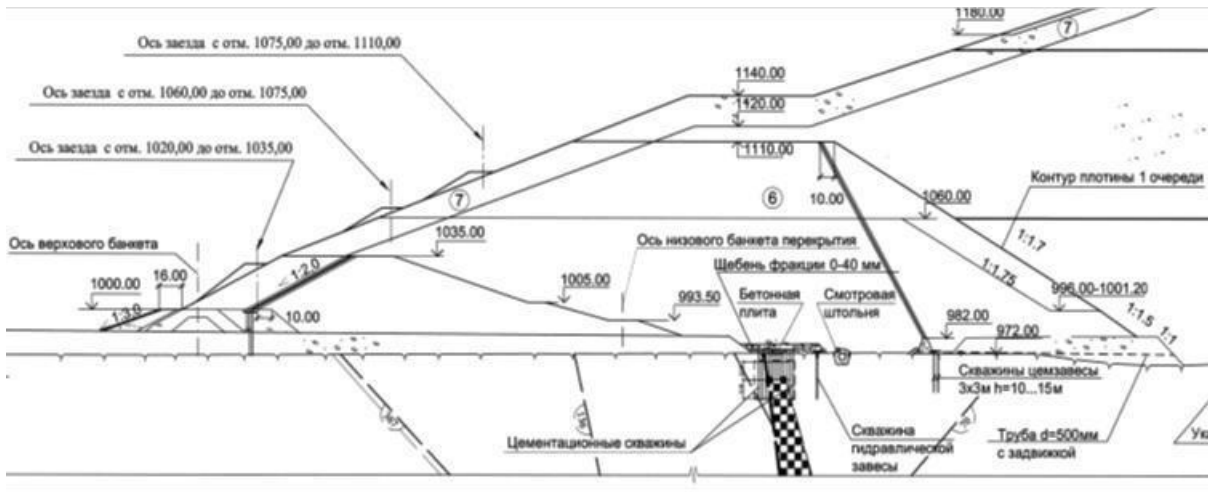

Figure 24 : Stage 1 dam geometry

## 5.2 Material properties

The Stage 1 dam is made of the same gravel material than the final dam.

The dam-foundation friction angle is considered as the lowest of the dam material internal friction angle and the foundation internal friction angle, ie 39° under the gravel shell.

## 5.3 Calculation method

As it is a step of construction, the stage 1 stability is only verified thanks to a 2D slope stability analysis.

	Loading condition	Minimum safety factor
1	End of construction	1.3
2	Normal condition - Water level at FSL	1.5

Table 43 : Design criteria for the Stage 1 dam

The wedge shaped by the watertight membrane is pushed by the water pressure acting on the membrane and the friction is mobilized on the horizontal surface. The stability of the wedge is assessed considering this wedge as rigid and by force equilibrium as illustrated in the next figure.

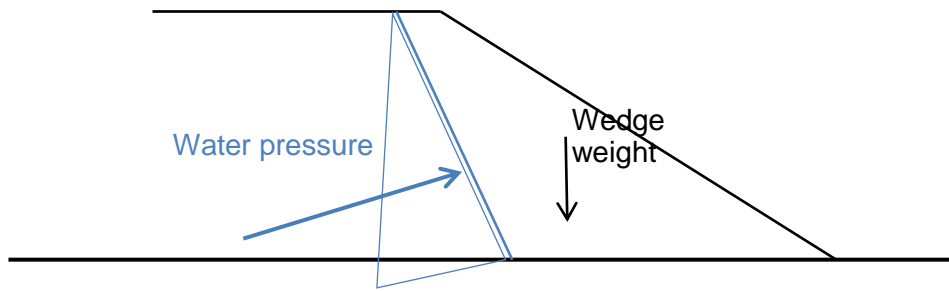

Concerning seismic event, MCE defined earlier is adapted to a stand-alone project. Here, the Stage 1 dam is a construction step that lasts less than 10 years. Two approaches are being used to assess the Stage 1 dam sensitivity to earthquake:

- The evaluation of the irreversible deformation thanks the Swaisgood formula;
- The research of the maximal horizontal acceleration that still respect a safety factor of 1.

## 5.4 Results

The critical safety factors for each load case are presented in the next table.

	Loading condition	Slope	TEAS results	HPI results
1	End of construction	Upstream	2.09	-
		Downstream	1.72	-
2	Normal condition - Water level at FSL	Upstream	2.20	-
		Downstream	1.70	1.56
		Wedge	2.53	-

**Table 44 : Stage 1 dam stability analysis – Results**

The next figures show the critical slip surface for each cross section and loading conditions.

The plastic deformation causes by an earthquake are evaluated thanks to the Swaisgood formula and are presented in the next table.

Earthquake	MCE
Crest settlement due to the earthquake (Swaisgood) (m)	1.10

**Table 45: Stage 1 dam crest settlement during earthquake - Swaisgood formula**

## 5.5 Conclusion about Stage 1 dam stability

The Stage 1 dam upstream and downstream slopes are sufficient to ensure the stability of this construction phase.

As the cofferdam has the same material and upstream slope, softer downstream slope, and lower height than this Stage 1 configuration, it can be stated that the cofferdam stability is also secured.

## 6 CONCLUSION AND RECOMMENDATIONS

This report includes a brief review of the existing documentation made available by the Client to the Consultant, regarding stability analysis carried out by HPI. From the calculated cross section used by HPI, the Consultant carried out its own assessment based on which a typical cross section has been defined for the highest alternative.

The Rogun dam stability is ruled by the seismic load case. During MCE (Maximum Credible Earthquake), large irreversible deformation will occur: crest settlement and horizontal shear movement. Therefore, the analysis performed by the Consultant aims mainly at assessing the permanent displacements likely to occur during an extreme earthquake (MCE).

The study shows that the range of permanent displacement is 2-9 m horizontally and 1.5-6 m vertically.

The analysis also shows that during earthquake for all sections, the upper 50 m of the dam are the most critical in terms of acceleration and shear strain.

Based on these results the Consultant considers the following design features:

- Dam slopes should be kept as designed by HPI: 2H/1V downstream and 2.4H/1V upstream above the large berm level and 2H/1V below. Indeed, these slopes have been found sufficient to ensure the stability of the dam.

- Given the range of horizontal displacement found, filters and transitions thickness should be at least 10 m to ensure its continuity even in the case of a large earthquake.
- The freeboard should be at least 6 m to accommodate the settlement found likely to occur during a large earthquake to avoid dam overtopping.
- Special care should be given to the upper part of the dam (top 50 m): to limit mass sliding the Consultant prefers to set material such as rockfill that have a higher friction angle than the alluvium.

Three different cross sections of the dam have been studied: one in the river bed, one in the right bank and one on the left bank. The corresponding dam height ranges from 160 m to 335 m. This allows studying the sensitivity of the results with respect to the dam height. It can be seen that even if the dynamic behavior is slightly different from one dam height to another, the overall permanent displacement are in the same range of magnitude.

Therefore it is considered that, for alternatives comparison purposes, the same conclusions and recommendations are to be applied to the three dam alternatives and are used to derive the corresponding typical dam cross section.

Provided that the design features stated above are introduced in the various dam alternatives, the safety of the Rogun dam is ensured under static and seismic conditions.

Additional design measures, such as strengthening devices, are not necessary at this stage. However in further stages of the Project development, with the results of the three-dimensional seismic behavior analysis, such specific features shall be analyzed again. It should be outlined also that such reinforcement was not finally retained by HPI for Rogun, after the results of the more detailed calculations they performed.

Further study and optimization should be performed at later stages to determine precisely the dam behavior under the various loads, taking into account:

- The 3D geometry of the dam including the S-shaped valley and the very steep banks that tend to create arch effect and stress transfer to the banks;
- The elasto-plastic non-linear behavior of the material by using the advanced cyclic model such as hardening small strain model. It is worth noting that using the elasto-plastic non-

linear analysis determines directly the permanent displacement as well as the excess pore pressure generating during the earthquake in the core.



## **CHAPTER 3.3: APPENDIX 3 – FLOOD MANAGEMENT DURING CONSTRUCTION**

### **1 INTRODUCTION**

This part of the Phase II report deals with the flood management during construction of Rogun dam as defined by TEAS Consultant. Firstly, the scheme for flood diversion during construction proposed by HPI has been assessed in the light of the design criteria laid down by TEAS Consultant. This has led to modifications in the overall scheme that are presented in this report for the three proposed alternatives.

### **2 DESIGN CRITERIA**

#### **2.1 Input data**

This analysis has been carried out based on the results of the probabilistic analysis of the floods carried out in the hydrology Chapter 2.5 in terms of daily and peak discharges for different return periods. The hydrograph taken into account is the one established for the PMF and 10000 years return period flood and proportionally reduced for smaller floods.

Different Discharge / Water level measurements at specific gauging stations have been collected and analyzed to derive rating curves used in the determination of cofferdams elevations.

#### **2.2 Construction floods preliminary screening**

As per common practice, the construction flood analysis has been carried out by screening out a large range of acceptable probability of exceedance and return periods to choose for a given period of exposure, the relevant discharge for which the structure should be protected against. This is reflected in the following recapitulative charts, used for appropriate decision making among the pre-selected values (ellipses in the charts):

**Design Discharge for Flood Management during Construction**  
as a function of Probability of Failure and Period of Exposure

Probability of exceedance	Period of exposure – FSL= 1290 masl					
	CD: 1 years		S1: 4 years		MD: 6 years	
	MPR (yr)	Daily discharge	MPR (yr)	Daily discharge	MPR (yr)	Daily discharge
1/500	500	4 500	2000	5 000	3000	5 200
1/200	200	4 100	800	4 700	1200	4 800
1/100	100	3 850	400	4 400	600	4 550
1/50	50	3 550	200	4 100	300	4 300
1/20	20	3 200	80	3 750	120	3 900
1/10	10	2 900	40	3 450	60	3 600

MPR : Mean Period of Return.

CD : cofferdam; S1 : Stage-1 dam; MD: remaining of the main dam

**Table 46 : Design Floods. Ranges to be explored (FSL=1290 masl)**

**Design Discharge for Flood Management during Construction**  
as a function of Probability of Failure and Period of Exposure

Probability of exceedance	Period of exposure – FSL= 1255 masl					
	CD: 1 years		S1: 3 years		MD: 5 years	
	MPR (yr)	Daily discharge	MPR (yr)	Daily discharge	MPR (yr)	Daily discharge
1/500	500	4 500	1500	4 900	2500	5 100
1/200	200	4 100	600	4 550	1000	4 750
1/100	100	3 850	300	4 300	500	4 500
1/50	50	3 550	150	4 000	250	4 200
1/20	20	3 200	60	3 600	100	3 850
1/10	10	2 900	30	3 350	50	3 550

MPR : Mean Period of Return.

CD : cofferdam; S1 : Stage-1 dam; MD: remaining of the main dam

**Table 47: Design Floods. Ranges to be explored (FSL=1255 masl)**

**Design Discharge for Flood Management during Construction**  
as a function of Probability of Failure and Period of Exposure

Probability of exceedance	Period of exposure – FSL= 1220 masl					
	CD: 1 years		S1: 2 years		MD: 3 years	
	MPR (yr)	Daily discharge	MPR (yr)	Daily discharge	MPR (yr)	Daily discharge
1/500	500	4 500	1000	4 750	1500	4 900
1/200	200	4 100	400	4 400	600	4 550
1/100	100	3 850	200	4 100	300	4 300
1/50	50	3 550	100	3 850	150	4 000
1/20	20	3 200	40	3 450	60	3 600
1/10	10	2 900	20	3 200	30	3 350

MPR : Mean Period of Return.

CD : cofferdam; S1 : Stage-1 dam; MD: remaining of the main dam

**Table 48 : Design Floods. Ranges to be explored (FSL=1220 masl)**

In the subsequent phase of the analysis, these ranges of protection level have been studied to assess the sensitivity of the structures design (and their costs) with respect to the protection level.

### 2.3 Flood management

Turbines discharge capacities have not been taken into account in the flood discharge system overall capacity.

For the Stage 1 phase and the final dam completion phase, the flood attenuation thanks to the reservoir routing is taken into account.

### 2.4 Structural criteria

Flood diversion during construction is ensured by tunnels. Design criteria for these tunnels are presented in this paragraph.

#### **2.4.1 Existing tunnels (DT1 and DT2)**

These structures have been extensively studied under the Phase I report leading to the following recommendations:

- The deposit of material proceeding from the cofferdam collapse and from the mudflow of Obi Shur creek should be removed before the river diversion. This activity has been accounted for in the cost estimate and overall schedule of the project.
- Due to the inherent structural limitations of these existing facilities, the Consultant deemed necessary that the use of the two diversion tunnels as spillways should be limited both in respects to the time and to the water head.
- As they will probably need heavy rehabilitation works, it is already considered in this analysis that they will be reduced by 30 cm along their whole perimeter as a provision for rehabilitation works.
- These tunnels shall work under a maximum head of 120 m.

#### **2.4.2 New tunnels**

- The maximum head tolerated in these new tunnels (temporary structures) is 120 m. This value can be overpassed by 30 m, ie 150 m, in extreme condition such as high floods or seismic event.
- This limit is set in order to keep the maximum water speed through the gates openings within the limits proposed here below, so to avoid cavitation, excessive air entrainment and flow instability phenomena.

#### **2.4.3 Ionakhsh fault**

- Co-seismic displacements in Ionakhsh fault could be of the order of magnitude of 1 m in case of large earthquake (MCE).
- No probability can be associated with this event. But the project should survive in spite of its occurrence: the protecting structure should not collapse. This shall be considered as an extreme scenario.

### 3 HPI DIVERSION SCHEME

#### 3.1.1 Description

According to HPI scheme, from the river diversion to the completion of the final dam, 6 different structures are used to divert and discharge the floods:

- Diversion tunnel of 1<sup>st</sup> level (DT1)
- Diversion tunnel of 2<sup>nd</sup> level (DT2)
- Diversion tunnel of 3<sup>rd</sup> level (DT3)
- Operational tunnel of 3<sup>rd</sup> level (OP3)
- Remote spillway (RS)
- Operational shaft spillway (OSS). The remote spillway and the operational shaft spillway share the same downstream tunnel and outlet.

The next figure presents the location and inlet elevation of the various diversion and spillway structures. The next table presents their main characteristics.

	Type and size	Sill elevation
<b>DT1</b>	Pressured Tunnel, D-shaped, 95.55 m <sup>2</sup>	989.60
<b>DT2</b>	Pressured tunnel, D-shaped, 95.55 m <sup>2</sup>	1001.80
<b>DT3</b>	Pressured tunnel, circular Ø15 m	1035
<b>OP3</b>	Pressured tunnel, circular Ø15 m	1145
<b>RS</b>	Pressured tunnel, circular Ø11 m	1145
<b>OSS</b>	Gated weir, L=40 m	1288

**Table 49: Main Characteristics of HPI Diversion Tunnels**



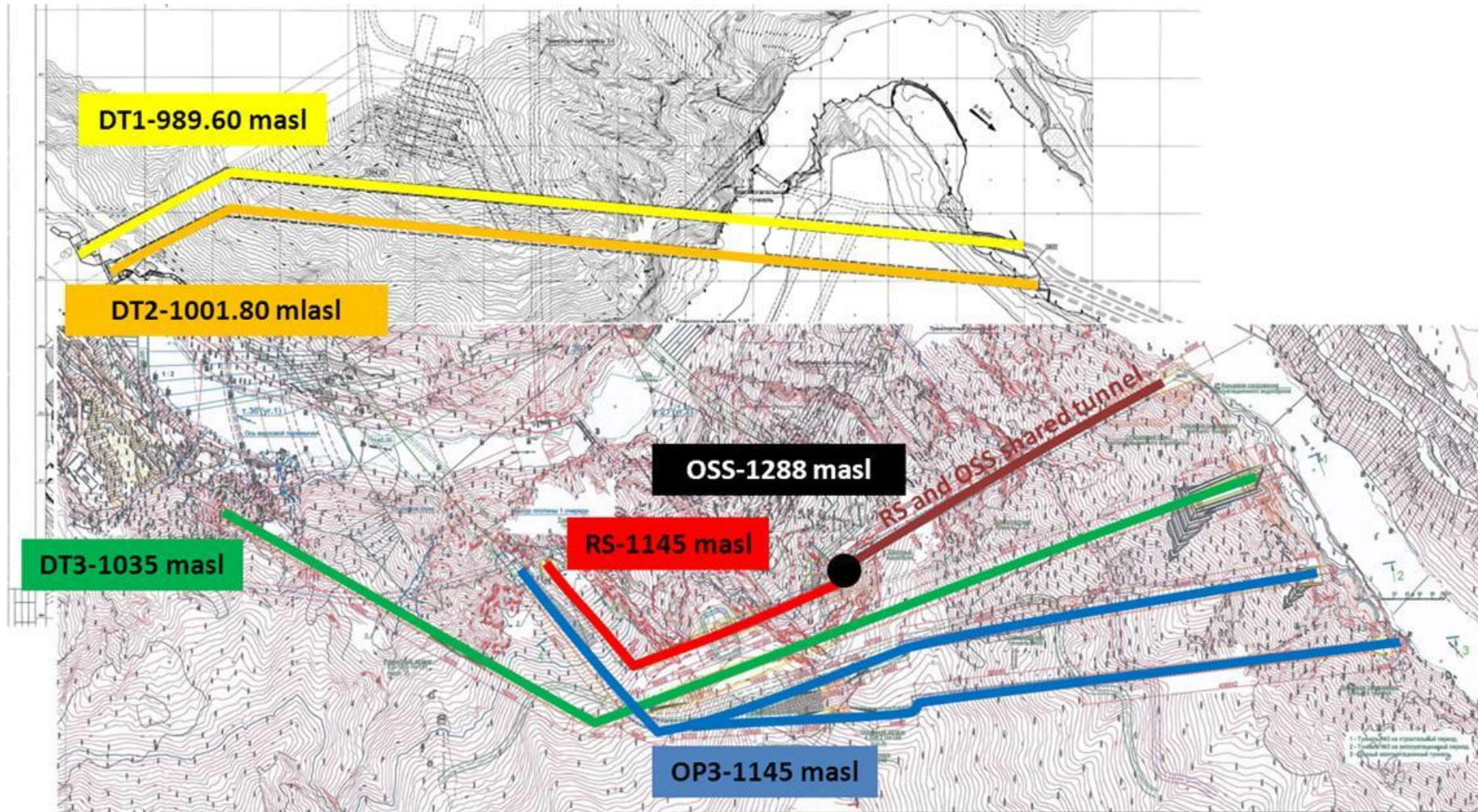

Figure 25 : Plan view - Diversion and spillway structures – HPI scheme

### 3.2 Assessment

According to the Consultant criteria, several items appear not to be fully safe:

- The level of protection of the cofferdam is not sufficient (about 7 years);
- The water head that all structures (temporary or final) have to undergo is too high (largely above 150 m for existing and new tunnels);
- The Ionakhsh fault particularity is not mentioned and no remedial measures are proposed to cope with its displacements whereas there is a significant construction period of high dependence on DT3.

Therefore, the Consultant proposed another flood management scheme that is detailed in the following paragraphs.

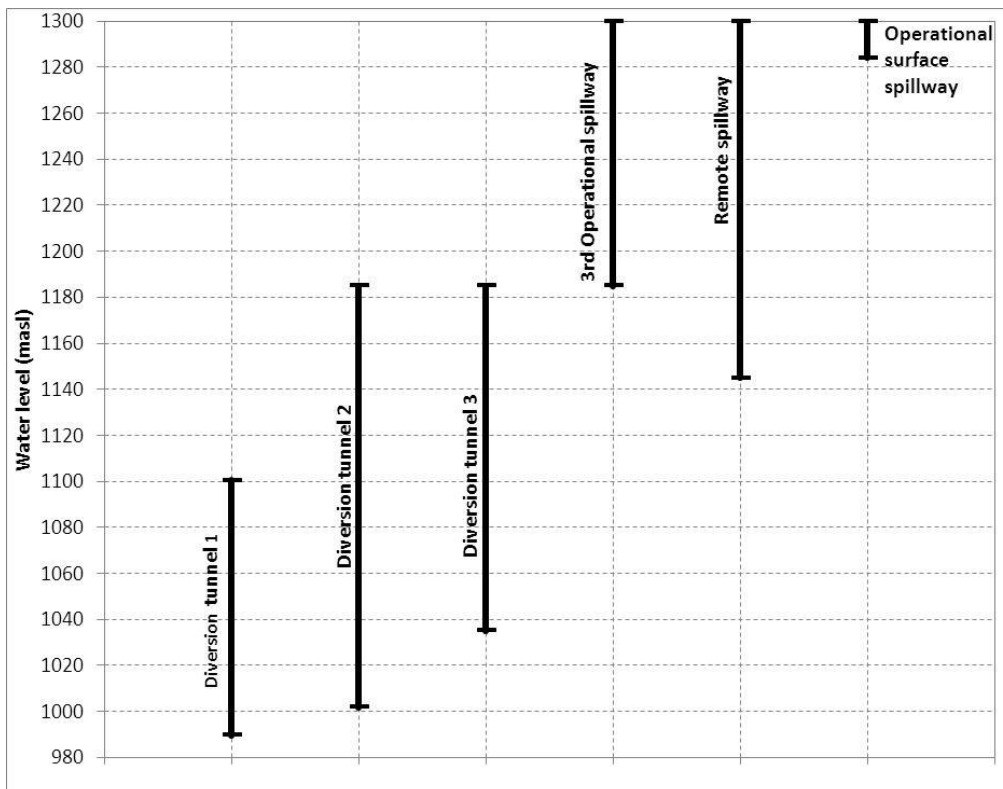

Figure 26 : Operation range of discharge tunnel - HPI

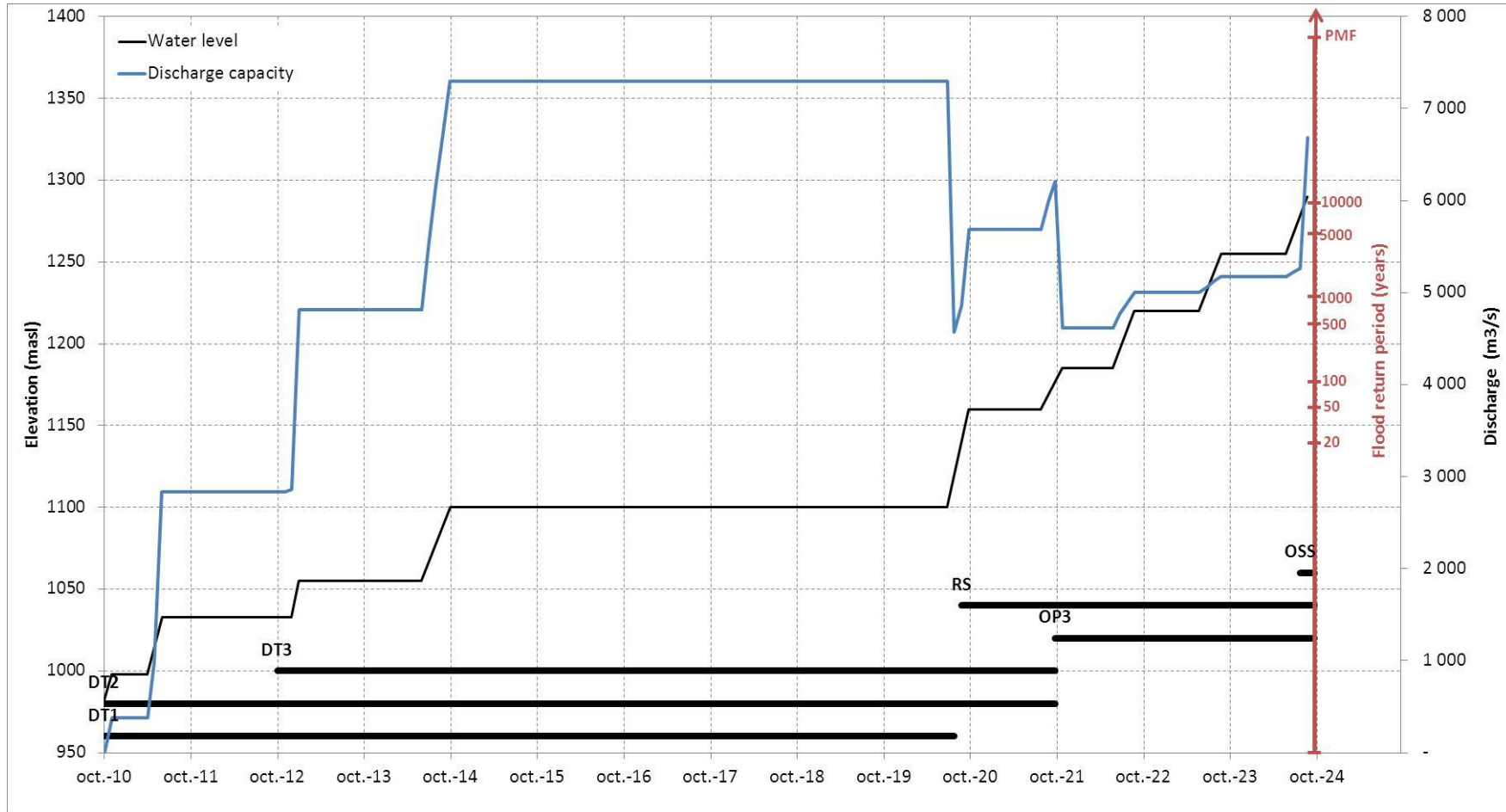

Figure 27 : HPI Diversion scheme



## 4 DESCRIPTION OF PROPOSED DIVERSION STRUCTURES

All hydraulic characteristics of the diversion tunnels have been studied in details to establish the layout proposed for each dam height alternative.

The various diversion structures considered are:

- Diversion tunnel 1 and 2 ( DT1 and DT2);
- Diversion tunnel 3 (DT3);
- Mid-level outlet 1 and 2 (MLO1 and MLO2);
- High level tunnels 1, 2 and 3 (HL1, HL2 and HL3).

The plan view of these proposed structures is presented in the next figure.

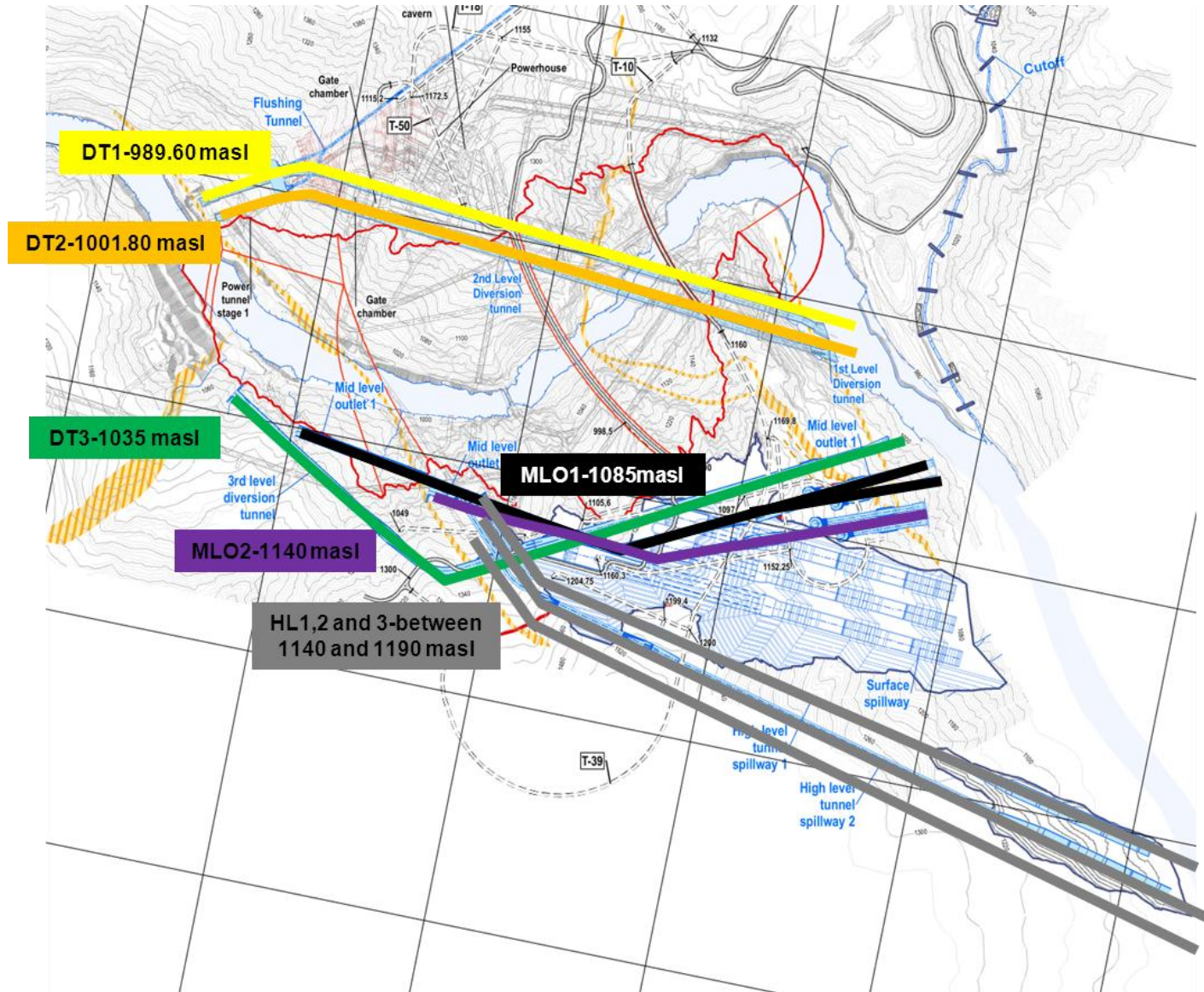

Figure 28 : Plan view - Diversion structures proposed:

#### 4.1 Upstream and downstream cofferdams

The upstream cofferdam is part of the final dam. Once the Stage 1 dam is raised above the cofferdam, it is used as protection structure. When the final dam reaches Stage 1 crest elevation, it is used as its own protection structure.

There are two downstream cofferdams:

- The first one (DS cofferdam 1) is located just downstream of DT1 culvert (see following figure). It is used until DT1 and DT2 stretches on the right bank are completed and allows discharging water further downstream; it is used only during the “cofferdam” phase;;
- The second one (DS cofferdam 2) is just upstream of DT1 and DT2 right bank outlet (see following Figure 29). It is actually part of the final dam toe. It is used from the beginning of “Stage 1 phase” to the final dam completion.

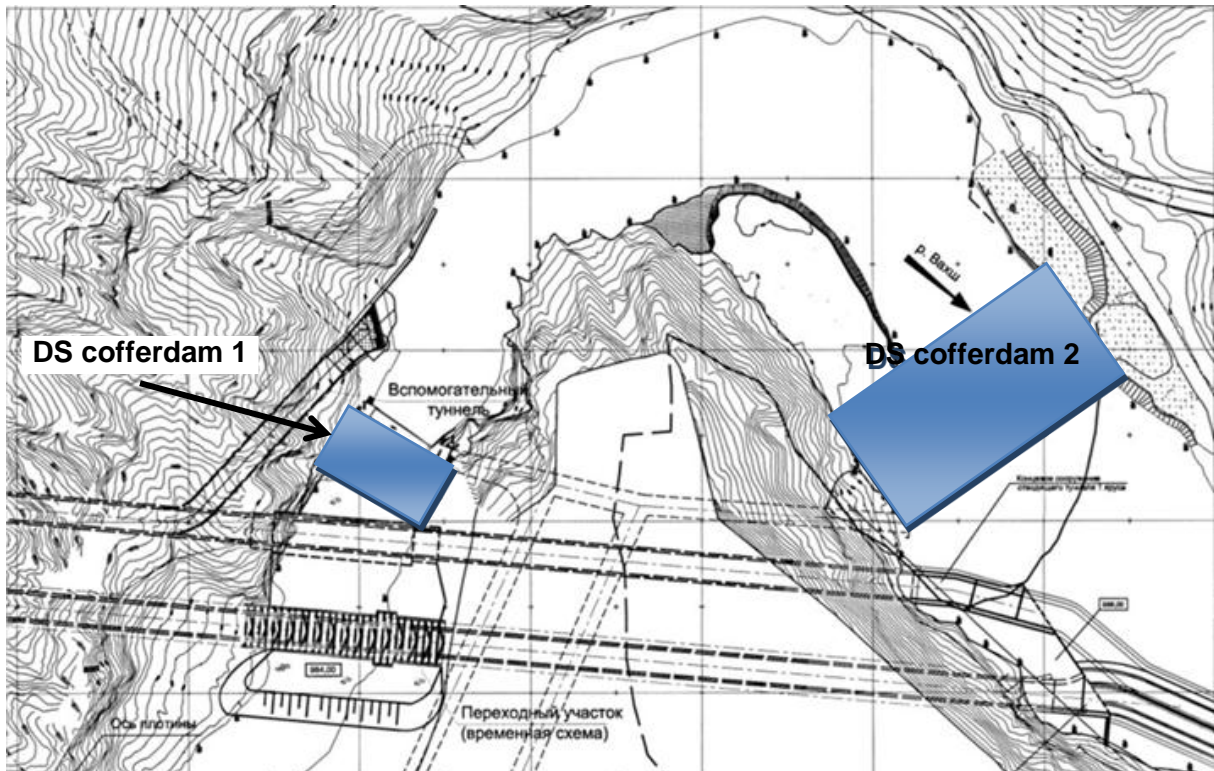

Figure 29 : Location of downstream cofferdams

## 5 CONCLUSIONS AND RECOMMENDATIONS

### 5.1 Cofferdams

The construction flood considered for the cofferdam is the 100 years return period flood, ie a probability exceeding 1/100. The cofferdam crest elevation is then 1050 masl. During this phase, the construction flood is discharged through DT1, DT2 and DT3.

Downstream cofferdam of this phase is called the DS cofferdam 1 and its crest is set up at elevation 994 masl that protects it against a 100 years return period flood.

The most critical structure of the diversion scheme during this phase is the DT3, which can be put out of service in case of large earthquake, and consequent large co-seismic displacement.

If DT3 is out of service because of the co-seismic displacement in Ionakhsh fault, the cofferdam will be protected only against a 10 years return period flood (probability exceeding 1/10). In case of higher flood combined with a large earthquake, the cofferdam will most probably be overtopped leading to failure of the cofferdam. However, the volume of water release can be damped in Nurek reservoir (about 50 cm of Nurek reservoir level increase). This combination of unfavorable events is highly unlikely and this risk is considered acceptable by the Consultant.

### 5.2 Stage 1

The construction flood considered for the Stage 1 dam is the flood with a probability of exceedance of 1/100 over the construction period. It matches the 400 years return period flood for stage 1 at 1110 masl, 300 years return period for the stage 1 at 1090 masl, and the 200 years return period flood for stage 1 at 1075 masl. These construction floods are discharged with DT1, DT2 and DT3.

Downstream cofferdam of this phase is the DS cofferdam 2. For the construction flood considered, the water elevation is 984.2 masl, and therefore the downstream cofferdam crest shall be 986 masl.

Sensitivity analysis to the unavailability of DT1, DT2 or DT3 has been carried out and the risk associated with one of these events is considered acceptable.



### 5.3 During the main dam body construction

The construction flood considered for the last phase of the construction has a probability of exceedance of 1/200. This matches the 600 years return period flood for the dam alternatives FSL=1220 masl, the 1000 years return period flood for the dam alternatives FSL=1255 masl and the 1200 years return period flood for the dam alternatives FSL=1290 masl.

From water elevation 1100 masl, the construction flood is discharged through DT3 and MOL1.

For the higher dam alternative (1290 masl), DT3 is switched off at water elevation 1160 masl. From 1160 masl to 1215 masl, the construction flood is discharged through MOL1 and MOL2. From 1215 masl to 1270 masl, the construction flood is discharged through MOL2 and HL1. Above 1270 masl and until dam completion, the construction flood is discharged through HL1 and HL2.

For the medium dam alternative (1255 masl), DT3 is switched off at water elevation 1170 masl. From 1170 masl to 1210 masl, the construction flood is discharged through MOL1 and HL1. Above 1210 masl and until dam completion, the construction flood is discharged through HL1, HL2 and HL3.

For the lower dam alternative (1220 masl), DT3 is switched off at water elevation 1165 masl. From 1165 masl to dam completion, the construction flood is discharged through MOL1 and HL1.

Downstream cofferdam of this phase is the DS cofferdam 2, the relevant rating curve is the "Section 1". For the construction flood considered (600, 1000 or 1200 years return flood depending on the alternatives), the water elevation is 984.4 masl, 984.5 masl or 984.6 masl depending on the alternative, and therefore the downstream cofferdam crest shall be 986 masl.

MLO1 layout has been developed in order to avoid crossing the Ionaksh fault and therefore reduce the risk of its failure in case of Ionaksh fault co-seismic movement. No feasible layout exists to avoid crossing the Ionaksh fault with DT3. Some mitigation measure can be put in place in the fault stretch to face at least the creeping effect and moderate displacements of moderate entity.

Moreover, the probability of having both a high flood and an important seismic event able to make these tunnels collapse within their life span is limited. This risk is considered acceptable by the Consultant.

## 5.4 Summary

All the above is now synthesized in the two following illustrative sketches for each dam alternatives.

The first one presents the operating range of each structure along a water level axis. The black lines show the normal operating range and the dotted lines represent the exceptional additional operating range. It indicates the water elevation for which each tunnels should be switched on (low line extremity) and off (high line extremity).

The second one presents the protection level, operating structures, and maximum water level all along the construction period.

Refinement of the discharge structures will be performed in further design stages for the selected alternative. Also, in line with the cautious system for flood management during construction presented in this chapter, including safety measures such as the limitation of the water head on gates and the redundancy of works, a flood forecasting and warning system shall be designed and implemented to be operational during the complete duration of Rogun construction.

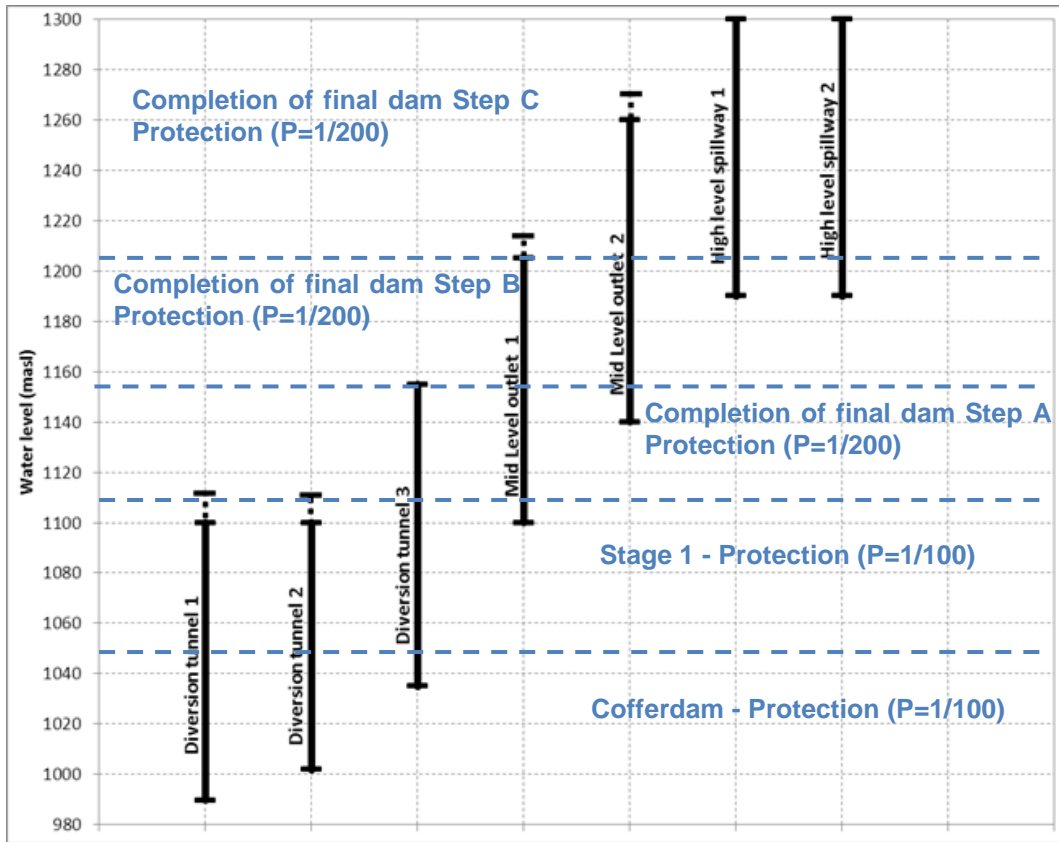

Figure 30 : FSL = 1290 masl - Diversion structures operating range

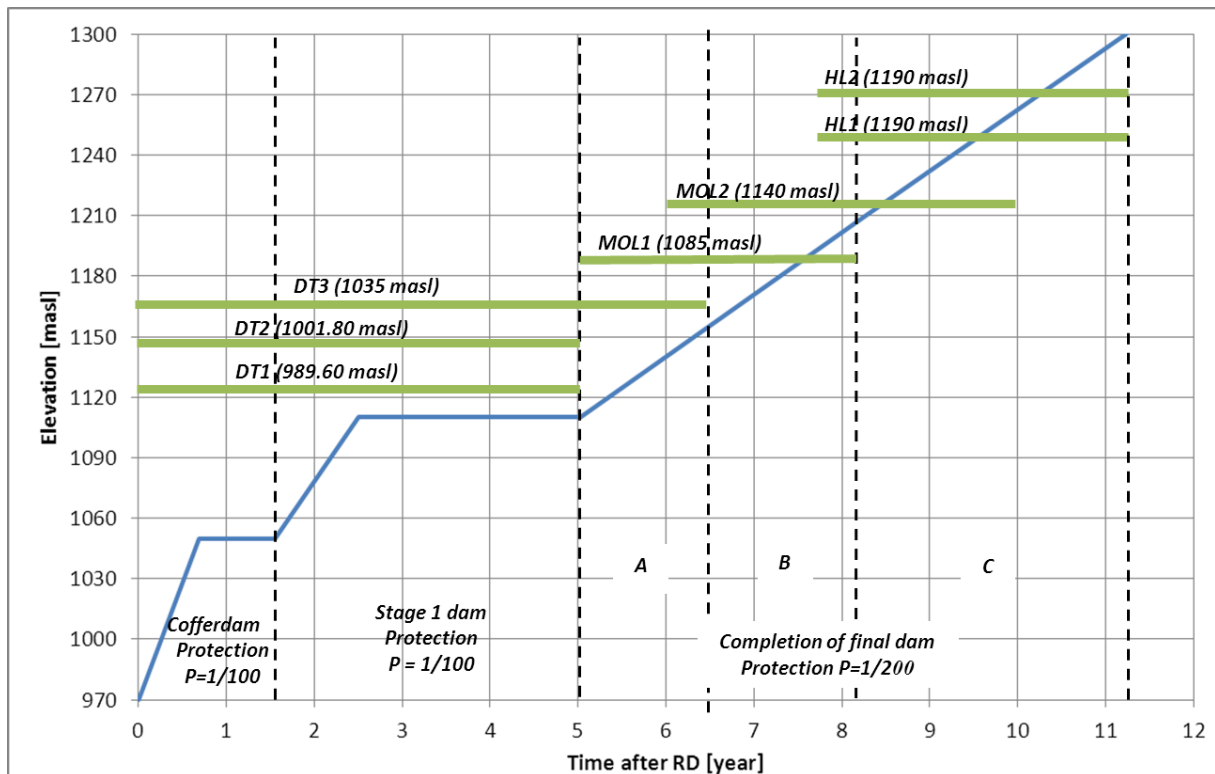

Figure 31 : FSL = 1290 masl - Diversion scheme along time

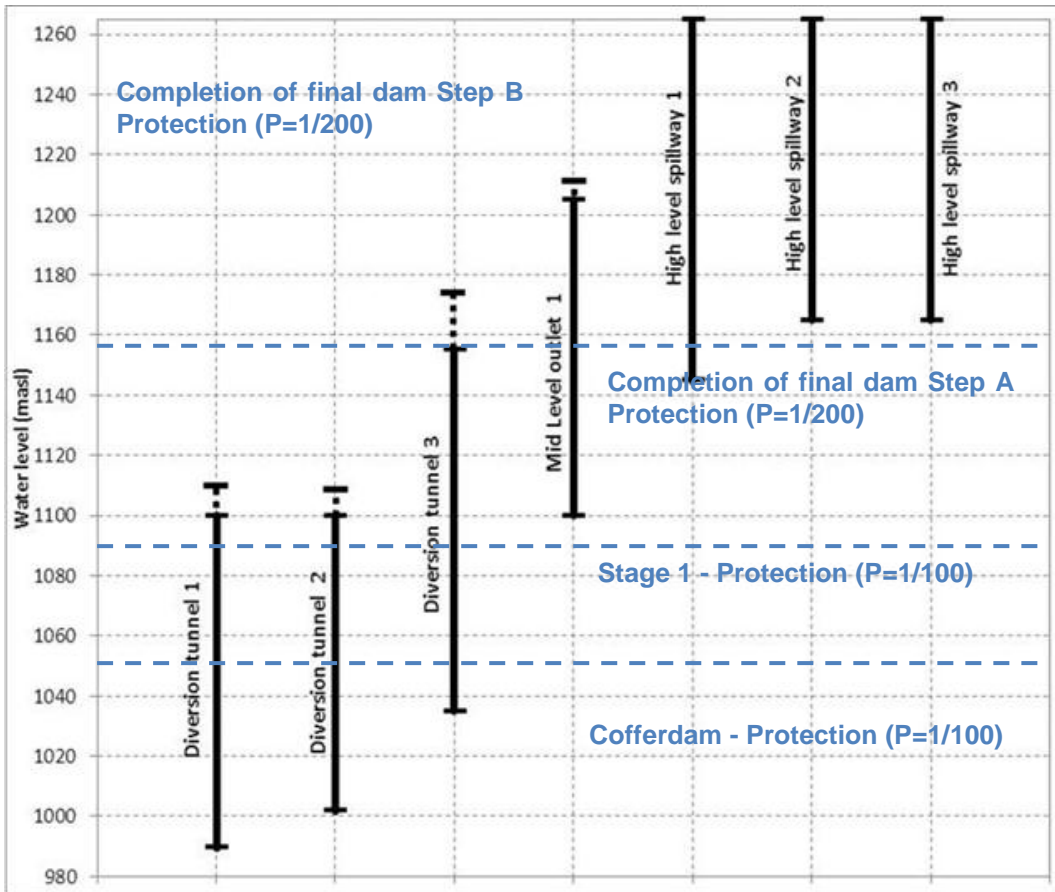

Figure 32 : FSL = 1255 masl - Diversion structures operating range

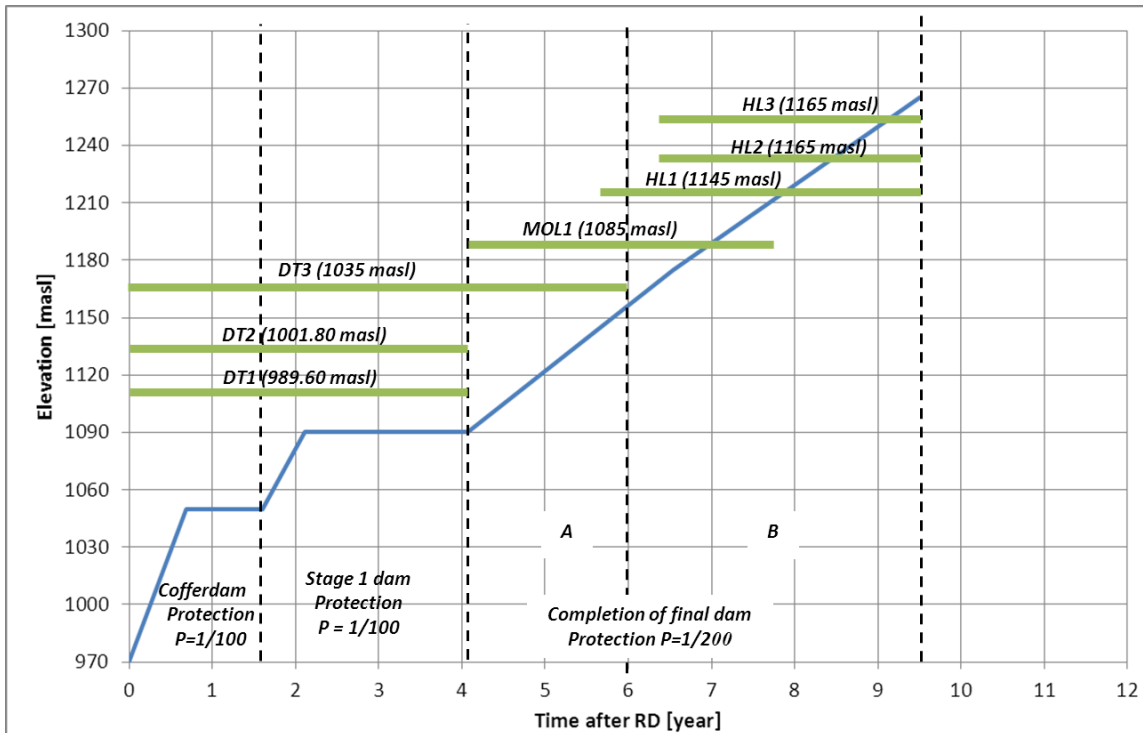

Figure 33: FSL = 1255 masl - Diversion scheme along time



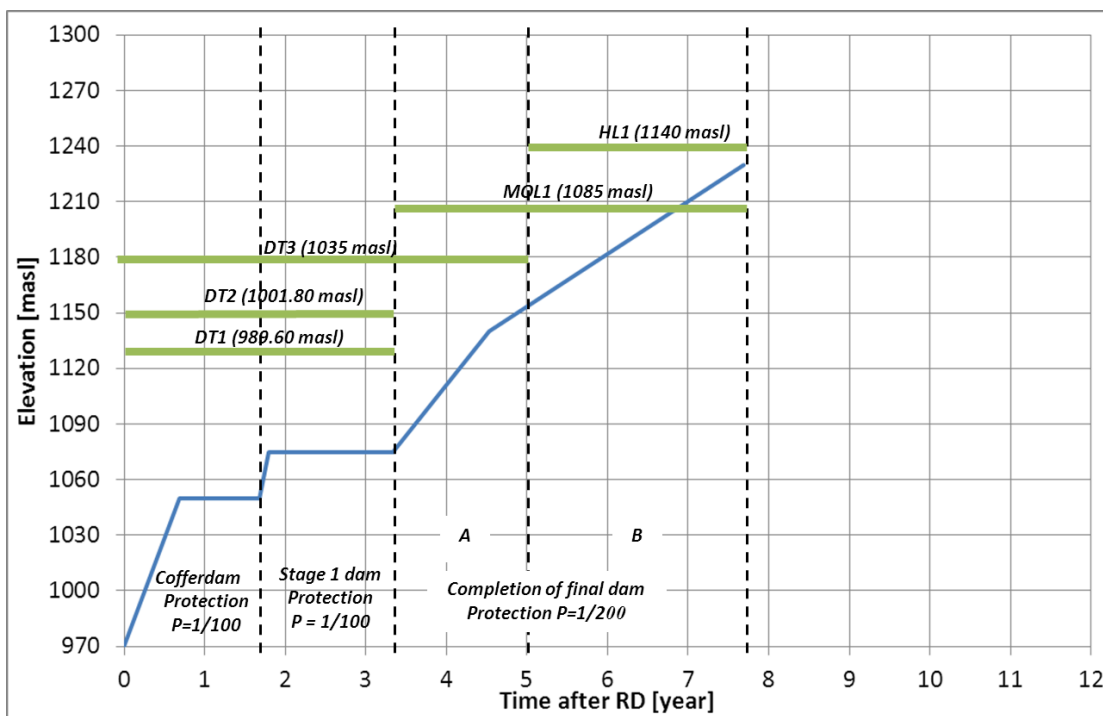
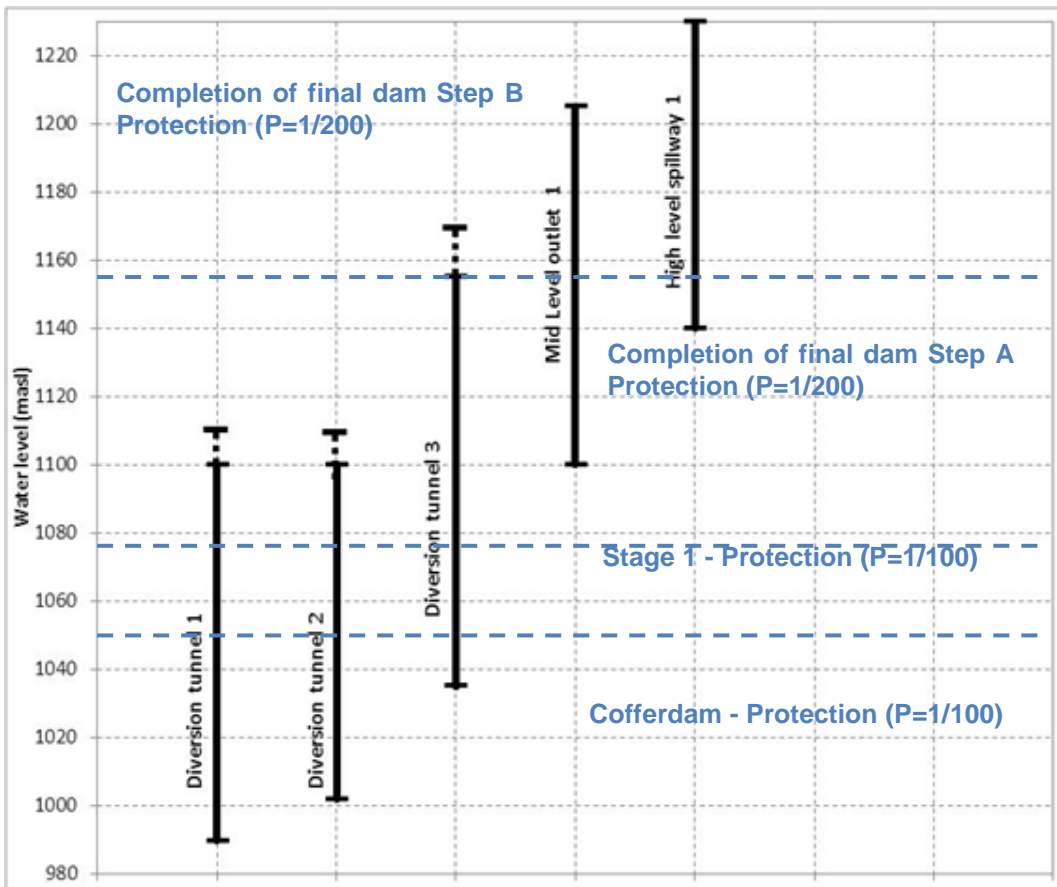

Figure 34 : FSL = 1220 masl - Diversion scheme along time

## **CHAPTER 3.3: APPENDIX 4 – HYDRAULICS OF PROJECT COMPONENTS**

### **1 CONCEPTS ADOPTED FOR THE DESIGN OF HYDRAULIC FACILITIES**

#### **1.1 Introduction**

This chapter deals with the analyses carried out in respect to the behavior of the hydraulic facilities proposed for flood management, both during the construction phase and the plant operation, related to the different dam height alternatives presented for optimization of the Project scheme.

The features of the hydraulic facilities were defined for each proposed alternative according to the discharge capacity and number required at various elevations, as discussed in report “Flood Management during Construction” (Appendix 3).

Consideration was also given to the criteria proposed for the safety of the construction works and of the limitations in operating the above facilities, in particular the condition that a discharge tunnel would not normally be operated under a head higher than 120 m and exceptionally reaching 150 m. This criterion is based on limiting the high water velocity in the gates section and inside the tunnels.

The aspects related to the sediment management also have a significant impact on the selection of the discharge facilities, leading eventually to the proposed solution of a surface spillway as the only possibility to provide safety to the dam in the very long term, when the reservoir will be completely silted.

The proposed hydraulic facilities and the general concepts applied in their design are presented below, before detailed analyses of the hydraulic behavior of the different components are reported.

It is to be noted that, given the characteristics of the hydraulic facilities in terms of heads and floods, studies on physical models are recommended for all of them in the detailed design stage.

#### **1.2 Diversion Tunnel 3**

Diversion Tunnel 3 (DT3) is needed mainly during the construction of the cofferdam and the Stage 1 configuration of the dam, up to el. 1,110 m a.s.l.

According to report “Flood Management during Construction” (Chapter 3.3 - Appendix 3), the tunnel should be ready to operate starting from the date of the river diversion, since the discharge capacity required to protect the cofferdam cannot be assured by the existing diversion tunnels 1 and 2 only. The analyses carried out indicated a need for evacuating the 100-year return flood for a life span of two years, ensuring protection against a risk of 1/50 with a cofferdam crest at 1,050 m a.s.l.

DT3 crosses the Ionakhsh Fault. Despite the fact that provisions have been made to mitigate the effect of large displacements in correspondence with the fault, the possibility of an interruption or serious collapse due to a strong earthquake cannot be disregarded. If this happens, only diversion tunnels 1 and 2 will operate, while the cofferdam with a crest at el. 1050 m a.s.l will be protected against a flood with a return period in the order of 10 years only.

During the studies, the possibility to find an alternative route in the left bank was examined, with the aim to avoid the crossing of Ionakhsh Fault. However, this possibility was discarded because of several physical constraints and difficulties, in particular linked to the Obi Shur creek crossing, as well as higher costs and a longer construction period.

The upstream stretch of diversion tunnel 3 was located on the alignment and at the elevation of intake proposed by HPI, i.e. 1,035 m a.s.l, while the downstream portion was rerouted because of a space need for the remaining hydraulic facilities.

The main components are the water intake, the pressure stretch of tunnel up to the emergency and sector gate chamber, the maintenance/emergency gate chamber, the downstream free-flow stretch, and the outlet structures.

In consideration of the low difference in elevation between the outlet portal and the riverbed, a simple chute with a terminal flip bucket has been designed to discharge the water back to the river downstream from the dam.

The tunnel will remain in use until the intakes are plugged, otherwise the silted material entering the tunnel will seriously damage it, and stability will no longer be ensured.

### 1.3 Middle Level Outlet 1

The Middle Level Outlet 1 (MLO1) is required for dam protection during the construction starting from water elevation 1,100.0 m a.s.l, which is also the limit of normal operation of Diversion Tunnels 1 and 2 (120 m head).

The general features of the tunnel pressure stretch are the same as these of Diversion tunnel 3, but specific solutions had to be implemented for the intake and for the energy dissipation at the outlet.

The inlet arrangement foresees an 18 m wide and 18 m high concrete culvert crossing the dam embankment from the upstream shoulder to the foundation rock surface, so that the tunnel proper is starting shortly downstream from the Ionakhsh Fault crossing. The culvert, with an inlet at el. 1,083.5 m a.s.l, is a robust structure constituted of short stretches with thick walls. Possible displacements at the Ionakhsh Fault section can occur without interrupting the flow to the tunnel.

The outlet area elevation is about 1075 m a.s.l, so there is a considerable difference in elevation with respect to the riverbed and the problem of discharging the flow, in the order of 3,700 m<sup>3</sup>/s, required proper consideration, to avoid scouring effects and possible banks-triggered instability.

The possibility to implement a chute with a terminal flip bucket was examined. However, this solution implied a water velocity of the order of 50 m/s at the chute end. This figure, together with a specific discharge in the order of 105 m<sup>3</sup>/s/m, implies a risk of cavitation and possible important scouring effects; in consequence the solution was discarded.

Subsequently, a solution with vortex chambers and drop shafts was analyzed, which allows dissipating a large percentage of energy while keeping the water velocity within acceptable ranges for hydraulic structures.

It shall be noted that this way the specific flow at the outlets is much lower and thus a better control of the scouring effects can be achieved.

In addition to the solution with vortex shafts, with the aim to reduce the number of outlets and therefore the points of impact into the Vakhsh River, the possibility to discharge into the cascade system envisaged at the outlet of the surface spillway, constituted by a sequence of chute and stilling basins, was analysed and finally adopted.

The tunnel pressure stretch, with inner section of 15 m diameter, is branching into two circular tunnels with 10.8 m inner diameter, each provided with an emergency and sector gates chamber, running along the same axes of the surface spillway and connected with two corresponding channels.

Since the water speed for the design flow of about 1,840 m<sup>3</sup>/s is substantially the same occurring when the surface spillway is operating, the hydraulic behavior is compatible with the analysis carried out for the latter structure, being the impact in the riverbed even more favorable due to the lower specific discharge.

#### 1.4 Middle Level Outlet 2

The Middle Level Outlet 2 (MLO2) is required for dam protection during the construction of the alternative with FSL = 1290 only.

The elevation of intake of the MLO2 is set at 1140 m a.s.l, and the general features of the tunnel pressure stretch are the same as those of DT3 and MLO1. However, in this case the solution implemented at MLO1 to face the energy dissipation at the outlet could not be adopted, and the vortex chambers and drop shafts arrangement is proposed.

Due to the large flow involved, it was split into two streams, which allows bringing the maximum individual discharge of each shaft to about 1850 m<sup>3</sup>/s; vortex shafts with this capacity have already been constructed.

In this case, the tunnel inlet portal is located downstream from the Ionakhsh Fault, thus no special arrangement was required for the intake. No major problems due to seismic events are expected, even though a number of joints and Fault 35 will be crossed in the vicinity of the discharge tunnels outlet portals. For the latter, provisions have been made at fault crossing to withstand possible creeping effects.

#### 1.5 High Level Tunnel Spillways

These structures, which have been proposed to evacuate the floods both during the final phase of dam construction and after the dam is completed, shall operate for the entire lifespan of the plant until it is decommissioned.

The tunnels general features are the same for all alternatives, but their number has been defined case by case according to the needs defined in the chapter on construction floods management.

The elevation and number of high-level tunnel spillways for the different alternatives are as follows:

- Alternative with FSL 1290: two HLTS with intake at el. 1,190.0 m a.s.l.
- Alternative with FSL 1255: three HLTS, out of which one with intake at el. 1,145.0 m a.s.l. and the remaining two with intake at el. 1,165.0 m a.s.l.
- Alternative with FSL 1220: one HLTS with intake at el. 1,140.0 m a.s.l.

The noticeable difference of elevation between the outlet at gates chamber elevation and the riverbed, between 150 and 200 m, led to study a solution that had to effectively dissipate energy while keeping the hydraulic parameters (water velocity, cavitation index, specific flow) within the ranges commonly accepted for long-term structures.

A system combining cascade elements such as chutes, ogee crest and stilling basins, which according to the performed computations allow fulfilling the above requirements, was therefore proposed.

According to the standard arrangement, three chutes and two intermediate stilling basins are foreseen, the last chute being provided with a terminal flip bucket. The described sequence has been adopted for all HLTS proposed, adapting the slopes and height of the chutes to the morphological conditions and to the difference in the total elevation.

It is to be noted that the HLTS intakes of each alternative are placed higher than the power intakes of the corresponding generating waterways: by the time the reservoir is silted up to the elevation of HLTS intakes, the power intakes would have been already reached by sediments and decommissioned, if the multi-level intakes were not implemented.

At that point, the HLTS will be decommissioned and only the surface spillway will be used to ensure the safety of the dam.

## 1.6 Multi-level Intakes

In the "Reservoir Sediment Management" report, various alternatives to mitigate the impact of a huge amount of sediments on the Rogun plant operation in general, and on its useful lifespan in

particular, have been examined, but most of them were deemed inapplicable, very costly, or inadequate to the situation of Rogun.

The Consultant firstly proposed to implement facilities for performing the sediment flushing in the areas more sensitive to the problem of the silting, through tunnels located in the left bank, just below the power intakes. However, this solution was deemed to be not viable due to the high head. Some other drawbacks were also noted, linked to the necessity to cross the Obi-Shur creek.

Therefore, it is proposed to adopt multi-level intakes, which allow the entrance of the flow from the reservoir at different elevations. The benefits of these intakes are potentially two-fold: first these intakes will permit water to flow to the power waterways even when the sediments deposit will be higher than the headrace tunnel elevation, extending thus the plant life by several decades; secondly these intakes could also allow possible passage of turbidity currents through the turbines, if this is determined to be a viable option, which may also extend the operating life of the plant.

The multi-level intakes solution proposed for Rogun consists of an inclined concrete culvert, resting on the bank slope in correspondence with the power waterways inlets, provided with openings at various levels, spanning from elevation 1,090 m a.s.l. up to the dam crest elevation.

## 1.7 Surface Spillway

As part of the TEAS, the Consultant must assess the existing design developed by the Hydroproject Institute, develop three alternative dam heights designs, and propose the most convenient one for further development.

HPI's design includes a 335 m high embankment dam, with FSL at 1290 m a.s.l. Two tunnels ensure flood evacuation during the useful life of the project, with intakes at elevation 1,145 and an overflow structure with sill at el. 1,288, connected to a vertical shaft and then to a sub-horizontal tailrace tunnel.

With a reservoir capacity at the above-mentioned elevations of 1,145 m a.s.l and 1,288 m a.s.l, representing 1,500 hm<sup>3</sup> and 13,000 hm<sup>3</sup>, respectively, and considering the estimated annual volume of sediments transported, sediments horizontally deposited would reach these elevations in 50-80 years and 130-210 years, respectively. Depending on how sediment is deposited, longer

periods of time can be expected, but it is in any case necessary to consider how floods may be managed in the future.

The design of the evacuating facilities in the three dam height alternatives of the TEAS considers intake elevations higher than these of the HPI's design, but the advantage in terms of useful life is only marginal.

Under these circumstances the only way to ensure a safe flood evacuation to protect the dam and the downstream population is by introducing a surface spillway.

## 2 DIVERSION TUNNEL N° 3

### 2.1 Overview of DT3

Diversion Tunnel 3, with an intake set at el. 1,035, consists of a pressure operation tunnel stretch, with a circular cross-section of 15.0 m in diameter, 810 m long and 0.65% sloped up to the sector and emergency gate chamber, followed by the free flow tunnel stretch, 0.7 % sloped, with a 14.5 m wide and 17.0 m high horseshoe cross-section. The downstream facilities are composed of a chute with a terminal flip bucket. The tunnel is also provided with a maintenance/emergency gate chamber located at some 460 m from the intake.

The layout and dimensions of the structures (intake, tunnel, gates, etc.) are the same for the three dam alternatives.

At the end of the pressure reach, the tunnel presents a transition to a rectangular cross-section 26.2 m wide and 7.1 m high, where the approx. 201 m long sector and emergency gate chamber, is located. The chamber is equipped with four slide gates and four sector gates. The four conduits where the gates are located, as well as short stretches of the adjacent transitions are lined in steel.

The maintenance/emergency gate chamber is proposed to be equipped with four wheel gates similar to these installed in the emergency gate chamber: the gates, with an area of about 30 m<sup>2</sup>, can be operated under flow with the maximum head. If large displacements at the fault section provoke damages to the inner lining and block the downstream gates, this makes it possible to shut down the tunnel and carry out repair works.

In order to prevent cavitation, a number of measures have been implemented at the gates chambers, including steel lining along the stretches close to the gates, aeration provisions



downstream from the same gates and very gradual transitions to the tunnel current cross sections, both upstream and downstream of the chambers.

At the outlet, a 14.5-30 m wide and 90 m long chute with a divergent cross section and a terminal flip bucket system was provided, discharging into the Vakhsh River.

## 2.2 Hydraulics of the Diversion Tunnel DT3

### Tunnel Pressure Stretch

The upstream reach of the tunnel up to the sector gate chamber will normally operate under pressure conditions. The discharge capacity depends on the available net head between the reservoir and the gates accounting for the various head losses, which are calculated according to USBR recommendations or to reputable authors in the field. Friction head losses are generally based on a Manning's coefficient of  $0.012 \text{ s/m}^{1/3}$ .

According to the above approach, when the gates are fully open, the maximum discharge for an exceptional design head of 150 m is  $3,694 \text{ m}^3/\text{s}$ , and the corresponding maximum water velocity is about 21 m/s, which increases up to 30 m/s in the conduits upstream of the gates.

The computational approach adopted in order to define the Head-Discharge curve is conservative since the effects of various factors linked to the complex physical phenomena were not accounted for. In reality, the discharge capacity could be somewhat higher than calculated.

### Tunnel Free-flow Stretch

The water surface profiles in steady flow conditions downstream from the sector gates have been evaluated by implementing a hydraulic model based on the integration of the gradually varied flow equation. The STEFLO software was adopted to implement the model.

The main problems that could occur in the free flow reach immediately downstream from the gates are possible shock waves, air–water mixture plugs, and air entrainment.

In order to reduce the risks linked to the above phenomena, which may cause strong instabilities and cavitation, various provisions have been implemented, such as the adoption of a fairly gradual transition downstream from the gates with an angle of the order of  $4^\circ$ , and of steel lining. Furthermore, an air duct system was located immediately downstream from the control gates, and

the aeration around the same was provided by enlarging the section laterally and by designing a step in the floor which makes it possible to bring air below the jet.

According to empirical evidence, the air demand associated with the carrying capacity corresponds to approximately 25% of the water discharge.

For the maximum discharge, the freeboard in the reach operating in free flow conditions represents about 25% of the total tunnel height.

### Flip Bucket

The jet trajectories corresponding to different angles examined (30°, 25° and 20°) were calculated by applying the USBR formula that gives the trajectory of the lower nappe of the jet, finding that the impact occurs at a distance from the lip of the flip bucket from 183 to 157 m.

In consideration of the above, 20° are selected as the take-off angle of the flip bucket.

### Plunge Pool

The basic parameter to check whether there is a need for a plunge pool is the depth of erosion, which can be calculated by means of several empirical formulas, mainly depending on head drop and specific discharge.

The field of variation of the scour depth  $D = t + h$  obtained by the application of empirical formulae is between 42.8 and 77.0 m, while the average value is 58 m.

In order to verify the scour depth calculated with the empirical formulae, a theoretical approach, based on the assessment of hydrodynamic pressure of the underwater jet, was applied.

Considering a pressure value of  $15 \text{ T/m}^2$  ( $1.5 \text{ kg/cm}^2$ ) as an erodibility threshold, it was found that this value is reached at a distance of 40 m along the axis of the bulb for the  $3,694 \text{ m}^3/\text{s}$  discharge: a pre-excavation of about 25 m from the tailwater level down to elevation 955 m a.s.l. is thus recommended.

## **3 MIDDLE LEVEL OUTLETS 1 AND 2**

### 3.1 Overview of Middle Level Outlets 1 and 2

According to the results of the studies presented in “Flood Management during Construction”, two Middle Level Outlets are proposed for the alternative dam with FSL = 1,290. For the alternatives with FSL = 1,255 and 1,220, the complex of hydraulic facilities only includes Middle Level Outlet 1.

The Middle Level Outlet 1 (MLO1) intake is set at el. 1,083.5, and is made up of the entrance to a 300 m long culvert, with a D-shaped inner cross section of 18.0 m in diameter. At the end of the culvert, there is a transition leading to a 15.0 m in diameter circular tunnel, with a slope of 0.65%. The invert elevation of the portal inlet is 1,085.0 m a.s.l. The pressure tunnel extends for about 1000 m from the intake and then branches into two smaller circular tunnels with 10.8 m diameter.

The tunnel proper (excluding the culvert structure) extends for about 880 m up to the sector and emergency gate chambers, each followed by a free flow tunnel, with a D-shaped cross-section 12 m wide and 12 m high. The profile of the last reach of the tunnels shows a vertical bend and connects with the surface spillway flip buckets floor.

The layout and dimensions of the structures (intake, tunnel, gates, etc.) and relevant elevation are the same for the three dam alternatives.

The Middle Level Outlet 2 (MLO2) consists of a pressure tunnel, followed by a free flow tunnel, two vortex inlets and drop shafts, two tailrace tunnels and relevant outlets with chute and flip bucket downstream from each shaft.

The intake is set at El. 1,140.0, and the pressure tunnel, with circular cross-section of 15.0 m diameter, extends for about 715 m up to the sector and emergency gates chamber, which houses four slide gates and four sector gates. The maintenance gates chamber, provided by two slide gates, is located at a distance of about 400 m from the intake. The gates conduits, as well as short stretches of the upstream and downstream transitions, are steel lined.

Downstream from the sector and emergency gates chamber, a rectangular cross-section 15.8 m wide and 9.1 m high to the springline with a circular arch roof, reaching a maximum height of 17.0, m has been adopted. The section is divided in two halves by a 1.80 m thick wall, each barrel leads to the intake structure of the vortex drop shafts, located shortly downstream.

Each shaft, with a 14 m diameter, is about 100 m high, and is connected to the free flow tailrace tunnels through a vertical curve.

The free flow tailrace tunnels, one for each shaft, with circular cross section of 12 m diameter, extend from the bottom of the shafts for about 215 m with a 3% slope down to el. 1026.8. Then a chute with terminal flip bucket is provided at the outlet of each tailrace tunnel, bringing the water down to el. 1000 m a.s.l. Deflector blocks are provided on the buckets in order to obtain a favorable jet trajectory and reduce scouring in the Vakhsh River.

### 3.2 Hydraulics of the Middle Level Outlets

#### Tunnel Pressure Stretch

The upstream reach of the tunnels up to the sector gate chambers will operate normally under pressure conditions.

For MLO1, the water discharge reaches 3,685 m<sup>3</sup>/s for an exceptional maximum head of 150 m. For the dam alternative with FSL=1,220, the maximum head is 140 m and the corresponding flow 3,564 m<sup>3</sup>/s. The individual flow of each branch is 1,843 m<sup>3</sup>/s for FSL=1,290 m a.s.l, which is adopted as a design discharge for all dam alternatives.

For MLO2, the water discharge reaches 3,710 m<sup>3</sup>/s for a head of 150 m. The discharge is equally divided between the two vortex shafts in this case, corresponding to 1,855 m<sup>3</sup>/s each.

The water velocity in the culvert of MLO1 is of 13.2 m/s, rises up to 21 m/s in the tunnel, goes up to 30 m/s in the conduits of the gates, and 41 m/s at the same gates section.

#### Tunnel Free-flow Stretch

The water surface profiles in steady flow conditions have been computed with the same approach as to that of DT3, adopting the STEFLO software to implement the model.

Considerations similar to these discussed for DT3 with respect to the possible problems and measures implemented in order to avoid, or at least mitigate, them were made for the middle level outlets, by adopting a 4° angle transition downstream from the gates and steel lining along the conduits and transitions. An aeration system was also designed, consisting of ventilation ducts and enlargements of the section downstream from the gates section and in the floor for bringing air below the jet.

According to empirical analyses, the air demand for the carrying capacity corresponds to approximately 22% of the water discharge when there is a velocity of 41 m/s at the gates section.

The dimensions of the free-flow tunnel cross section guarantee a sufficient freeboard for a good aeration and for shock wave control.

### Vortex shaft

The vortex shaft spillway is made up of the spiral-shaped vortex inlet structure, the drop shaft and the tailrace tunnel. With the geometry adopted for the vortex inlet, the water spirals down clinging to the wall of the drop shaft with significant energy dissipation.

Vortex drop shafts are being adopted in a number of projects in view of the advantages obtained in controlling effectively the water velocity and dissipating energy, even though in general, the flows are not as high as in the Rogun project. The most important project which adopted the vortex swirl approach is the Tehri Dam Project, with four shaft spillways. The hydraulic characteristics of the tunnels are:

- Two gated left bank shaft spillways (T1, T2) designed for a total discharge capacity of 3,800 m<sup>3</sup>/s.
- Two un-gated, right bank shaft spillways (T3, T4) designed for a total discharge capacity of 3,900 m<sup>3</sup>/s.

The inlet design proposed by TEAS Consultant is based on a spiral vortex inlet for supercritical approaching flow proposed by Hager, based on model tests carried out in the Laboratory of Hydraulics, Hydrology and Glaciology (VAW) of the Swiss Federal Institute of Technology (ETH) in Zurich.

Based on the mentioned approach, a diameter of the drop shaft of 14.0 m was adopted for a design discharge of approximately 1,800 m<sup>3</sup>/s.

With this solution, most of the air entrained in the flow down the helicoidal stream is ejected from the swirling flow at the bottom of the shaft, thus minimizing the need for aeration.

The amount of air entrained into the flow was determined with the empirical equation proposed by Kalinske & Robertson. An air conduit with a diameter of 2.5 m was assumed, which is compatible with an air discharge of 50 m<sup>3</sup>/s, with an average velocity of 10 m/s.

The tangential flow rotation represents a source of potential cavitation in vortex spillways, thus steel lining in the bottom of the drop shaft is necessary, and adequate measures have to be implemented in order to improve the capability of the concrete lining to resist potential erosion phenomena.

### Flip Bucket

For MLO2, the jet trajectories corresponding to different angles examined (30°, 25° and 20°) were calculated for the flow of 1843 m<sup>3</sup>/s, by applying the USBR formula that gives the trajectory of the lower nappe of the jet: the average horizontal distance of the point of impact of the jet with respect to the flip bucket is approximately 118 m for the discharge 1850 m<sup>3</sup>/s and 97 m for 1065 m<sup>3</sup>/s.

In consideration of the trajectory length and the impact area in respect to the outlet location, 20° was selected as take-off angle of the flip buckets.

### Plunge Pool

The field of variation of the scour depth  $D = t + h$  obtained by application of empirical formulae, is between 34 and 62.6 m, while the average value is 47 m for the discharge 1850 m<sup>3</sup>/s. For the 1065 m<sup>3</sup>/s discharge,  $D$  is between 23.4 m and 43.4 m, with an average of 33 m.

Also in this case, in order to assess the results of the empirical formulae, the pressure bulb theory for the discharges of 1850 m<sup>3</sup>/s and 1065 m<sup>3</sup>/s and a take-off angle of 20° was applied.

Considering a pressure value of 15 T/m<sup>2</sup> (1.5 kg/cm<sup>2</sup>) as an erodibility threshold, this value is reached at a distance of 27 m along the axis of the bulb for the 1850 m<sup>3</sup>/s case, while for the 1065 m<sup>3</sup>/s case this happens at 15 m.

In this situation, a pre-excavation of about 20 m from the tailwater level at elevation 980 m a.s.l. would be adopted.

## 4 MULTI-LEVEL INTAKES

As a possible solution for mitigating the sedimentation effect with a relatively low cost, the implementation of a multi-level intake solution is proposed, with the possible additional aim to draw turbidity currents into the power inlets.

The multi-level intakes, with withdrawal velocities higher than the turbidity currents velocity, are provided with steel elements for closure. In principle the withdrawal intakes of the venting system should be located as low as possible in the reservoir.

The preliminary design of the intakes considers a concrete culvert some 16.0 m wide and 12.0 m high. The cross sectional area is 156 m<sup>2</sup> and the water velocity inside the duct for a 270 m<sup>3</sup>/s flow is about 1.73 m/s, which provides negligible head losses. Water velocity through the intakes openings (preliminarily 6.50 m wide by 8.25 m high each, two openings each intake) is in the order of 2.52 m/s.

The total additional head losses could be in the order of 0.40 m, which is a value lower than the range of precision that can be obtained when the whole power waterways head losses are calculated. Model studies can allow improving the hydraulic behavior of the system and reducing the head losses at the detailed design stage.

The power waterways inlets proper would be provided with removable trashracks similar to these already foreseen at the power intakes of the solution proposed by HPI.

Also the culvert multi-level intakes would be provided with removable trashracks featuring widely spaced bars, the only purpose of which is to prevent entry of large floating bodies into the culvert. The intakes would be provided with steel elements for closure, in order to exclude these inlets that will be progressively submerged by the sediments deposit. These elements are not required to ensure watertightness and will be operated under water pressure balanced conditions only.

## 5 HIGH LEVEL TUNNEL SPILLWAYS

### 5.1 Overview of the High Level Tunnel Spillways

The number of high-level tunnel spillways for each alternative was indicated above, in paragraph 1.5.

For alternative FSL = 1,290 m a.s.l., the intake of High Level Tunnel Spillway 1 (HLTS1) is set at el. 1,190 m a.s.l.; the tunnel is composed of a pressure stretch, the maintenance gate chamber, the sector and emergency gate chamber and a free flow stretch.

From the tunnel outlet portal, the cross section diverges to a width of 30 m through a chute with a slope of 45° between el. 1,177.7 and 1,130.0, followed by a stilling basin, 30 m wide and 65 m long. At the end of the stilling basin, a 9.5 m high sill is foreseen.

A second chute and a second stilling basin follow, with the same geometrical features, and a final chute brings the flow down to a terminal flip bucket at el. 1,000 m a.s.l., with a take-off angle of 30°.

High Level Tunnel Spillway 2 (HLTS2) shows the same features and intake elevation as HLTS1, albeit the gate chambers are located at a distance from the intake somewhat different to that of HLTS1 as a consequence of the slightly different route.

As with the previous tunnel, the cascade system is composed of three chutes and two stilling basins; the only difference is with the elevations of the tunnel portal and the stilling basins, since the cascade has been adapted to the morphological conditions found along the alignment.

For the other alternatives, all general features of the tunnels are identical, with the usual cross sections and facilities and the configuration of the chutes and stilling basins is repeated.

The tunnel pressure stretch shows a horseshoe cross-section of 10 m in diameter and has a slope of 0.75 %. Maximum water velocity is close to 20 m/s. At the end of this reach, the tunnel presents a transition to a 16.5 m wide and 5.15 m high rectangular cross section, where the emergency and sector gate chamber (about 136 m long) is located. It is equipped with three slide gates and three sector gates. The water velocity in the gates' conduits is 29.3 m/s, and 32 m/s at the gate section. The conduits of the gate chamber and adjacent stretches of the transitions are steel lined.



The maintenance gate chamber, located about 250 m from the tunnel intake, is equipped with two slide gates. Steel lining is foreseen with the same configuration adopted for the emergency and sector gate chamber.

Downstream from the emergency and sector gate chamber, the tunnel converges to a 10 m wide and 12 m high D-shaped free-flow tunnel, with a slope of 1.0 %.

Downstream from the outlet portal, the cascade system is as described above.

## 5.2 Hydraulics of the High Level Tunnel Spillways

The aim of the high level tunnel spillways is to ensure flood control and avoid overtopping during the final phase of dam construction, and during plant operation.

The hydraulic analyses were focused on the alternative with FSL = 1,290 m a.s.l, but the results can be extrapolated to all the other situations of operation and alternatives.

According to the calculation methodology presented for diversion tunnel 3, for this alternative the maximum discharge with the gates fully open is 1,570 m<sup>3</sup>/s.

The problems that were mentioned while analyzing the free flow reach behavior of the other hydraulic facilities are also taken into account here, and the same mitigation measures are implemented, i.e. upstream and downstream transitions with low deviation angles, normally lower than 4°, adequate freeboard and aeration system.

For the design discharge, if the uniform flow condition is considered, the freeboard is about 35% of the total section height and water velocity is about 18 m/s.

### Cascade System

The free flow cascade system was verified for the scenarios with a higher head between the tunnel outlet portal and the riverbed.

The curves of the spillway are designed like these of the uncontrolled ogee crest in subcritical condition, as in the case of a Creager spillway, while the stilling basins design was carried out based on the recommendations of the US Bureau of Reclamation (USBR), as described by Peterka, and from the Saint Anthony Falls Hydraulics Laboratory (SAF), Blaisdell, Hager and Sinniger and Hager and Bretz.

The limit condition to form a jump entirely before the positive step was verified as proposed by Hager and Bretz, and the length of the jump was calculated from the equation of the length of the uncontrolled jump recommend by Hager and Sinniger, obtaining a maximum length of about 100 m. The design adopted 65 m long stilling basins, corresponding to about two third of the maximum jump length, which is considered acceptable on account of the fact that the strongest rate of energy dissipation occurs in the first half of the hydraulic jump length.

The basin dimensions were then verified with the STEFLO mathematical model.

The following criteria have been adopted in designing the structures of the discharge system: the velocity of the flow along the system must not be higher than 40 m/s, the maximum head of the chutes is 75 m and the slope is not higher than 45°.

The maximum ratio between the energy losses and the potential energy is 85%.

#### Flip Bucket

The jet trajectories, taking into account an angle of 30° for High level tunnels 1 and 2 of alternative FSL = 1,290 and High level tunnel 3 of alternative FSL = 1,255, have been calculated for the maximum discharge of 1,570 m<sup>3</sup>/s by applying the USBR formula that gives the trajectory of the lower nappe of the jet, finding that the impact occurs at distances from the lip of the flip bucket of 102, 101, and 84 m respectively.

#### Plunge Pool

The depth of erosion is evaluated by making use of the same methodology mentioned for the Diversion Tunnel n°3.

For HLTS1 and HLTS2, FSL=1290, the field of variation of the scour depth  $D = t + h$  obtained by the application of empirical formulae is between 21.5 and 41.6 m, while the average value is 31.5 m for the discharge of 1570 m<sup>3</sup>/s. For 1000 m<sup>3</sup>/s discharge, D is between 17.1 m and 32.5 m, with an average of 24.5 m.

For HLTS3, 1255 m a.s.l., the field of variation of the scour depth  $D = t + h$  obtained by the application of empirical formulae is between 19.2 and 38.8 m, while the average value is 29 m for the discharge of 1490 m<sup>3</sup>/s. For 1000 m<sup>3</sup>/s discharge, D is between 15.6 m and 31.2 m, with an average of 23 m.

Considering, also in this case, a pressure value of 15 T/m<sup>2</sup> (1.5 kg/cm<sup>2</sup>) as an erodibility threshold, this value is reached at a distance of 13 m along the axis of the bulb for the 1570 m<sup>3</sup>/s case, while for the 1000 m<sup>3</sup>/s case this happens at 8 m.

In this situation, given the head and the specific discharge, the plunge pool pre-excavation would not be strictly necessary. However, since the falling jet is impacting on the right bank of the river, measures to protect the same bank and avoid instability of the outlet structures are proposed.

These measures consist in pre-excavating the possible scouring area down to el 970 m a.s.l. for a width equal to 1.5 times the flip bucket and to protect the bank with a concrete structure constituted by a grid of beams and a slab 1 m thick laying on the excavation slope, anchored to the rock by tendons. A terminal cut-off some 8 m deep is foreseen at the lower end of the protection structure, reaching a depth of almost 25 m below the original ground surface.

## 6 SURFACE SPILLWAY

### 6.1 Design Criteria and Calculations

The surface spillway, which would replace in the long term the other flood evacuation facilities planned for the beginning of the useful life of the project, must be designed for a discharge capacity equal to the peak discharge of the Probable Maximum Flood (PMF).

It has to be operational when the sediment load in the reservoir affects the discharge capacity of tunnels having low level intakes and is to be designed in such a way that possible erosion damages caused by sediments can be easily repaired by isolating part of the spillway.

At the beginning of the design process, the possibility to implement simple gated sills followed by a chute channel was analyzed, as well as a cascade scheme formed by a sequence of chutes and sub-horizontal channels.

However, considering the very high head between the sills and the riverbed, neither of the two solutions turned out to be acceptable, due to the very high water velocity in the terminal structure and to the cavitation indices, which were lower than 0.1.

With the aim to raise the cavitation indices to a value superior to 0.2, flow velocity is to be lowered. This can be achieved by dissipating energy every time that it reaches a tolerable limit value. It is done by adopting a combination of chutes and stilling basins. Cavitation indices in the range of 0.1 to 0.2 may still be acceptable provided that adequate anti-cavitation measures (such as aerators) be implemented.

The final scheme consists of a three-step cascade with intermediate energy dissipation, ending with a flip bucket.

### Configuration

The area where the surface spillway was placed is not aligned with the gradient (maximum slope) of that bank, providing enough space for placing the intermediate energy dissipators mentioned previously. Based on preliminary cost estimates of the possible alternatives, it was decided to cross the rock heights with a tunnel rather than excavating an open-air channel.

### Approach Bay

In order to avoid affecting the riprap blocks of the upstream face of the dam, a minimum distance of 50 m was left between the axis of the dam crest and the closer side of the approach bay.

Alternatives with an approach bay leading to four conduits or to only three conduits have been analyzed. The conduits are constituted initially by a tunnel crossing the rock heights between the reservoir and the river, and by a chute channel to lead the water down to the river.

The volume of excavation for the alternative with four “conduits” is significantly larger than for the alternative with three conduits, with a width of 68 m each, which is preferred.

### Gated Sills

The evaluation of the discharge capacity of the surface spillway followed the methodology proposed by the USBR.

Taking into account the fact that this spillway is to be designed for long term conditions, when the reservoir has lost its regulating capacity, the design discharge is to be adopted equal to the peak of the Probable Maximum Flood without any reservoir routing effect, i.e. 8,160 m<sup>3</sup>/s.

The design also takes into account the “N-1” or “N-2” condition: i.e., the capability to discharge the flood with a mean period of return of 10,000 years, assuming that one (or two, if N>6) out of the “N” gates cannot be opened. The peak daily discharge of the 10,000-year flood is 5,970 m<sup>3</sup>/s.

These floods are to be discharged under the elevation of the top of the dam core, which is placed 3.75 m below the dam crest elevation for each of the three alternatives.

Three independent approach bays and “conduits” had been adopted ( $N_C=3$ ). For each of them, four spillway bays ( $N_C=4$ ) with a width of 8 m have been adopted.

With the above-mentioned spillway characteristics, the instantaneous peak discharge of the PMF (8,160 m<sup>3</sup>/s) is evacuated under a head of 11.96 m. The crest of the spillway sills are then placed in such a way that a margin of 0.25 m with respect to the top of the dam core is left.

### Tunnel Reach

Each one of the three “conduits” includes a free flow tunnel reach.

For a safe design, the minimum separation between contiguous tunnel axes will be three times the equivalent tunnel diameter. This condition, on account of the total available width of 68 m for each “conduit”, together with considerations related to normal technological and economic construction conditions, led to select a layout with two tunnels.

### Chute and Intermediate Energy Dissipation

The chute channel leads water from the tunnels with free surface flow to the ski-jump structure and eventually back to the river, with a total head of about 200 m.

The proposed system of controlling water velocity and cavitation indices consists in a cascade of sub-horizontal reaches where stilling basins are placed after every 70 m of chute. This way the water velocity is kept below 40 m/s and cavitation index between 0.1 and 0.2.

The effective length of the basin adopted is two thirds of the theoretical length of the hydraulic jump, on account of the fact that the strongest rate of energy dissipation occurs in the first half of its length, and aerators have been provided in the intermediate chutes in order to minimize cavitation damages induced by the high velocities.

For the dam alternative with FSL = 1,220 only two of the three steps will be used for the chute system of the spillway, while for the dam with FSL = 1,255 the height of each step will be reduced by 12 m, 12 m and 11 m, respectively.

#### Ski Jump and Plunge Pool

The calculation of the trajectories aims at evaluating the viability of the ski-jump solution, by checking if the jet falls in the desired area (generally the riverbed), as well as its main hydraulic parameters, so as to verify the viability of the plunge pool.

The analyses performed confirm the correct location of the plunging jet with respect to the stability of the banks and the potential development of the plunge pool. The falling jet enters the riverbed with a horizontal angle of some 45°, by adjusting the geometry of the terminal structures, the impact area can be extended so as to reduce the specific discharge and the depth of scour.

The opposite bank shows a flat platform in front of the spillway axis, which provides additional margin for the development of the plunge pool without endangering the stability of the left bank.

The field of variation of the scour depth  $D = t + h$  obtained by application of empirical formulae, is between 34.2 and 73.2 m, while the average value is 51 m. This value is for a single chute.

It is to be noticed that this is the value resulting from the use of the peak discharge of the PMF as a permanent value. Taking into account the short duration of the peak of the PMF and using the

persistent value of 4,000 m<sup>3</sup>/s, a new global average of 35 m (minimum 22.9 and maximum 52.4 m) is found. This value is to be read as h=20 m of water cushion plus t=15 m of true scour.

The methodological approach based on the assessment of the hydrodynamic pressure of the underwater jet, was applied for the discharge 7800 m<sup>3</sup>/s concerning the PMF with specific discharge of 79 m<sup>3</sup>/s/m corresponding to a single chute. The footprint of the impact area for three chutes is about 200 m.

Considering also in this case a pressure value of 15 T/m<sup>2</sup> (1.5 kg/cm<sup>2</sup>) as an erodibility threshold, this value is reached at a distance of 30 m along the axis of the bulb. In this situation, a pre-excavation of the above cited dimensions, is compatible with the dynamic pressures identified along the axis of the bulb adopting the method proposed by Hartung and Häusler.

The pre-excavation of part of the plunge pool has been envisaged, in order to avoid possible formation of dunes and consequent inundation of upstream structures.

## 6.2 Conclusions and Recommendations

The feasibility of a surface spillway with a discharge capacity equal to the peak of the PMF has been established. This facility has to replace the other flood evacuating organs once the sediments in the reservoir prevent their use or reduces their discharge capacities.

Without the provision of a surface spillway, the entire project would have to be dismantled in a mid-term future, or simply not constructed at all.

The spillway structure consists of three independent conduits with the following components:

- Approach bays with control sills provided with four gated bays (the total number of bays is  $3 \times 4 = 12$ ).
- Sub-horizontal free flow tunnels excavated through the high hill on the right bank.
- Open-air stepped chute channels. Each step is 70 m high and consists of a steep chute followed by a stilling basin. There are three steps in the two higher dam alternatives and just two steps in the smallest one.
- A flip bucket at the end of the last chute and a plunge pool in the riverbed.

All components use state-of-the-art designs and dimensions, and have proved feasible. Model tests are recommended.



## CHAPTER 3.3: APPENDIX 5 – PMF MANAGEMENT

### 1 INTRODUCTION

The present Appendix 5 to the Chapter 3 “Alternatives Design” is an evaluation of the possible options for the management of the Probable Maximum Flood (PMF) for the different dam height alternatives.

As outlined in the design criteria of the project, the primary objective is that the dam must be self-protected against the PMF (no overtopping of Rogun Rockfill dam can be envisaged even in case of extreme floods).

Therefore, the first step of this appendix 5 will be to evaluate the protection provided to the dam in the project elaborated by HPI, and, if this protection is considered not satisfactory, to propose alternative solutions.

Then, given the storage capacity of Rogun reservoir and its flood attenuation capacity, this appendix 5 will evaluate the possibility of releasing from Rogun flows acceptable for Nurek dam.

A special attention has been paid in this report to the spillway arrangement necessary during the operation life of the power plant and on the long term in order to provide a full protection of the dam against the PMF. It appears that, whatever the solution implemented and due to the sediments that will be accumulated in the reservoir, it is mandatory that, on the long term, a surface spillway is made available to ensure the safe evacuation of the PMF without overtopping of Rogun dam.

The scope of the present appendix is to identify suitable solutions to, first, protect Rogun against high flood, and then, protect the cascade, for the three dam height alternatives, with Full Supply Levels at elevations 1290 masl, 1255 masl and 1220 masl,

## 2 BASIC CONSTRAINTS

### 2.1 Design Criteria

As stated in the Chapter 1 of Volume 3 “Design Criteria”, the following conditions have to be met for the 10 000 year return flood and the Probable Maximum Flood (PMF).

These floods are to be discharged under the elevation of the top of the dam core. Dam core top elevation is placed 3.75 m below the dam crest elevation for all the three alternatives of full supply level.

That condition is indeed the governing condition, because:

- Wind waves concomitant with the PMF and the one-in-10,000-year flood are not significant. Indeed, assuming a low combined probability of occurrence of floods and winds, winds supposed to occur simultaneously with high floods are frequent winds thus generating small waves.
- Long term dam settlement is supposed to have been compensated with an equivalent dam crest chamfer.
- GLOFs (glacial lake outburst floods) are unlike to happen simultaneously with the peak of the design floods. Indeed, the volume of glacial lakes may be related to persistent high temperatures (as in the case of high floods) but the outburst triggering causes are to be related also with mass movements and seismicity. Mitigation measures can also be envisaged.

Assuming  $N$  orifice spillways and  $n$  gates for the surface spillway (for  $n=0$ , the surface spillway is a free-overflow spillway):

- for the 10 000 year flood, either with  $N-1$  orifice spillways or with the  $n-1$  gates of the surface spillway(s) ( $n-2$  if the number of gates is more than 6), the maximum water level should be not higher than the top of the dam core. Note that it is the tunnel with the largest expected discharge which should be considered as being not in operation.
- For the PMF, with the  $N$  orifice spillways and the  $n$  gates of the surface spillway, the maximum water level should be not higher than the top of the dam core.

## 2.2 Floods considered

The reference floods considered for the protection of the Rogun dam, whatever is the selected alternative, are the PMF and the 10 000 year return period flood as stated in the Design Criteria.

## 2.3 Safety principles on flood management

In addition to the design criteria stated above, the following safety principles are taken into account:

**Turbine operation:** The PMF is an exceptional extreme event during which the normal operation of the power plant could be dangerous or unavailable. Therefore, the turbines cannot be considered as a spilling facility in the overall spillage capacity of Rogun during the peak period of the PMF, which has been defined as starting on day 180 with duration of 3 weeks.

- **Flood forecasting:** as Rogun is under a snow and ice melt regime, it is possible to forecast high flood by monitoring the amount of snow accumulated during the previous winter. The analysis performed here considers that it is possible to forecast the flood and take appropriate measures (lower reservoir level for instance) before occurrence of a high flood event.
- **Type of spillways:** The Consultant's practice and recommendation is not to rely on tunnel spillways only: they are subject to operational and maintenance issues and they are not flexible with respect to any variation above the design discharge. For a given increase in head, the incremental discharge capacity is much lower for a tunnel spillway than for a surface spillway. This gives an important constraint to the flood evacuating system. This allows little uncertainty around the design discharge adopted and little possibility of adapting the system to future trends in design floods (climate change...).
- **Discharge facilities:** All discharge facilities shall be independent: One accident on one of them shall not impact any of the other devices.

- **Tunnels and fault crossing:** Tunnels crossing faults might be damaged because of fault movements during large earthquakes or due to accumulation of creeping. This can result in the unavailability of the said tunnel. Therefore, it is recommended to avoid fault crossing as much as possible or, when impossible to avoid such crossing, to adopt a special design to sustain the displacements and maintain the integrity of the structure.

## 2.4 Nurek design feature

In the original design of HPI, the turbines of Nurek Powerplant are considered in the total flood evacuation capacity of the project. The spillage capacity considered by original designers at Nurek was 4 040 m<sup>3</sup>/s (spillways) + 1 420 m<sup>3</sup>/s (turbines). As stated above, the Consultant does not consider the powerplant as a spillage device during the peak period of the PMF. The discharge capacity considered by the consultant at Nurek is 4 040 m<sup>3</sup>/s during the peak period of the PMF and 5 400 m<sup>3</sup>/s out of the peak period of the PMF. The spillage capacity is provided by two structures: one bottom spillway set at elevation 857 masl and one surface spillway set at elevation 897 masl. Each spillway has a capacity of 2020 m<sup>3</sup>/s when the reservoir level is at elevation 910 masl.

## 3 ANALYSIS OF THE SOLUTION PROPOSED BY HPI

### 3.1 Description of HPI solution

In the solution proposed by HPI in the 2009/2010 study, the spillways arrangement for the dam at elevation 1300 masl (FSL 1290 masl) is the following:

- 3<sup>rd</sup> operation spillway (OP3): it is a tunnel spillway with intake at elevation 1145 masl, some 400 and 600 m long, it splits into 2 branches. Each branch includes a vertical vortex shaft ended with a vortex device that dissipates a large part of the energy. The final tunnel stretch is horizontal and ended with a flip bucket set up a few meters above the river.
- Remote spillway (RS): it is a tunnel spillway with intake at elevation 1145 masl, some 400 and 600 m long. The final tunnel stretch is horizontal and ended with a flip bucket set up a few meters above the river.

- Operation shaft spillway: it is an overflow spillway, with a circular entrance equipped with 3 radial gates 14 m wide, the elevation of sill is at 1283.5 masl, this entrance is connected to a shaft 12m diameter which is connected to the same shaft as the remote spillway. Shortly above the connection with the remote spillway, the normal section of the shaft is reduced to a throttled section with a diameter of 9.2 m, which acts as control point for larger discharges (“throat control”), i.e. energy dissipation would take place in the shaft above the throttle.



**Figure 35 : 3rd operation spillway - longitudinal section**

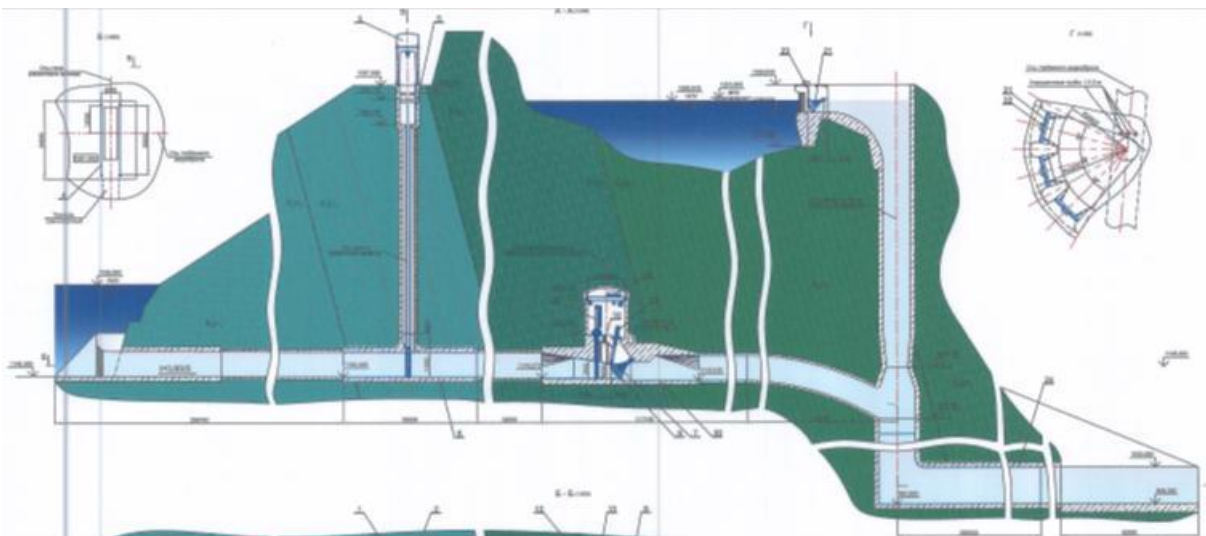

**Figure 36 : Remote spillway and Operation shaft spillway - longitudinal section**

The total spillage capacity is 7 100 m<sup>3</sup>/s, that is to say the value of PMF as estimated in HPI study.

The next graph presents the discharge capacity of the three operation spillways designed by HPI.

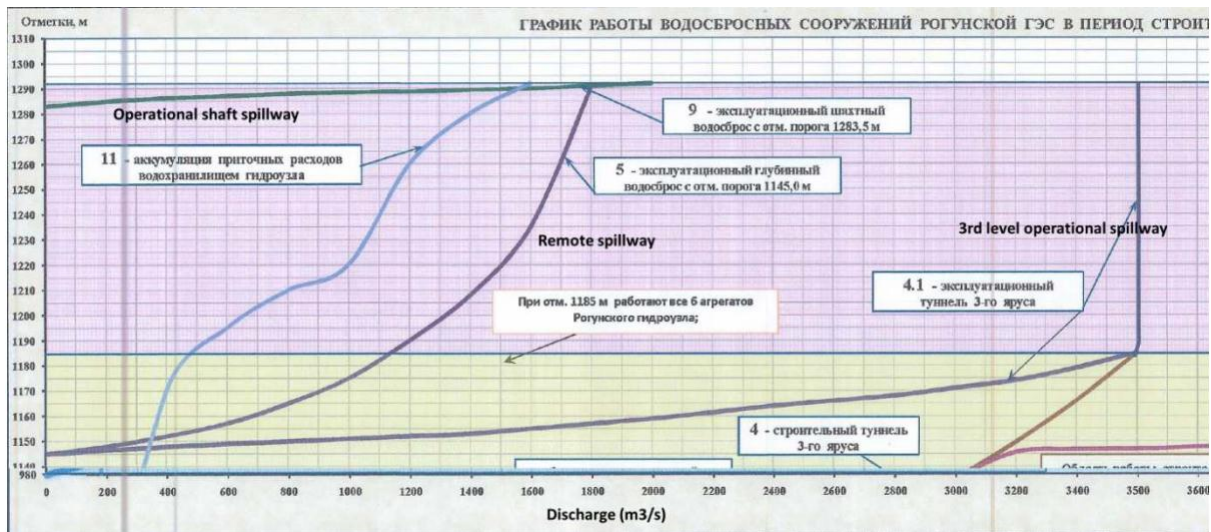

Figure 37 : Extract of HPI studies - spillways discharge capacity versus reservoir elevation

### 3.2 Analysis of the solution with respect to the basic constraints

It has been shown in the present study that the solution proposed by HPI suffers from several drawbacks:

- Maximum head on the tunnels is beyond the value recommended by the Consultant.
- Necessity to re-design the distribution of flow between the spillways in order to meet the N-1 criterion.
- Two devices sharing the same outlet.
- Lack of experience for such high capacity of vortex facilities for permanent flood evacuation facilities.
- Long term flood discharge facilities are not provided in HPI design.

The Consultant considers that safety requirements are not met. Therefore, other options are studied in the rest of the present appendix in order to select the appropriate solution for each dam height.



## 4 ROGUN PROTECTION AGAINST HIGH FLOODS

### 4.1 Spillways available at the end of construction

As discussed in the Chapter 3.3 - Appendix 3 “Flood Management During Construction”, the following tunnel spillways remain available at the end of construction as high level spillway for each dam height alternative:

Dam alternative	Number of tunnels available	Number of gates per tunnel	Intake elevation of tunnels
FSL = 1220 masl	1	3	1140 masl
FSL = 1255 masl	3	3	1 at 1145 masl and 2 at 1165 masl
FSL = 1290 masl	2	3	1190 masl

**Table 50 : high level spillways available at the end of construction**

It is to be noted that for the alternative FSL = 1290 masl, the Mid Level Outlet 2 (MLO2) should not be affected by sediments for about 50 to 60 years. Therefore, it could be used as an additional outlet in case of PMF.

### 4.2 Possible types of spillway

As described in the Chapter 3.3 - Appendix 4 “Hydraulics of the Project Components”, technically feasible solutions have been found for both surface spillway and pressured tunnel type spillway.

Tunnel spillways would have the same features as the tunnels available at the end of construction described in 4.1 above.

It is to be noted that the surface spillway is the kind of facility necessary on the long term when the reservoir will be filled with sediments to ensure the long term sustainability of the project. The surface spillway, as presented in the Volume 3, Chapter 3, Appendix 4 “Hydraulics of the Project Components”, is made of three independent waterways. This modular design allows building only

part of the spillway during the dam construction and completing it when required. One module of surface spillway would have the following features:

Dam alternative	Number gates per waterway	Width of the gates	Sill Elevation
FSL = 1220 masl	4	8m	1214 masl
FSL = 1255 masl	4	8m	1249 masl
FSL = 1290 masl	4	8m	1284 masl

**Table 51: Surface spillway main features**

### 4.3 Parameters impacting the performance of the flood management

**Flood attenuation capacity:** The effect of sedimentation on the flood routing capacity of the reservoir has been duly taken into account, using the reservoir capacity curves derived in the chapter on sedimentation. The analysis has been carried out at 40 years after the Stage 1, which is consistent with the period considered in the economic analysis. However, it is to be noted that for the alternative FSL = 1220 masl, 40 years after the river diversion, the intake of the tunnel spillways is below the level of sediments. Therefore, for the alternative FSL = 1220 masl, results are given at 30 years after river diversion which corresponds to the end of operation of the tunnel spillways.

**Elevation in the reservoir at the beginning of the flood:** The analysis performed here considers that it is possible to forecast the flood and take appropriate measures (lower reservoir level for instance) before occurrence of an extremely high flood event.

**Number of gates of tunnels available:** As mentioned earlier, tunnels can be subject to maintenance and operation difficulties. It is therefore important to evaluate the impact of non-availability of gates on the discharge capacity during floods. This potential loss of discharge capacity can be balanced by either a raise of the dam crest or a surface spillway made available. In case of additional surface spillway, the number of surface spillway gates to be opened needs to be evaluated. This sensitivity analysis has been carried out in the present analysis.



#### 4.4 Conclusion on the protection of Rogun against the PMF

For the alternative FSL=1220 masl, four solutions are technically suitable for the protection of Rogun dam. Among them, the solution with 1 tunnel, 2 modules of surface spillway and a dam crest rise by 1,5m is the least expensive solution.

For the alternative FSL=1255 masl, the protection against the PMF is satisfactory with the 3 tunnels necessary for the construction and 1 module of surface spillway.

For the alternative FSL=1290 masl, the protection against the PMF is satisfactory with the 2 high level tunnels and the mid-level outlet necessary for the construction and 1 module of surface spillway.

### 5 VAKHSH PROTECTION AGAINST HIGH FLOODS

As stated in the introduction: Rogun shall be self-protected against high floods during its whole life span and this is the base design studied in the previous paragraphs. However the possibility of protecting Nurek against high floods in specific conditions could be an additional service provided by Rogun. This opportunity is studied in the following section for the three dam alternatives.

#### 5.1 Spillways available at Nurek

2 spillways are available at Nurek:

- 1 tunnel spillway with intake at about 810 masl and a capacity of 2020 m<sup>3</sup>/s for a water level in the reservoir at 910 masl.

- 1 gated surface spillway with 2 gates, sill at 897,3 masl and a width of 12 m each. This surface spillway is followed by a tunnel 10 m wide and 11 m high. The capacity of this spillway is given as 2020 m<sup>3</sup>/s for a water level in the reservoir at 910 masl.

As for Rogun, the Consultant recommends not to consider the turbines capacity in the spillage capacity during the peak period of the flood. Therefore, the maximum evacuation capacity without turbines is given as 4040 m<sup>3</sup>/s. The discharge capacity through the turbines is 158 m<sup>3</sup>/s x 9 turbines. Therefore, with turbines, the discharge capacity at FSL in Nurek is 5 462 m<sup>3</sup>/s.

## 5.2 Cascade protection requirements

Nurek and the downstream cascade are designed to handle a flood lower than the PMF. Rogun project implementation can be the opportunity to protect the cascade against PMF by limiting the discharge downstream of Rogun to a level acceptable for the downstream structures.

As said above Nurek spillway design discharge is 4040 m<sup>3</sup>/s and 5462 m<sup>3</sup>/s including the turbines.

The Consultant noted during the course of the study that the water velocity in the Nurek surface spillway is high: 55 m/s. The matching cavitation index is at 0,08 at the end of the first stretch of the tunnel (change of slope).

A cavitation index below 0,1 is considered not acceptable in international standards. The Consultant understands that mitigation measures have been implemented to bring this cavitation index up to acceptable values. However these are not known by the Consultant, so the adequacy of these measures for a flow increase is not known.

Therefore, the restriction considered in the present chapter is that discharge through the Nurek surface spillway should not overpass its design value 2020 m<sup>3</sup>/s. Consequently, the Nurek reservoir level should not be higher than 910 masl.

The Consultant assumes that the hydropower plant located downstream of Nurek are designed to handle at least the same discharge as Nurek. Therefore, the limitation in Nurek discharge is a criteria that ensures the protection of the entire Vakhsh cascade.

## 5.3 Conclusion on the management of high floods

### Alternative FSL = 1220 masl

For this alternative, 3 options meet the criteria defined in paragraph 2 “Basic Constraints”. Out of these options, none is able to provide a protection to Nurek with a flow released through Nurek surface spillway in the range of its design value.

The closest solution for Nurek protection is to have 3 tunnels and a surface spillway at Rogun and a dam crest raised to at least 1251 m a.s.l.

### Alternative FSL = 1255 masl

For this alternative, the solution chosen at Rogun attenuates the flow enough so that the maximum water level and the maximum flow in the surface spillway meet the values required.

### Alternative FSL = 1290 masl

For this alternative, the solution chosen at Rogun attenuates the flow enough so that the maximum water level and the maximum flow in the surface spillway meet the values required.

## 6 CONCLUSION AND RECOMMENDATIONS

### Alternative FSL = 1220 masl

Three options have been found to provide an acceptable protection to Rogun. The least expensive option, and the recommended one, is to have 2 modules of the surface spillway, 1 tunnel and a crest rise of 1.5 m.

Out of these three options, none can be reasonably adapted to also protect Nurek and the cascade. The closest solution could be to have the dam crest raised to at least 1251 m a.s.l.

The maximum levels in the reservoirs and maximum flows are the following:

t=30 years	Maximum levels	Maximum Outflows
Rogun during the PMF	1226.4 masl	7496 m <sup>3</sup> /s
Rogun during the 10 000 years flood	1227.9 masl	5427 m <sup>3</sup> /s
Nurek during the PMF	916.6 masl	6223 m <sup>3</sup> /s
Nurek during the 10 000 years flood	900.1 masl	3485 m <sup>3</sup> /s

### Alternative FSL = 1255 masl

The solution with the 3 tunnels necessary for the construction complemented by 1 surface spillway provides an acceptable protection of Rogun against the PMF and the 10 000 years return period flood.

When a potential high flood is detected, a partial closure of one tunnel allows controlling and attenuating the flood in Rogun, and provides a protection to Nurek and the downstream facilities.

The surface spillway at Rogun is compulsory in order to face the unavailability of gates in the tunnels.

The maximum levels in the reservoirs and maximum outflows are the following:

<b>t=40 years</b>	<b>Maximum levels</b>	<b>Maximum outflows</b>
Rogun during the PMF	1262,0 masl	4380 m <sup>3</sup> /s
Rogun during the 10 000 years flood	1232,5 masl	3614 m <sup>3</sup> /s
Nurek during the PMF	910,0 masl	5351 m <sup>3</sup> /s
Nurek during the 10 000 years flood	901 masl	3587 m <sup>3</sup> /s

#### **Alternative FSL = 1290 masl**

The solution with the 2 high level tunnels and the mid-level outlet necessary for the construction complemented by 1 surface spillway provides an acceptable protection of Rogun against the PMF and the 10 000 years return period flood.

When a potential high flood is detected, a partial closure of one high level tunnel and the opening only one gate of the mid-level outlet allow controlling and attenuating the flood in Rogun, and provide a protection to Nurek and the downstream facilities.

The surface spillway is compulsory in order to face the unavailability of gates in the tunnels.

In addition, the Consultant recommends reviewing in detail the design of Nurek surface spillway during the next phases of the studies in order to make sure that no damage will occur even at its design flow.

The maximum levels in the reservoirs are the following:

<b>t=40 years</b>	<b>Maximum levels</b>	<b>Maximum Outflows</b>
Rogun during the PMF	1291,9 masl	4828 m <sup>3</sup> /s
Rogun during the 10 000 years flood	1278,9 masl	3394 m <sup>3</sup> /s
Nurek during the PMF	910,1 masl	5389 m <sup>3</sup> /s
Nurek during the 10 000 years flood	895,9 masl	3292 m <sup>3</sup> /s

It has been decided, during the course of the study, to make Rogun a multi-purpose dam and design it to protect the whole cascade against the PMF. This additional advantage is provided by the two highest alternatives studied (FSL= 1255 masl and FSL= 1290 masl). Since these benefits are inherent in the system costs for these designs, for a proper comparison, it was necessary to include the costs of providing similar flood protection benefits in the economic analysis for the No Rogun case and any of the Rogun design options which do not confer this benefit.

To quantify this, the Consultant considered the avoided costs which would have to be incurred for an alternative method, namely constructing additional spillways at the Nurek HPP. The cost of these spillways was estimated at USD 318 million, although estimates to protect the full cascade could be as much as USD 945 million.

## **CHAPTER 3.3: APPENDIX 6 – NOTE ON FREEBOARDS DUE TO WAVES**

### **1 INTRODUCTION**

Freeboard is a safety measure to take into account the difference between theoretical maximum water level of still water and the one that is increased by the tidal effects of waves and wind.

### **2 DEFINITIONS AND HYPOTHESIS**

#### **2.1 Fetch**

Fetch length is the horizontal distance of open water surface over which the wind blows. In the past, the use of the greatest straight line distance over open water in computations of waves had resulted in the calculation of wave heights that were too high, because the amount of adjoining open water with shorter but significant fetches influences the waves.

#### **2.2 Wind Velocity**

The two types of wind considered in the design criteria are specified: strong wind has a velocity of 18 m/s and extreme wind has a velocity of 32 m/s.

#### **2.3 Wave Height**

With a crest and a slope adequately protected against erosion (concrete sidewalk and asphalt road for instance), the wave height of the highest 10 per cent of waves should be used to compute run-up and freeboard i.e.  $1.27 H_s$ .

### 3 CALCULATION

#### 3.1 Wave Height

The significant wave height  $H_s$  is defined as being the average height of the highest one-third of waves.

The calculated design wave height ( $1.27.H_s$ ) is as follows:

Dam alternatives	$H_{dn}$ (strong wind)	$H_{du}$ (extreme wind)
FSL = 1290 m asl	1.15 m	2.36 m
FSL = 1255 m asl	1.15 m	2.34 m
FSL = 1220 m asl	1.14 m	2.32 m

#### 3.2 Run-up Calculation

The wave run-up on the upstream face of a dam may increase or decrease the necessary freeboard according to the following parameters studied herein:

- Upstream slope of the dam,
- Roughness and porosity,
- Angular spread of waves compared to the normal dam axis.

The calculated run-ups are presented in the next table.

	Run-up for strong wind	Run-up for extreme wind
FSL = 1290 m asl	0.99 m	1.88 m
FSL = 1255 m asl	0.98 m	1.86 m
FSL = 1220 m asl	0.98 m	1.85 m

**Table 52: Calculated Run-up**

### 3.3 Wind tide calculation

Wind tide is the piling up of water at the leeward end of an enclosed body of water, as a result of the horizontal stress on the water exerted by the wind. The calculated wind tides are presented in the next table.

	<b>Tide for strong wind</b>	<b>Tide for extreme wind</b>
<b>FSL = 1290 m asl</b>	0.002 m	0.005 m
<b>FSL = 1255 m asl</b>	0.003 m	0.004 m
<b>FSL = 1220 m asl</b>	0.003 m	0.005 m

**Table 53: Calculated wind tide Results**

The freeboards against waves are therefore the following:

	<b>Strong wing (18 m/s)</b>	<b>Extreme wind (32 m/s)</b>
<b>FSL=1290 m asl</b>	<b>0.99</b>	<b>1.88</b>
<b>FSL=1255 m asl</b>	<b>0.99</b>	<b>1.87</b>
<b>FSL=1220 m asl</b>	<b>0.98</b>	<b>1.85</b>



## CHAPTER 3.4: DRAWINGS

The following layouts are presented in report Drawings (Volume 3, Chapter 4).

Drawing N°	Rev.	TITLE		
<b>Geology</b>				
20	001	A	Geotechnical investigation	Location of the initial boreholes General Plan view
<b>Access</b>				
30	001	B	General Plan View	
30	002	B	General Plan View	
30	003	B	General Layout	
30	004	B	General Plan View	
30	005	B	Roads Profiles	General plan view
30	006	A	Roads Profiles	Access road from Douchanbe & Obigarm
30	007	B	General Plan View	Existing road
30	008	B	General plan view	Batching Plants and Aggregate Plants Layout
<b>Ionakhsh fault treatment</b>				
40	001	A	Ionakhsh Fault Treatment	Plan View Sections - Details
40	002	A	Ionakhsh Fault Treatment	Salt rise & Salt Leaching Monitoring - Principles
<b>Alternative 1 - FSL=1290 m a.s.l</b>				
40	101	A	Dam Alternative FSL=1290 m.a.s.l	Dam Plan View
40	102	A	Dam Alternative FSL=1290 m.a.s.l	Section A-A Crest Details
40	103	A	Dam Alternative FSL=1290 m.a.s.l	Stage 1 at 1110 m.a.s.l Plan view - Sections
40	104	A	Dam Alternative FSL=1290 m.a.s.l	Core Excavation Details Plan view
40	105	A	Dam Alternative FSL=1290 m.a.s.l	Core Excavation Details Elevation Upstream & Downstream
40	106	A	Dam Alternative FSL=1290 m.a.s.l	Three Dimensional Model View Plan view
40	107	A	Dam Alternative FSL=1290 m.a.s.l	Three Dimensional Model View Upstream view
40	108	A	Dam Alternative FSL=1290 m.a.s.l	Three Dimensional Model View Downstream view
40	111	B	Dam Alternative FSL 1290 m a.s.l.	Diversion Tunnels General Plan
40	113	B	Dam Alternative FSL 1290 m a.s.l.	High Level Tunnel Spillways General Plan
40	114	A	Dam Alternative FSL 1290 m a.s.l.	Mid Level Outlets General Plan
40	115	A	Dam Alternative FSL 1290 m a.s.l.	Mid Level Outlet 1 Inlet Culvert
40	117	B	Dam Alternative FSL 1290 m a.s.l.	Surface Spillway - First Stage General Plan
40	118	B	Dam Alternative FSL 1290 m	Surface Spillway - Final Stage General Plan

Drawing N°	Rev.	TITLE			
		a.s.l.			
40	119	B	Dam Alternative FSL 1290 m a.s.l.	-	General Layout - First Stage
40	120	B	Dam Alternative FSL 1290 m a.s.l.	-	General Layout - Final Stage
40	121	B	Dam FSL 1290 - 1255 - 1220	DT3 Tunnel	Profile, Intake, Gates Chamber and Sections
40	122	B	Dam FSL 1290 - 1255 - 1220	DT3 Tunnel	Gates Chamber and Outlet - Profile, Plan and Sections
40	123	A	Dam FSL 1290 - 1255 - 1220	DT3 Tunnel	Fault Crossing Structure - Pressure Stretch
40	124	A	Dam FSL 1290 - 1255 - 1220	DT3 Tunnel	Fault Crossing Structure - Free Flow Stretch
40	134	A	Dam FSL 1290 - 1255 - 1220	MLO1 Tunnel	Profile, Intake, Gates Chamber and Sections
40	135	A	Dam FSL 1290 - 1255 - 1220	MLO1 Tunnel	Profile, Gates Chamber and Sections
40	136	A	Dam FSL 1290 - 1255 - 1220	MLO1 Tunnel	Outlet - Plan and Profile
40	141	B	Dam FSL 1290	MLO2 Tunnel	Profile, Intake, Gates Chamber and Sections
40	142	B	Dam FSL 1290	MLO2 Tunnel	Gates Chamber and Outlet - Profile, Plan and Sections
40	143	B	Dam FSL 1290	MLO2 Tunnel	Vortex Chambers and Shafts - Plan and Sections
40	144	A	Dam FSL 1290	MLO2 Tunnel	Fault Crossing Structure
40	151	B	Dam FSL 1290	HLST1 Tunnel	Profile, Intake, Gates Chamber and Section
40	152	B	Dam FSL 1290	HLST1 Tunnel	Gates Chamber and Outlet - Profile, Plan and Sections
40	153	B	Dam FSL 1290	HLST1 Tunnel	Outlet - Profile and Sections
40	154	B	Dam FSL 1290	HLST2 Tunnel	Profile, Intake, Gates Chamber and Section
40	155	B	Dam FSL 1290	HLST2 Tunnel	Gates Chamber and Outlet - Profile, Plan and Sections
40	156	B	Dam FSL 1290	HLST2 Tunnel	Outlet - Profile and Sections
40	171	B	Dam Alternative FSL=1290 m a.s.l.	Surface Spillway	Final Stage - Plan View
40	172	A	Dam Alternative FSL=1290 m a.s.l.	Surface Spillway	Final Stage - Longitudinal Profile Along Tunnel 5 & 6 Axis and Sections
40	173	B	Dam Alternative FSL=1290 m a.s.l.	Surface Spillway	First Stage - Plan View
40	174	B	Dam Alternative FSL=1290 m a.s.l.	Surface Spillway	First Stage - Longitudinal Profiles Along Tunnel 2, 3 & 4
40	175	B	Dam Alternative FSL=1290 m a.s.l.	Surface Spillway	First Stage - Longitudinal Profile Along Tunnel 1 Axis and Sections
40	181	A	Dam FSL 1290	Multi Level Intakes	General Plan
40	182	A	Dam FSL 1290	Multi Level Intakes	Plan View and Sections
40	183	A	Dam FSL 1290	Multi Level Intakes	Typical Profile
<b>Alternative 2- FSL=1255 m a.s.l</b>					
40	201	A	Dam Alternative FSL=1255 m a.s.l	Dam plan view	
40	202	A	Dam Alternative FSL=1255 m a.s.l	Section A-A	Crest details
40	203	A	Dam Alternative FSL=1255 m a.s.l	Stage 1 at 1090 m a.s.l	Plan view - Sections
40	204	A	Dam Alternative FSL=1255 m a.s.l	Core excavation details	Plan view

Drawing N°		Rev.	TITLE		
40	205	A	Dam Alternative FSL=1255 m a.s.l	Core excavation details	Elevation upstream & downstream
40	211	A	Dam Crest Elevation 1265 m	Diversion Tunnels	General Plan
40	212	A	Dam Crest Elevation 1265 m	Mid Level Outlet	General Plan
40	213	A	Dam Crest Elevation 1265 m	High Level Tunnel Spillways	General Plan
40	216	A	Dam Crest Elevation 1265 m	Flushing Tunnel	General Plan
40	217	A	Dam Crest Elevation 1265 m	Surface Spillway - First Stage	General Plan
40	218	A	Dam Crest Elevation 1265 m	Surface Spillway - Final Stage	General Plan
40	219	A	Dam Crest Elevation 1265 m	-	General Layout - First Stage
40	220	A	Dam Crest Elevation 1265 m	-	General Layout - Final Stage
40	251	A	Dam El. 1265	HLST1 Tunnel	Profile, Intake, Gates Chamber and Section
40	252	A	Dam El. 1265	HLST1 Tunnel	Gates Chamber and Outlet - Profile, Plan and Sections
40	253	A	Dam El. 1265	HLST1 Tunnel	Outlet - Profile and Sections
40	254	A	Dam El. 1265	HLST2 Tunnel	Profile, Intake, Gates Chamber and Section
40	255	A	Dam El. 1265	HLST2 Tunnel	Gates Chamber and Outlet - Profile, Plan and Sections
40	256	A	Dam El. 1265	HLST2 Tunnel	Outlet - Profile and Sections
40	257	A	Dam El. 1265	HLST3 Tunnel	Profile, Intake, Gates Chamber and Section
40	258	A	Dam El. 1265	HLST3 Tunnel	Gates Chamber and Outlet - Profile, Plan and Sections
40	259	A	Dam El. 1265	HLST3 Tunnel	Outlet - Profile and Sections
40	261	A	Dam El. 1265	Flushing Tunnel	Profile, Intake, Gates Chamber and Sections
40	262	A	Dam El. 1265	Flushing Tunnel	Gates Chamber - Profile, Plan and Sections
40	263	A	Dam El. 1265	Flushing Tunnel	Outlet - Plan, Profile and Section
40	271	A	Dam Alternative FSL 1255 m a.s.l.	Surface Spillway	Final Stage - Plan View
40	272	A	Dam Alternative FSL 1255 m a.s.l.	Surface Spillway	Final Stage - Longitudinal Profile Along Tunnel 5 & 6 Axis and Sections
40	273	A	Dam Alternative FSL 1255 m a.s.l.	Surface Spillway	First Stage - Plan View
40	274	A	Dam Alternative FSL 1255 m a.s.l.	Surface Spillway	First Stage - Longitudinal Profiles Along Tunnel 2, 3 & 4
40	275	A	Dam Alternative FSL 1255 m a.s.l.	Surface Spillway	First Stage - Longitudinal Profile Along Tunnel 1 Axis and Sections
40	281	A	Dam FSL 1255	Multi Level Intakes	General Plan
40	282	A	Dam FSL 1255	Multi Level Intakes	Plan View and Sections
40	283	A	Dam FSL 1255	Multi Level Intakes	Typical Profile
<b>Alternative 3 - FSL=1220 m a.s.l</b>					
40	301	A	Dam Alternative FSL=1220 m.a.s.l	Dam plan view	
40	302	A	Dam Alternative FSL=1220 m.a.s.l	Section A-A	Crest details
40	303	A	Dam Alternative FSL=1220 m.a.s.l	Stage 1 at 1075 m.a.s.l	Plan view - Sections
40	304	A	Dam Alternative FSL=1220 m.a.s.l	Core excavation details	Plan view
40	305	A	Dam Alternative FSL=1220	Core excavation details	Elevation upstream & downstream

Drawing N°		Rev.	TITLE		
			m.a.s.l		
40	306	A	Dam Alternative FSL=1220 m.a.s.l	Three Dimensional Model View	Plan view
40	307	A	Dam Alternative FSL=1220 m.a.s.l	Three Dimensional Model View	Upstream view
40	308	A	Dam Alternative FSL=1220 m.a.s.l	Three Dimensional Model View	Downstream view
40	311	B	Dam Alternative FSL 1220 m a.s.l.	Diversion Tunnels	General Plan
40	313	B	Dam Alternative FSL 1220 m a.s.l.	High Level Tunnel Spillway	General Plan
40	314	A	Dam Alternative FSL 1220 m a.s.l.	Mid Level Outlet	General Plan
40	317	A	Dam Alternative FSL 1220 m a.s.l.	Surface Spillway - First Stage	General Plan
40	318	B	Dam Alternative FSL 1220 m a.s.l.	Surface Spillway - Final Stage	General Plan
40	319	B	Dam Alternative FSL 1220 m a.s.l.	-	General Layout - First Stage
40	320	A	Dam Alternative FSL 1220 m a.s.l.	-	General Layout - Final Stage
40	351	B	Dam FSL 1220	HLST1 Tunnel	Profile, Intake, Gates Chamber and Section
40	352	B	Dam FSL 1220	HLST1 Tunnel	Gates Chamber and Outlet - Profile, Plan and Sections
40	353	B	Dam FSL 1220	HLST1 Tunnel	Outlet - Profile and Sections
40	371	B	Dam Alternative FSL=1220 m a.s.l.	Surface Spillway	Final Stage - Plan View
40	372	B	Dam Alternative FSL=1220 m a.s.l.	Surface Spillway	Final Stage - Longitudinal Profile Along Tunnel 1 Axis and Sections
40	373	B	Dam Alternative FSL=1220 m a.s.l.	Surface Spillway	Final Stage - Longitudinal Profiles Along Tunnel 3 & 2
40	374	B	Dam Alternative FSL=1220 m a.s.l.	Surface Spillway	Final Stage - Longitudinal Profiles Along Tunnel 4, 5 & 6
40	375	A	Dam Alternative FSL=1220 m a.s.l.	Surface Spillway	First Stage - Plan View
40	376	A	Dam Alternative FSL=1220 m a.s.l.	Surface Spillway	First Stage - Longitudinal Profile Along Tunnel 1 Axis and Sections
40	377	A	Dam Alternative FSL=1220 m a.s.l.	Surface Spillway	First Stage - Longitudinal Profiles Along Tunnel 3 & 2
40	378	A	Dam Alternative FSL=1220 m a.s.l.	Surface Spillway	First Stage - Longitudinal Profiles Along Tunnel 4
40	381	A	Dam FSL 1220	Multi Level Intakes	General Plan
40	382	A	Dam FSL 1220	Multi Level Intakes	Plan View and Sections
40	383	A	Dam FSL 1220	Multi Level Intakes	Typical Profile
<b>Dam monitoring</b>					
40	401	A	Dam monitoring	Principles	Dam plan view
40	402	A	Dam monitoring	Principles	Section

## CHAPTER 3.5: RESERVOIR OPERATION STUDIES

### 1 INTRODUCTION

The proposed Rogun Hydropower Project is part of the Vakhsh Cascade which is already equipped with several operating hydropower plants (including reservoir and run of the river facilities). Future developments of the cascade are also under study and projects will be added to the existing facilities.

The Vakhsh Cascade simulation aims at optimizing the Rogun reservoir management in order to allow for optimum energy generation from the whole cascade (including future developments) in accordance with the downstream water requirements. For that purpose, all scenarios envisaged in this analysis are all in perfect adequacy with international regulation within Amudarya Basin.

Indeed, as the Vakhsh River is one of the main contributors of the Amudarya River, the optimization of the Cascade Operation should respect the regional water share agreements and practices. Afghanistan, Tajikistan, Turkmenistan, Uzbekistan, and the Aral Sea share the water from the Amudarya basin and water allocation to these countries is ruled by the Interstate Commission for Water Coordination (ICWC) as agreed in the Nukus declaration and Protocol 566.

This report presents the agreed method and assumptions, as well as the simulation results of the various scenarios and alternatives. It includes simulations covering the normal operation of the cascade (including the impact of sedimentation on this operation) and the Rogun reservoir filling period.

This study aims at assessing the future possible production of Rogun and the Vakhsh cascade taking into account the regional constraints in terms of water sharing. The outputs of this study are used in the economic and financial analysis of the proposed Rogun project alternatives as well as in the Environmental and Social Impact Assessment (ESIA) of the proposed options.

## 2 DATA AND ASSUMPTIONS

### 2.1 Vakhsh Cascade model

The Vakhsh cascade includes nine hydropower plants presently existing, under construction or under design. Seven are on the Vakhsh River: Rogun, Shurob, Nurek, Baïpaza, Sangtuda 1, Sangtuda 2, Goluvnaya. And two are on the Main Vakhsh Canal: Centralnaya and Perepednaya. This canal intake is downstream of Goluvnaya and returns to the Vakhsh river bed before its confluence with the Pyandj river.

The reservoir capacity of the various reservoirs is reported in the next table.

	Rogun 1290	Rogun 1255	Rogun 1220	Shurob	Nurek	Baïpaza	Sangtuda 1	Sangtuda 2	Goluvnaya
	Under design	Under design	Under design	Under design	In operation	In operation	In operation	In operation	In operation
<b>Live storage (hm<sup>3</sup>)</b>	10 300	6 454	3 927	5	4 200	87	18	5	4
<b>Regulation</b>	Inter-annual	Inter-annual	Inter-annual	daily	Inter-annual	weekly	daily	daily	daily

**Table 54 : Storage and regulation capacity of Vakhsh HPP's**

The next figure illustrates the Vakhsh cascade scheme as considered in the simulation. Each black triangle represents a reservoir and its hydropower plant. The green arrows represent the irrigation water flows, either withdrawn from the river or returning to the river. In the downstream part of the Vakhsh, there is a channel bringing water through two small hydropower plants. This part has not been simulated in this study as it produces only a small amount of energy compared to the other upstream plants.

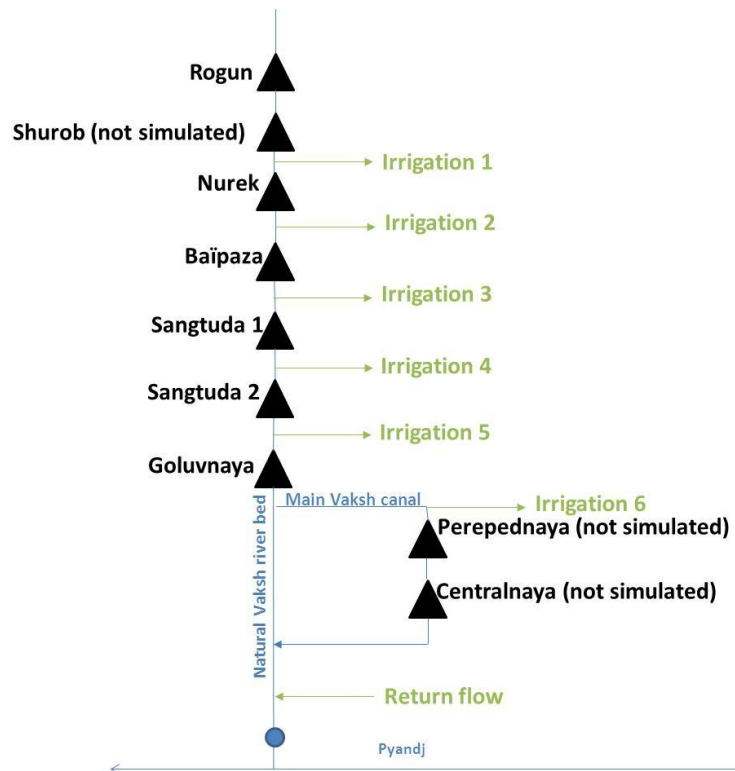

Figure 38 : Vakhsh cascade scheme

## 2.2 Inflows

Inflows have been calculated by HPI and presented in the report n°1861-II-2 – Hydrometeorological conditions. It consists in monthly discharges from April 1932 to March 2008 at Rogun site, between Rogun and Nurek, between Nurek and Baipaza, and between Baipaza and Sangtuda 1.

The consistency of these inflows calculated by HPI has been checked with other data available and was considered valid by the TEAS Consultant as input data for the simulation. The simulation is run over 76 complete hydrological years, i.e. 912 months.

## 2.3 Water withdrawals from Vakhsh River in Tajikistan

Values of water withdrawals have been thoroughly discussed with Barki Tojik and the Ministry of Water resources of Tajikistan. Several sets of water withdrawals were provided, historical and projections reproduced here below. GoT underlines that these values are in full accordance with the established limits based on agreements in force.

The following Table 55 presents the available historical chronicles (2005-2011) on average withdrawals and return flows. Table 56 gives projected values of withdrawals and return flow, estimated by GoT and using the entire amount of the water share of Tajikistan remaining below the limits set by the existing agreements and practices (in particular the Nukus Declaration and Protocol 566). These values are the one used in the simulation, respectively in the scenario b and a as defined, and considered constant during the whole simulation period.

The return flow takes into account the discharge that is going back to the Vakhsh River via the main Vakhsh canal.

The net difference in terms of volume between the two tables is 1 211 hm<sup>3</sup> per year.

Month	1	2	3	4	5	6	7	8	9	10	11	12	Yearly Volume (hm <sup>3</sup> )
Rogun-Nurek	0.97	0.97	1.47	2.03	4.02	6.96	8.89	7.07	3.96	2.10	1.00	1.00	107
Nurek-Baipaza	2.41	1.93	2.44	10.14	33.22	39.77	46.39	45.46	29.72	10.50	6.03	3.01	611
Baipaza-Sangtuda 1													0
Sangtuda 1 - Sangtuda 2	0.10	0.19	0.29	0.51	0.80	0.99	1.48	1.21	0.99	0.53	0.30	0.20	20
Sangtuda 2 – Golovnaya	0.19	0.67	2.93	5.58	7.55	8.45	8.89	7.58	5.94	3.15	2.51	0.71	143
Golovnaya-Confluence	91.18	89.42	90.10	163.22	221.20	232.12	239.26	236.49	196.32	157.57	118.34	97.89	5093
Return flow	79.38	75.54	74.44	95.59	124.16	127.09	129.85	131.50	109.72	91.02	83.11	80.08	3163

**Table 55: Average of actual water withdrawals and return flow during 2005-2011 (m<sup>3</sup>/s)**

Month	1	2	3	4	5	6	7	8	9	10	11	12	Yearly Volume (hm <sup>3</sup> )
Rogun-Nurek	5	5	10	25	40	60	75	55	30	20	10	5	899
Nurek-Baipaza	3	8	15	20	35	45	50	45	35	20	10	5	768
Baipaza-Sangtuda 1	0.2	0.2	0.5	0.8	1	1.5	2	1.5	1	0.8	0.4	0.2	27
Sangtuda 1 - Sangtuda 2	0.04	0.05	0.05	0.32	0.36	0.39	0.4	0.37	0.32	0.09	0.05	0.03	7
Sangtuda 2 – Golovnaya	0.55	0.72	3.12	5.45	9.5	11.25	12.01	9.66	8.4	5.45	2.77	0.7	184
Golovnaya-Confluence	110	115	120	170	220	230	240	230	180	150	150	120	5358
Return flow	81.95	72.73	75.66	109.1	129.41	129.37	134.52	132.83	110.35	89.49	79.86	77.36	3219

**Table 56 : Projected water withdrawals and return flow (m<sup>3</sup>/s)**



## 2.4 Reservoirs characteristics

Each plant's characteristics have been introduced in the model for the Vakhsh Cascade including Full Supply Level, Minimum Operating Level, Reservoir capacity curves, and evaporation losses in reservoirs for Rogun and Nurek.

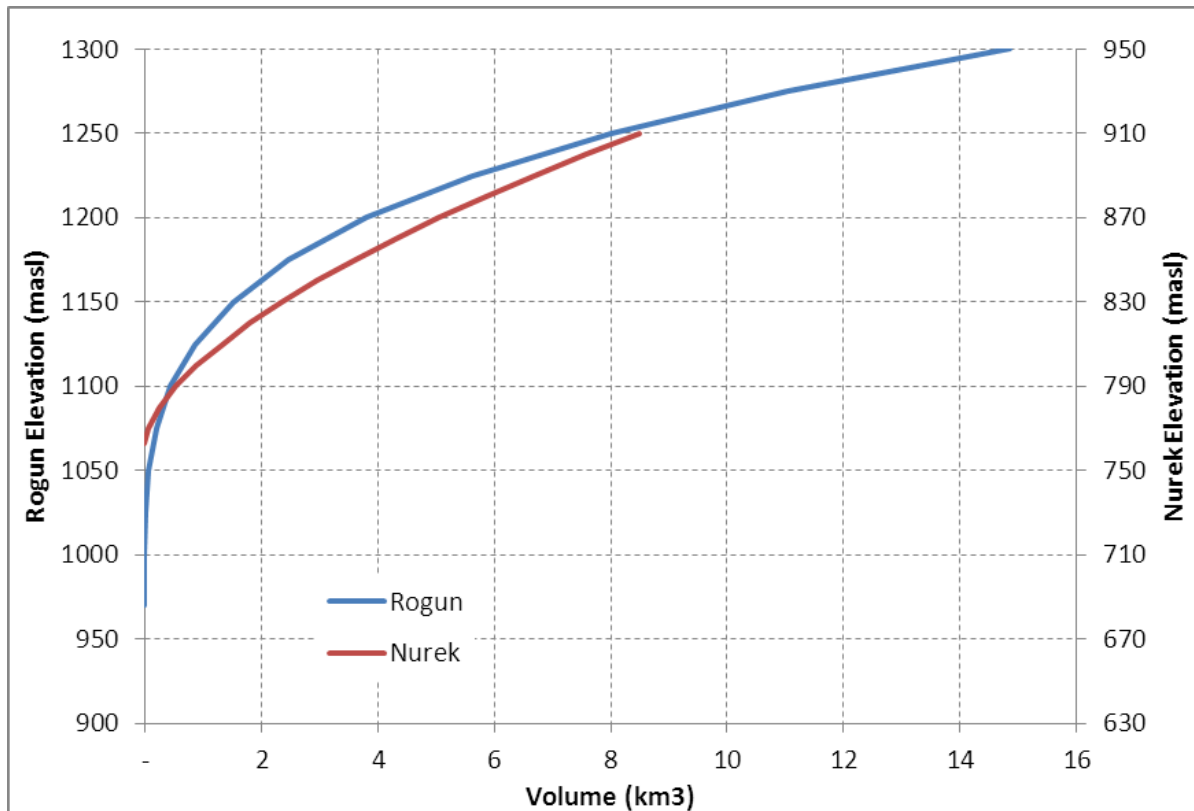

Figure 39 : Rogun and Nurek reservoir capacity vs elevation

## 2.5 Sedimentation

The effects of sedimentation have been estimated based on the USBR method, including the effects on the cascade for the no Rogun case.

The next figures present the reservoir curves for different time step for the three dam alternatives and for Nurek in the no Rogun case.

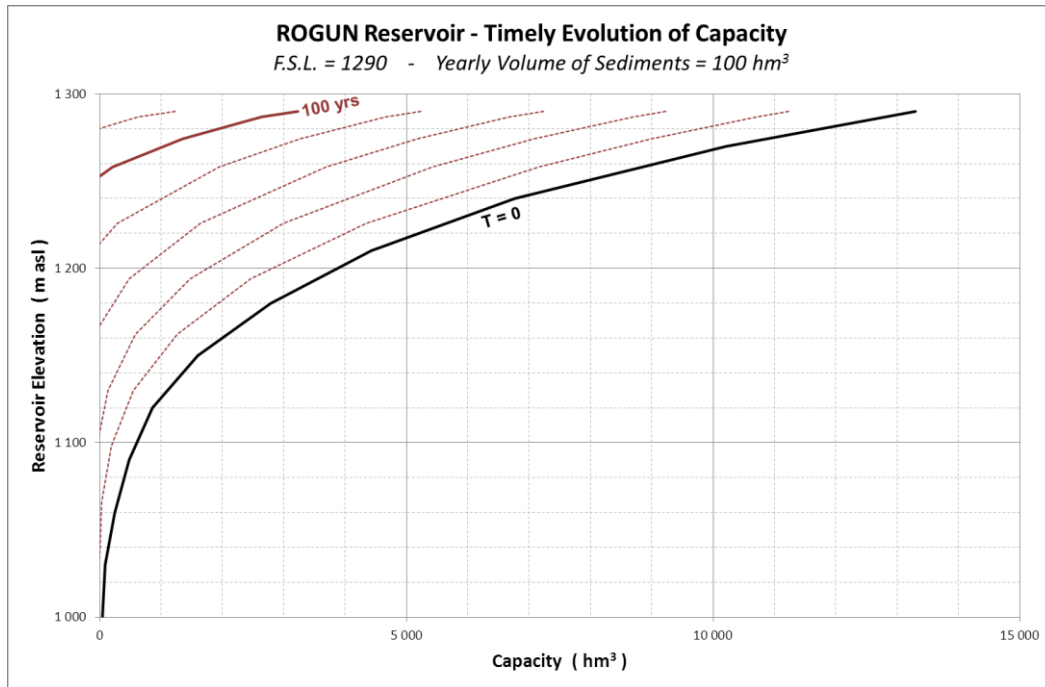

Figure 40 : Rogun reservoir storage capacity FSL =1290 masl- Impact of sedimentation

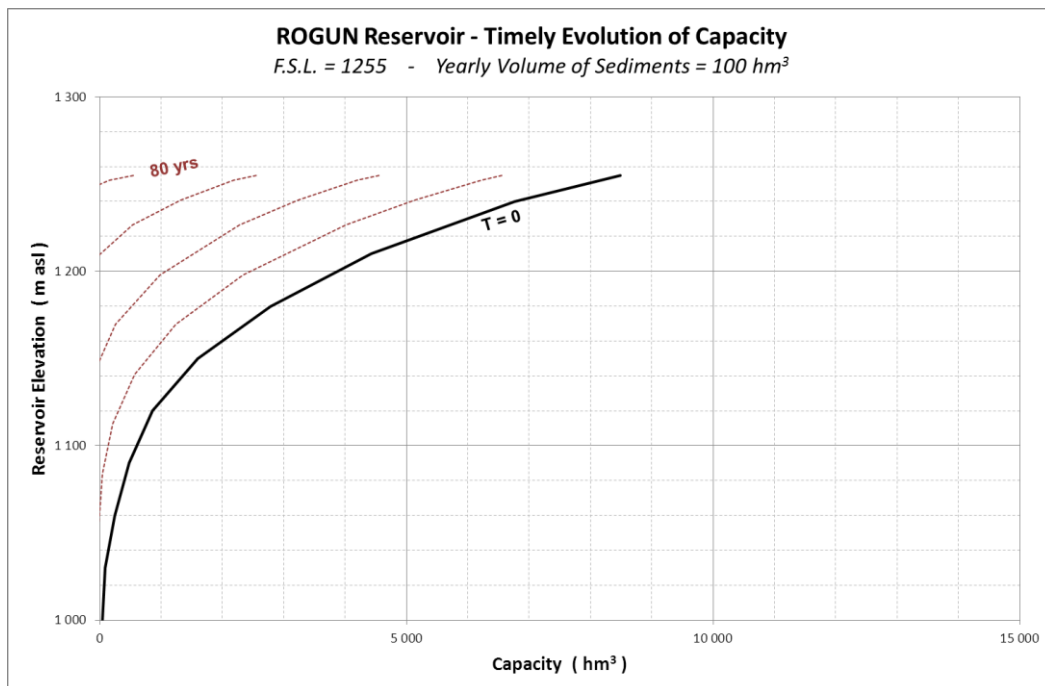

Figure 41 : Rogun reservoir storage capacity FSL =1255 masl- Impact of sedimentation

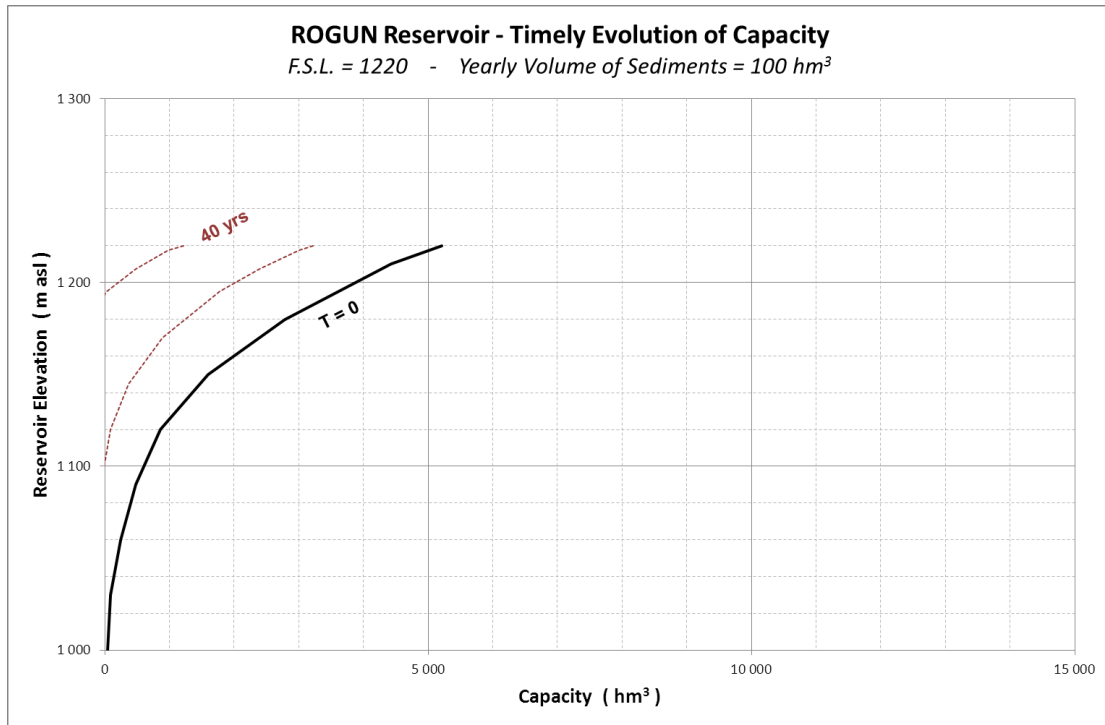

Figure 42 : Rogun reservoir storage capacity FSL =1220 masl- Impact of sedimentation

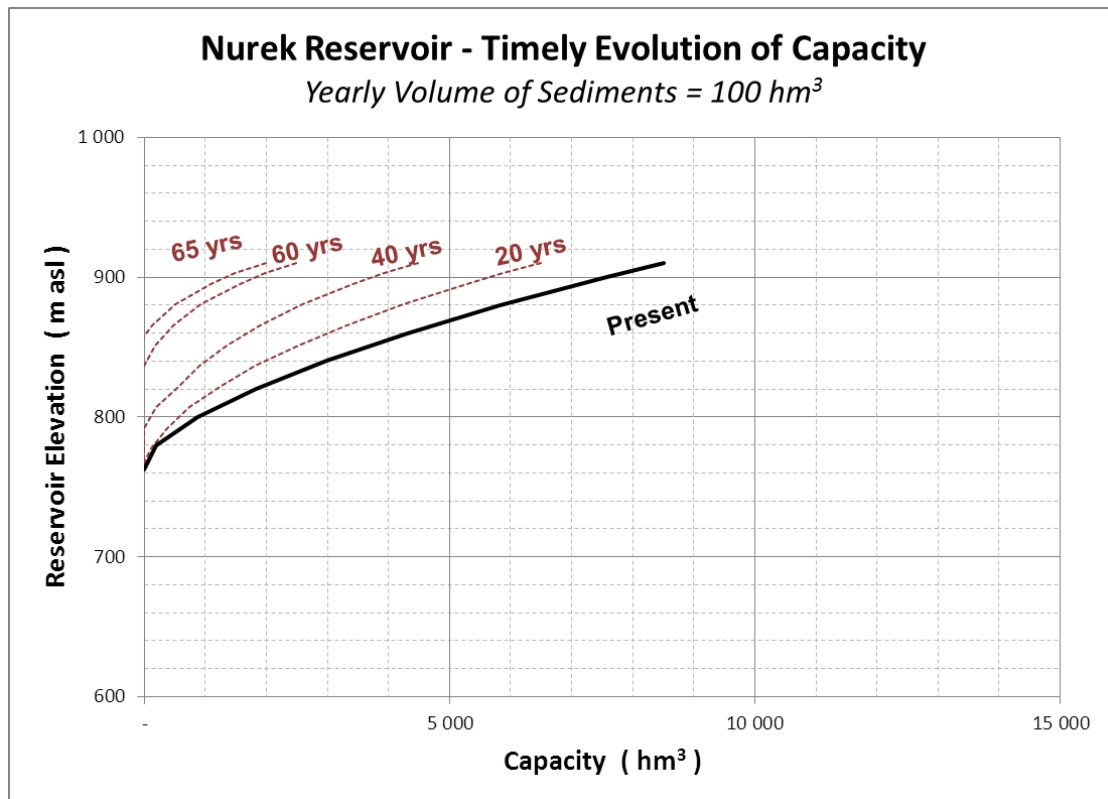

Figure 43 : Nurek reservoir storage capacity.- Impact of sedimentation without Rogun

## 2.6 Hydropower plants characteristics

To calculate the energy production of each hydropower plants, several parameters have been introduced: the tailwater level curve, the turbines efficiency and system head losses, and the installed capacity of each plant as planned.

By analyzing the generation records of the different plants, it was possible to assess the head losses in all plants, and to derive the maximum discharge capacity of each existing hydro power plant.

This is reported in the next table.

	Nurek	Baïpaza	Sangtuda 1	Sangtuda 2	Goluvnaya
<b>Installed capacity (MW)</b>	3000	600	670	220	240
<b>Estimated maximum discharge (m<sup>3</sup>/s)</b>	1500	1190	1190	1110	1090

**Table 57 : Vakhsh cascade installed capacity and maximum discharge**

## 2.7 Rogun installed capacity

At this phase of the studies, three installed capacities have been defined for each FSL alternative:

	FSL = 1220 masl	FSL = 1255 masl	FSL = 1290 masl
<b>High installed capacity</b>	2 800 MW	3 200 MW	3 600 MW
<b>Medium installed capacity</b>	2 400 MW	2 800 MW	3 200 MW
<b>Low installed capacity</b>	2 000 MW	2 400 MW	2800 MW

**Table 58 : Installed capacities selected**

The number and size of the units have not been taken into account in this study, the objective being to assess the maximum energy that can be produced regardless of the units configuration.

## 2.8 Rogun Early impounding

### 2.8.1 Schedule

The reservoir filling schedule was derived from the detailed analysis of the dam rise schedule as presented in Chapter 4.2 for each proposed dam height alternative. It was assumed that the maximum reservoir level is always 10 m lower than the level of the watertight component of the dam.

The next figure presents the dam rise schedule for the three alternatives.

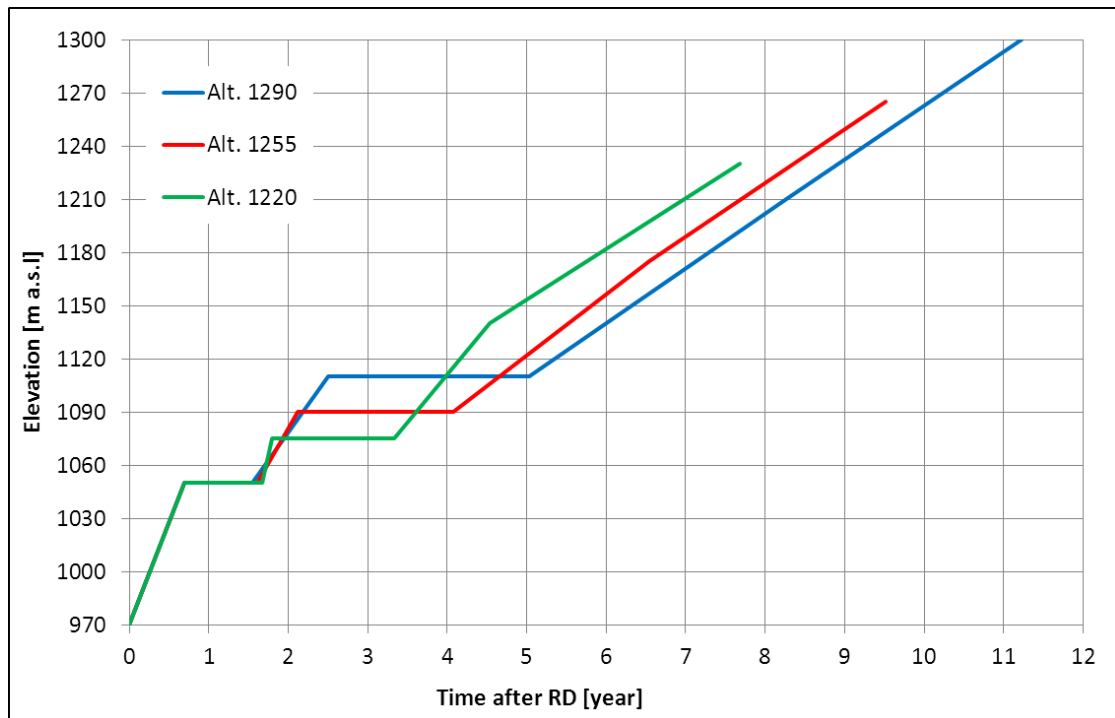

Figure 44 : Dam rise schedule - FSL=1290, 1255 and 1220 masl

### 2.8.2 Temporary units characteristics

The Rogun filling period is simulated for the three alternatives with the highest installed capacity. The temporary units commissioning sequence has been derived from the construction schedule of each proposed alternatives. This allowed determining the amount of energy generated while the project is still under construction and has been duly accounted for in the economic and financial analysis of the proposed alternatives.

The key dates for the various units commissioning are given in the following table:

	1290 masl	1255 masl	1220 masl
TEAS Validation	-	-	-
Diversion	28	28	28
Commissioning U 6 Temp.	73	73	82 (final)
Commissioning U 5 Temp.	75	75	84 (final)
End of Erection U4	85	85	85
End of Erection U3	98	98	98
End of Erection U2	112	112	112
End of Erection U1	112	112	112
Minimum Reservoir level reach	112	94	80
Temp U5 and U6 shut down	117	114	
Commissioning U 4	115	101	101
Commissioning U 3	117	114	114
Commissioning U 2	119	116	116
Commissioning U 1	121	118	118
Commissioning U 6	123	120	
Commissioning U 5	127	122	

**Table 59 : Key dates for early generation**

### 3 METHODOLOGY

#### 3.1 Basic Operation Principle of the Cascade

Given the data available, the Consultant proposed to calibrate the model with the objective that the seasonal flow pattern downstream of Nurek will remain unchanged and will mimic for the future years the outflow recorded at Nurek outlet for the period January 1991 to July 2011.

For the operational phase of the Rogun project, it is the Government's intent to limit the transfer of water from the vegetative season inflows at Rogun to the non-vegetative season releases downstream of Nurek to 4.2 BCM, which is the quantity currently transferred by the operation of the Nurek reservoir utilizing its present live storage capacity. The TEAS simulations are based upon this operating regime, which will not change the downstream flow pattern.

This methodology is adapted to the objectives of the study and the model should be accurate enough to:

- assess the additional future energy production resulting from Rogun implementation;
- check that this additional future energy production can be achieved without changing the operation principle other than the change due to the full use of Tajik water share;

The model is not meant to predict what will be the future water releases but is meant to calculate the maximum energy than can be produced by the whole cascade without changing the present operation principle for the Vakhsh cascade other than the change due to the full use of Tajik water share.

The calibration period is defined as the longest common period between the inflows series (1932-2008) and the Nurek past operation data (1991-2010), ie 1991-2008. The simulation period is defined as the longest inflows series available: 1932-2008.

Simulated structures	Period 1991-2008	Period 1932-2008
Nurek alone	Model calibration	-
Nurek and the downstream cascade	-	Energy production improvement
Rogun, Nurek and the downstream cascade	-	- Rogun and Nurek coupled operation optimization - Computation of all scenarios

**Table 60 : Calibration Period and Model Simulation Period**

### 3.2 Nurek operation understanding

The Nurek past operation records of outflows, reservoir level and energy produced have been provided from 1991 to 2011.

The only regular pattern observed in the past Nurek operation is the reservoir level variation that almost always varies from the full supply level (910 masl) in September to the minimum operating level (857 masl) in April. This means that as of today the entire live storage of Nurek is transferred from summer months to winter months, in order to meet the energy demand of Tajikistan in winter. This aspect was used for model calibration.

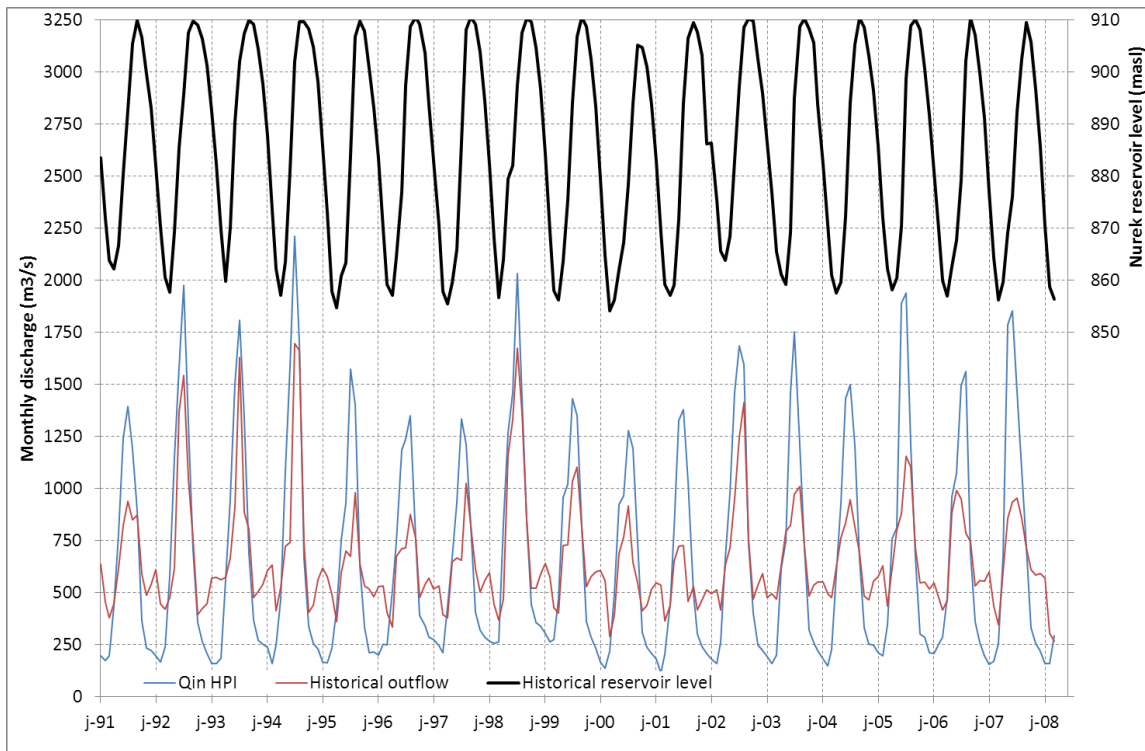

**Figure 45 : Historical Nurek outflow and reservoir level (1991-2008)**

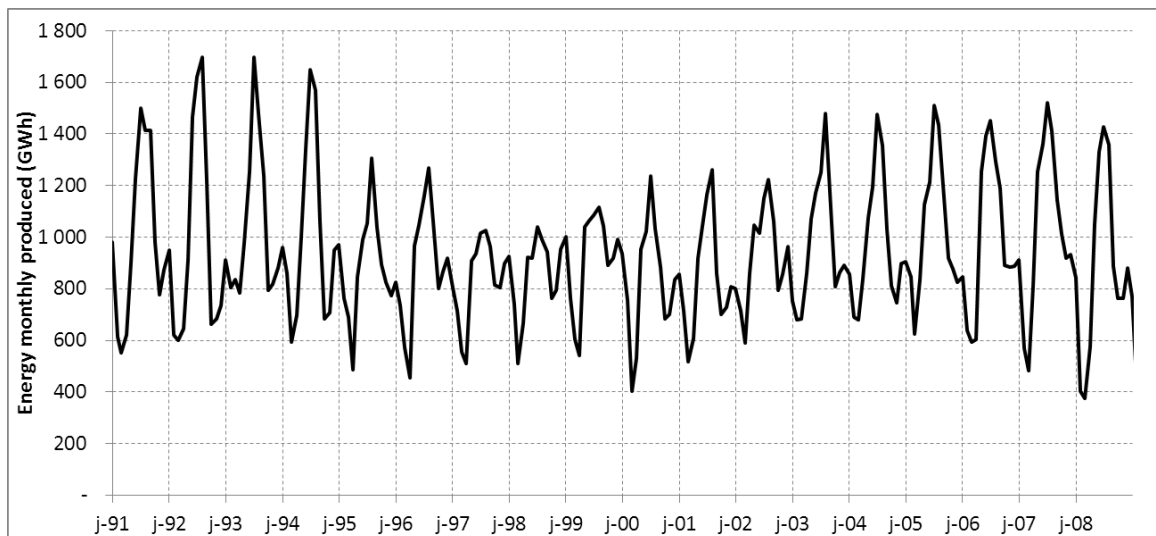

**Figure 46: Historical Nurek energy production (1991-2008)**

### 3.3 Model calibration

It has been chosen to impose a reservoir level operation rule curve at Nurek to simulate the past operation of the Vakhsh cascade in order to check the calibration of the model and evaluate the associated uncertainties. This calibration is made on the downstream discharge to reproduce the present flow pattern and not on the recorded energy outputs.



Here under the flow duration curve of simulated and historical outflows is plotted.

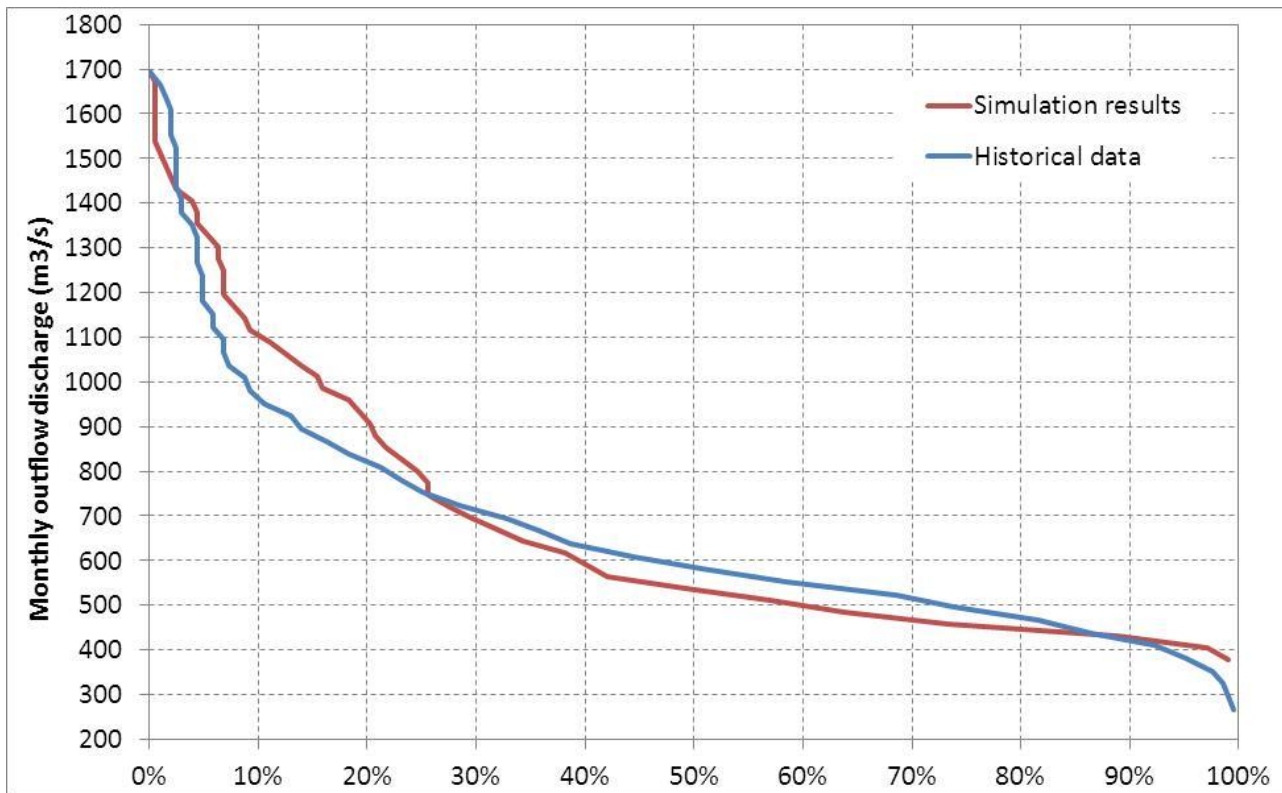

**Figure 47 : Nurek Outflows duration curve (historical and simulated)**

As presented, the model gives a reasonable approximation of the Vakhsh cascade behavior, considering full availability of equipment; and the various assumptions made lead to an acceptable systemic error with respect to the objectives of the study.

### 3.4 Nurek operation improvement

The operation rule found in the previous paragraph allows reproducing the past behavior of Nurek. No additional optimization of any kind has been done at this point.

With a trial and error procedure, the reservoir rule curve has been modified in order to have more water available in February and March and produce more energy in these months. It means that the reservoir level should be lowered more slowly at the beginning of winter so that enough water remains until the end of winter. In that case, less energy is produced in October but more in February-March when the demand is still high. This procedure aimed at increasing the 95% probability of exceedance of winter energy ( $E_{w-95\%}$ ).

This improvement of Nurek operation has not changed the summer outflows but only the distribution of winter outflows. The total volume stored remains unchanged and corresponds to Nurek active storage capacity. Therefore, the regulation of the river and the operation principle of the Vakhsh River have not been changed.

### **3.5 Rogun and Nurek coupled operation**

The principle established previously imposes a certain level of regulation that is limited by Nurek active storage capacity and that cannot be increased. Once Rogun comes online, this regulation volume can be shared between Rogun and Nurek reservoirs. This coupled operation optimization has been made in the simulation, in order to optimize primarily winter energy.

### **3.6 Rogun and Nurek coupled operation during Rogun filling**

The optimum Rogun level for which the regulation starts in Rogun has been studied. It has been found that the optimum in term of winter energy is:

- to operate Rogun as a run-off-the river hydropower plant (regulation ratio is 0) as long as the reservoir level is lower than 1140 masl;
- Then, to start regulate in Rogun (regulation ratio is 0.2) and to gradually increase the regulation in Rogun as the reservoir level rises;
- And to perform the complete regulation in Rogun (regulation ratio = 1) when the reservoir level reaches 1210 masl.

## 4 SCENARIOS STUDIED

### 4.1 Simulation scenario cases for normal operation

As mentioned earlier, for the need of numerical simulations, the following boundary conditions have always been observed:

- It is the Government's intent to limit the transfer of water from the vegetative season inflows at Rogun to the non-vegetative season releases downstream of Nurek to 4.2 BCM, which is the quantity currently transferred by the operation of the Nurek reservoir utilizing its present full storage capacity; that is to say the Vakhsh river operation principle remains unchanged.
- The monthly irrigation withdrawals and return flows between Rogun and the end of Vakhsh cascade (confluence with the Pyandj river) have been evaluated by GoT, but in any case remain in compliance with the Nukus Declaration (Protocol 566) and within the limits set by the ICWC for the Vakhsh river in application of Nukus declaration and Protocol 566.

Different cases have been simulated for each FSL:

#### ***a) Current status extrapolated***

- The Vakhsh river operation principle remains unchanged;
- The withdrawals and return flow are derived from the factual data of 2005-2011 on the Vakhsh river. This data shall be consistent with the decade data (limits and facts) that were published by ICWC.

#### ***b) Base line – Future use of Tajikistan water share***

- The Vakhsh river operation principle remains unchanged;
- The withdrawals and return flow monthly values are average projected values estimated by GoT using full water share of Vakhsh and remaining below the limits set up by the Nukus declaration and Protocol 566.

It is to be noted that the impact of **sedimentation** into Rogun reservoir has been studied on case (b) all along the project life span.

For comparison purposes, the **current cascade scenario** (i.e. without Rogun) has also been simulated as a baseline scenario.

## 4.2 Simulation scenario for Rogun reservoir filling

In addition to the Normal Operation cases, the Consultant has also run the reservoir filling period assuming the following:

- The Vakhsh river operation principle remains unchanged;
- The withdrawals and return flow are derived from the factual data of 2005-2011 on Vakhsh River not exceeding the share of Tajikistan for the Vakhsh river as set by the ICWC in application of the Nukus declaration and Protocol 566 limits.
- The Government's intent is to fill the Rogun reservoir using part of the share allocated to Tajikistan under current agreements and practices. Tajikistan does not use its full share for irrigation from the Amudarya (particularly from the Vakhsh River), and between 2005 and 2011 the average unused Tajik share from the Vakhsh River was 1.2 BCM. Assuming that this situation would continue to prevail until the end of the filling period, this unused share would be sufficient to fill the reservoir without reducing current irrigation in Tajikistan. The TEAS simulations are thus based upon the assumption that 1.2 BCM of unutilized Tajik share of Vakhsh flows would be available annually for initial filling of the reservoir.
- Construction period for the three FSL alternatives are the ones determined by the Consultant.
- Limitations due to triggered seismicity or other potential limiting factors are taken into account in defining the rate of filling of the reservoir during construction.

## 4.3 Recapitulative chart

The next table shows all the scenarios and alternatives that have been studied. As a total, 20 simulations have been run.

	Installed capacity	(a)	(b)	Filling	(b) + sedimentation
<b>Without Rogun</b>		yes	yes		
<b>FSL = 1290 masl</b>	<b>3600 MW</b>	yes	yes	yes	yes
	<b>3200 MW</b>		yes		
	<b>2800 MW</b>		yes		
<b>FSL = 1255 masl</b>	<b>3200 MW</b>	yes	yes	yes	yes
	<b>2800 MW</b>		yes		
	<b>2400 MW</b>		yes		
<b>FSL = 1220 masl</b>	<b>2800 MW</b>	yes	yes	yes	yes
	<b>2400 MW</b>		yes		
	<b>2000 MW</b>		yes		

Table 61 : Scenario and alternatives simulated

## 5 SIMULATION RESULTS FOR NORMAL OPERATION

### 5.1 Synthesis and comparison of results

#### 5.1.1 Energy production

The next tables present the firm, the secondary and the average energy produced by the entire cascade for each scenario studied.

Firm energy (GWh)		(a)	(b)
<b>Without Rogun</b>		13 040	12 528
<b>FSL = 1290 masl</b>	<b>3600 MW</b>	22 762	22 360
	<b>3200 MW</b>	-	22 360
	<b>2800 MW</b>	-	22 360
<b>FSL = 1255 masl</b>	<b>3200 MW</b>	21 730	21 240
	<b>2800 MW</b>	-	21 240
	<b>2400 MW</b>	-	21 240
<b>FSL = 1220 masl</b>	<b>2800 MW</b>	20 140	19 560
	<b>2400 MW</b>	-	19 560
	<b>2000 MW</b>	-	19 560

Table 62 : Vakhsh cascade firm energy of all simulated scenario

Secondary energy (GWh)		(a)	(b)
<b>Without Rogun</b>		6 870	6 556
<b>FSL = 1290 masl</b>	<b>3600 MW</b>	12 552	12 141
	<b>3200 MW</b>	-	12 031
	<b>2800 MW</b>	-	11 809
<b>FSL = 1255 masl</b>	<b>3200 MW</b>	11 622	11 240
	<b>2800 MW</b>	-	11 144
	<b>2400 MW</b>	-	10 921
<b>FSL = 1220 masl</b>	<b>2800 MW</b>	10 886	10 596
	<b>2400 MW</b>	-	10 512
	<b>2000 MW</b>	-	10 274

**Table 63 : Vakhsh cascade secondary energy of all simulated scenario**

Average yearly energy (GWh)		(a)	(b)
<b>Without Rogun</b>		19 910	19 084
<b>FSL = 1290 masl</b>	<b>3600 MW</b>	35 314	34 441
	<b>3200 MW</b>	-	34 331
	<b>2800 MW</b>	-	34 109
<b>FSL = 1255 masl</b>	<b>3200 MW</b>	33 352	32 480
	<b>2800 MW</b>	-	32 384
	<b>2400 MW</b>	-	32 161
<b>FSL = 1220 masl</b>	<b>2800 MW</b>	31 026	30 155
	<b>2400 MW</b>	-	30 072
	<b>2000 MW</b>	-	29 834

**Table 64 : Vakhsh cascade average energy of all simulated scenario**

The energy produced by the whole cascade is much more important with Rogun: 74%, 64% and 54% more for respectively the dam alternatives 1290, 1255 and 1220 masl.

It should also be reminded that here the “Without Rogun” scenario have been improved compared to the historical production: the guaranteed energy ( $E_{95\%-W}$ ) has been improved by 21% while the average energy remains the same.

The differences between scenario (a) and scenario (b) are limited: the energy produced in scenario (b) is 1.4-4% lower than scenario (a) depending on the alternatives. The highest difference (4%) is for the average energy produced without Rogun.

The next graphs presents the comparison of the energy produced within a year in scenario (b), by the Vakhsh cascade with the three Rogun dam alternatives with their maximum installed capacity and by the Vakhsh cascade without Rogun.

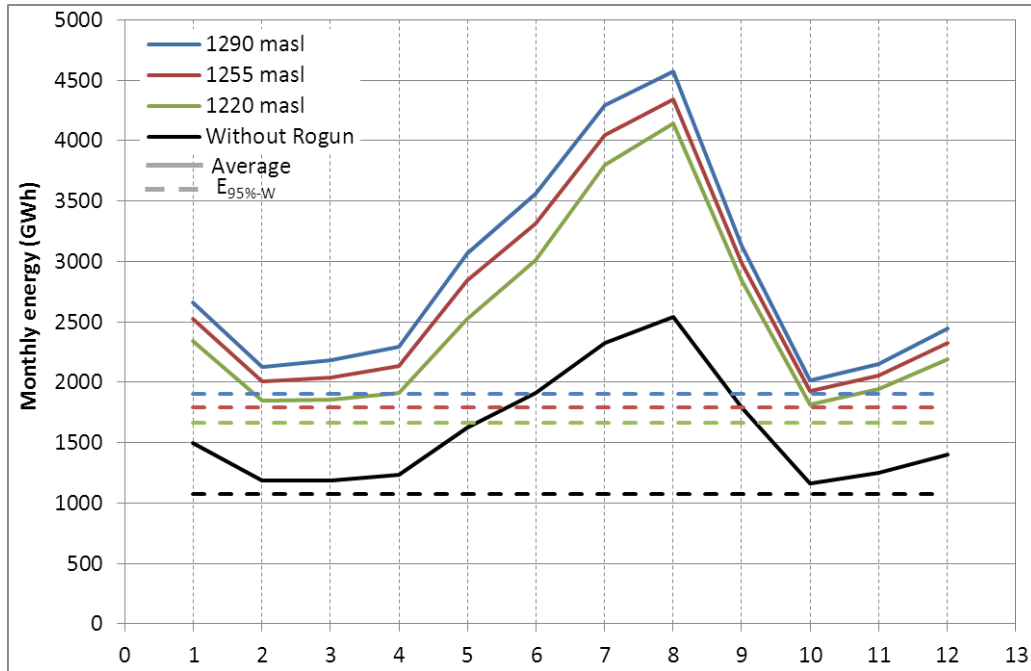

**Figure 48 : Vakhsh cascade production - Comparison of the alternatives, Scenario (b)**

The next graphs presents the comparison of the energy produced within a year in scenario (a), by the Vakhsh cascade with the three Rogun dam alternatives with their maximum installed capacity and by the Vakhsh cascade without Rogun.

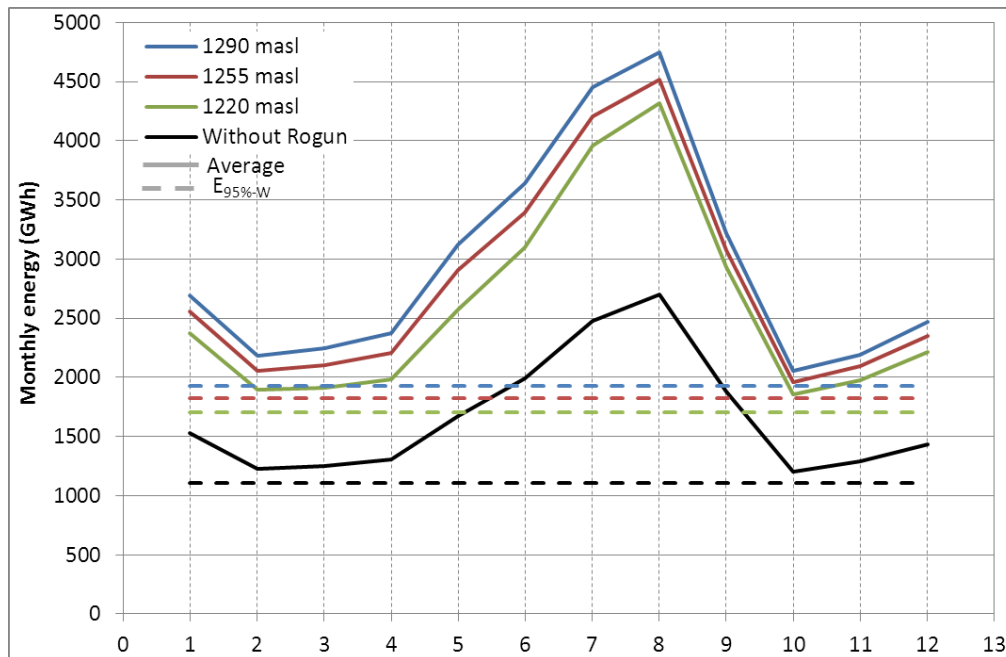

Figure 49: Vakhsh cascade production - Comparison of the alternatives, Scenario (a)

## 6 SIMULATION RESULTS – FILLING PERIOD

### 6.1 Hydrological situation

While the Normal Operation has been computed on the whole simulated period (from 1932 to 2008) in the case of filling, the simulation is run only on the 10-18 years of reservoir filling.

It has been chosen to run the reservoir filling simulation by using the typical average year 1937.

### 6.2 FSL = 1290 masl

The simulation results are presented hereafter:



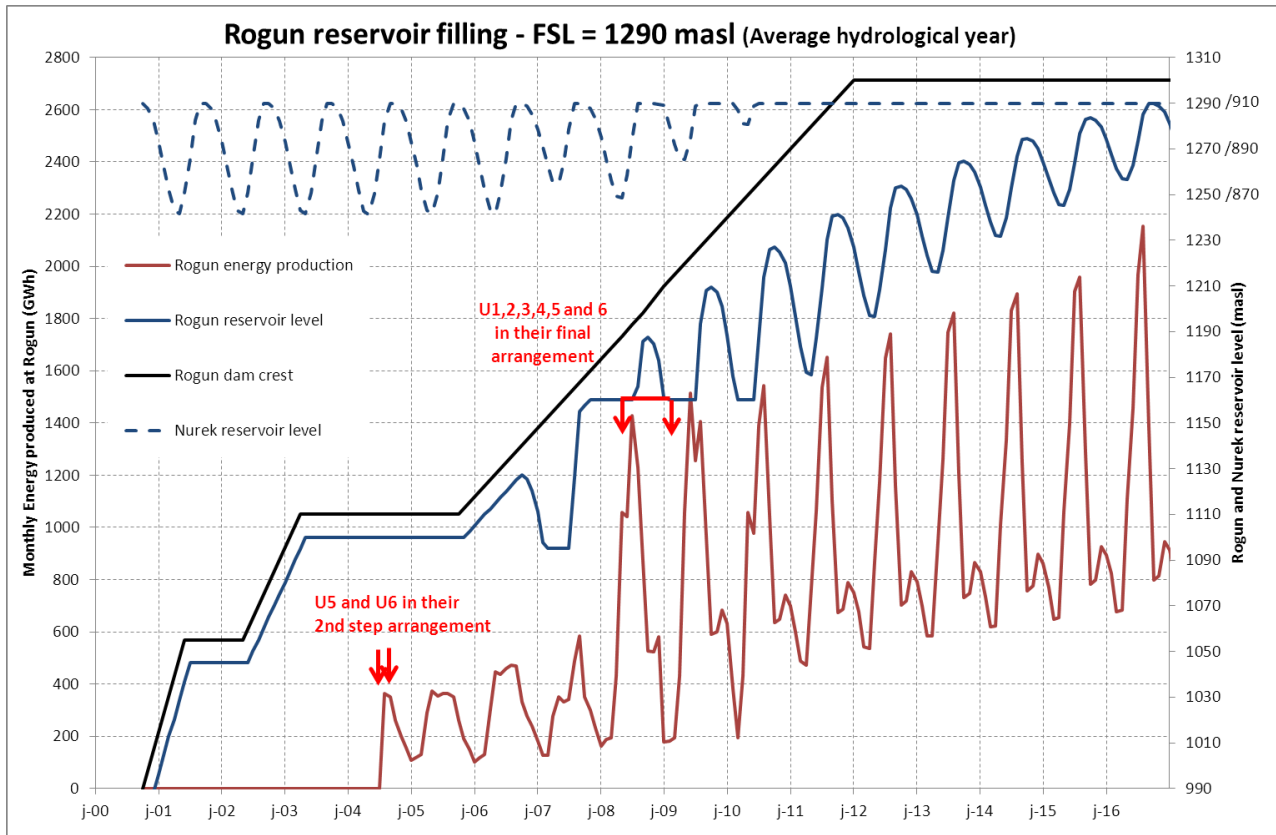

**Figure 50 : Rogun reservoir filling - Simulation results FSL=1290 masl**

Rogun regulation capacity starts to be used at the end of year 6. From then, Vakhsh river regulation is more and more performed in Rogun and less and less in Nurek.

It can be seen that the reservoir reaches its full supply level 16 years after the river diversion, while the dam is completed after 11.2 years.

The 1<sup>st</sup> step arrangement of the units 5 and 6 is not used: when works required to put them in operation are finished, the reservoir level is already outside of their operating range.

As for the energy, as long as the Rogun regulation capacity is not used, the winter production is limited. Nevertheless, it produces from 100 to 150 GWh per month which represents from 9 to 14% of the rest of cascade production.

As soon as the Rogun regulation capacity is used (year 7), the winter energy produced progressively increases up to 600 to 800 GWh per month.

The summer production is limited in the first years (until year N+8) because of the unit capacity and numbers.

During the whole filling period (16 years), the additional energy produced by the cascade compared the “Without Rogun (a)” scenario is 111 TWh. It matches 7.7 years of Rogun normal operation. The energy produced only by the two temporary units is 11.8 TWh and 4.1 TWh in winter only.

Year	Rogun average yearly energy (GWh)	Rogun average winter energy (GWh)
N+4	1 332	617
N+5	3 058	962
N+6	3 787	1 200
N+7	3 694	1 318
N+8	8 241	2 180
N+9	9 064	2 432
N+10	9 675	3 234
N+11	10 534	3 936
N+12	11 350	4 222
N+13	11 987	4 421
N+14	12 553	4 615
N+15	13 052	4 787
N+16	13 702	4 953
<b>TOTAL</b>	<b>112 029</b>	<b>38 876</b>

**Table 65 : Rogun filling - Energy production - FSL=1290 masl**

The next graph presents the discharge at the downstream end of the cascade and compares the Rogun filling with normal operation in scenario (b).

It is to be pointed out that during the first 7 years of the filling period; the discharge at the downstream end of the cascade is higher in the filling of Rogun scenario than in scenario (b). After the 7<sup>th</sup> year, the two are perfectly superimposed. It means that the volume allowed for reservoir filling is not fully used for the first 7 years of reservoir filling.

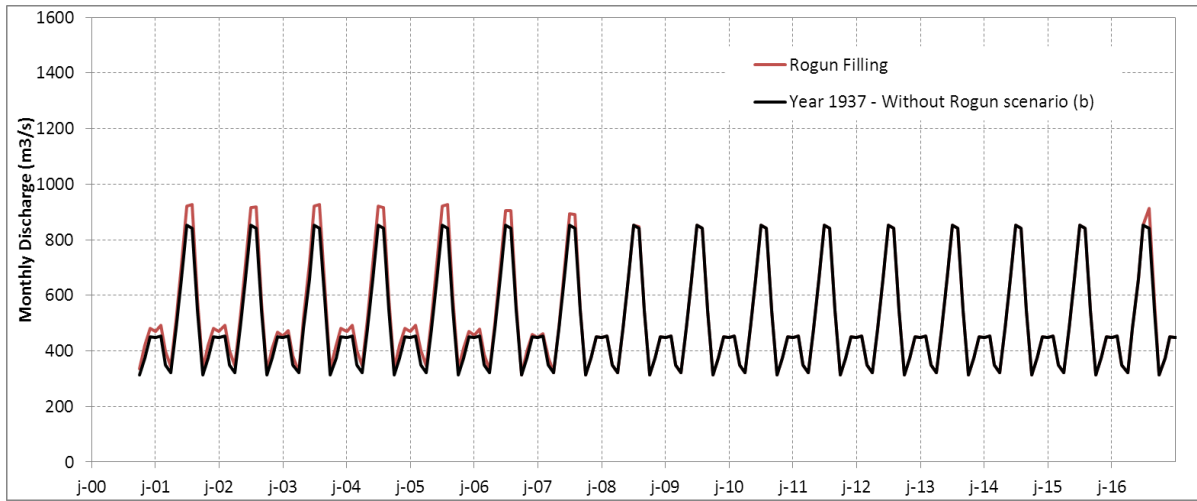

Figure 51 : Discharge at the downstream end of the Vakhsh - Filling FSL=1290 masl

### 6.3 FSL = 1255 masl

The simulation results are presented hereafter:

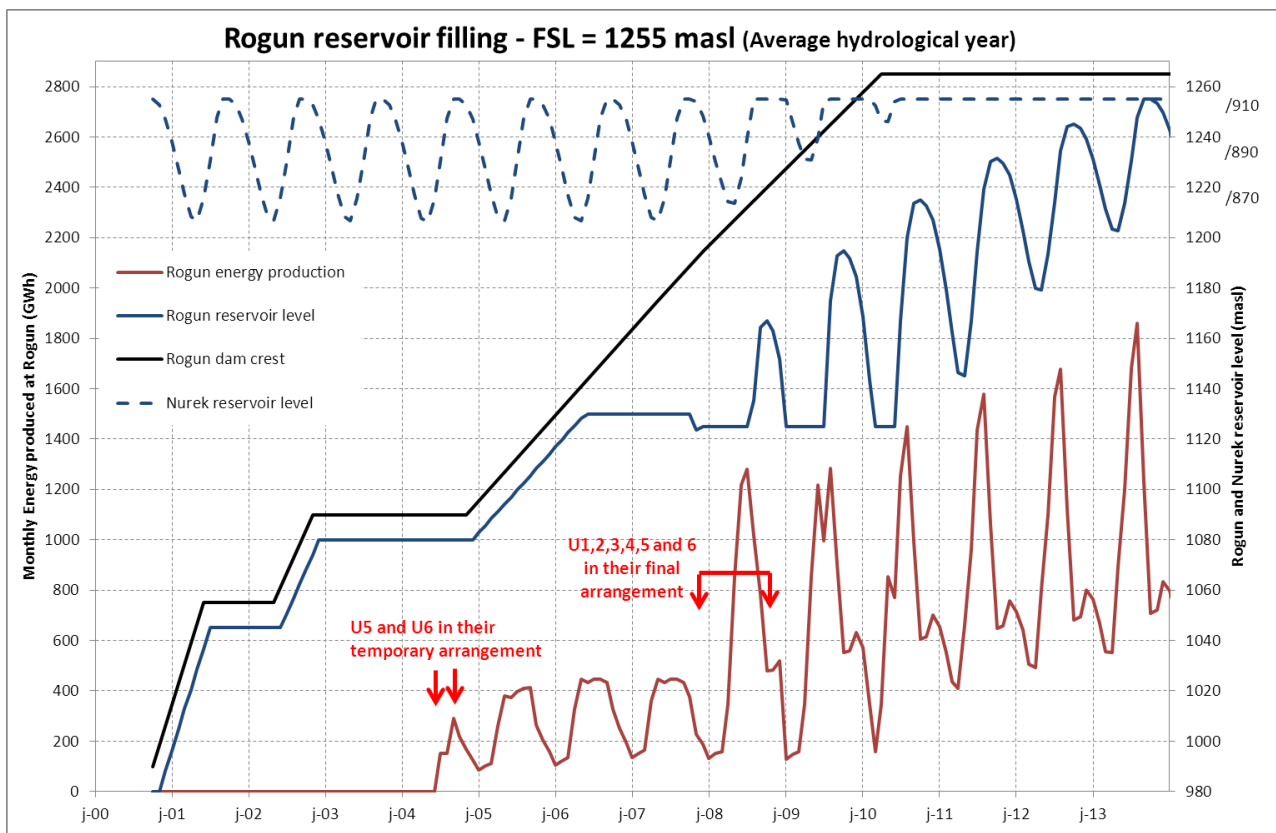

Figure 52 : Rogun reservoir filling - Simulation results FSL=1255 masl

Rogun regulation capacity starts to be used in year 8. From then, Vakhsh river regulation is more and more performed in Rogun and less and less in Nurek.

It can be seen that the reservoir reaches its full supply level 13 years after the river diversion, while the dam is completed after 9.5 years.

As for the energy, as long as the Rogun regulation capacity is not used, the winter production is limited. Nevertheless, it produces from 100 to 150 GWh per month which represents from 9 to 14% of the rest of cascade production.

As soon as the Rogun regulation capacity is used (year 8), the winter energy produced progressively increases up to 600 - 800 GWh per month.

During the whole filling period (13 years), the additional energy produced by the cascade compared the “Without Rogun (a)” scenario is 68.6 TWh. It matches 5.5 years of Rogun normal operation. The energy produced only by the two temporary units is 11.7 TWh and 3.8 TWh in winter only.

Year	Rogun average yearly energy (GWh)	Rogun average winter energy (GWh)
N+4	1 102	509
N+5	3 157	925
N+6	3 664	1 135
N+7	3 807	1 244
N+8	7 422	1 925
N+9	7 782	2 180
N+10	8 666	2 999
N+11	9 819	3 707
N+12	10 800	4 039
N+13	11 664	4 249
<b>TOTAL</b>	<b>67 885</b>	<b>22 912</b>

**Table 66 : Rogun filling - Energy production - FSL=1255 masl**

The next graph presents the discharge at the downstream end of the cascade and compares the Rogun filling with normal operation in scenario (b).

It is to be pointed out that during the first 6 years of the filling period, the discharge at the downstream end of the cascade is higher in the filling of Rogun scenario than in scenario (b). After the 6<sup>th</sup> year, the two are superimposed. It means that the volume allowed for reservoir filling is not fully used for the first 6 years of reservoir filling.

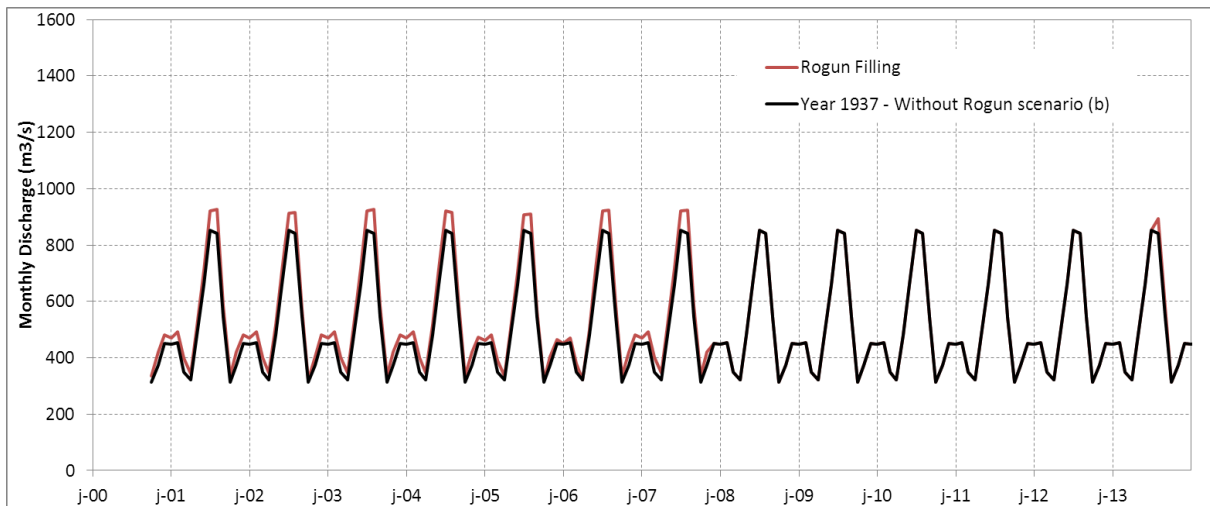
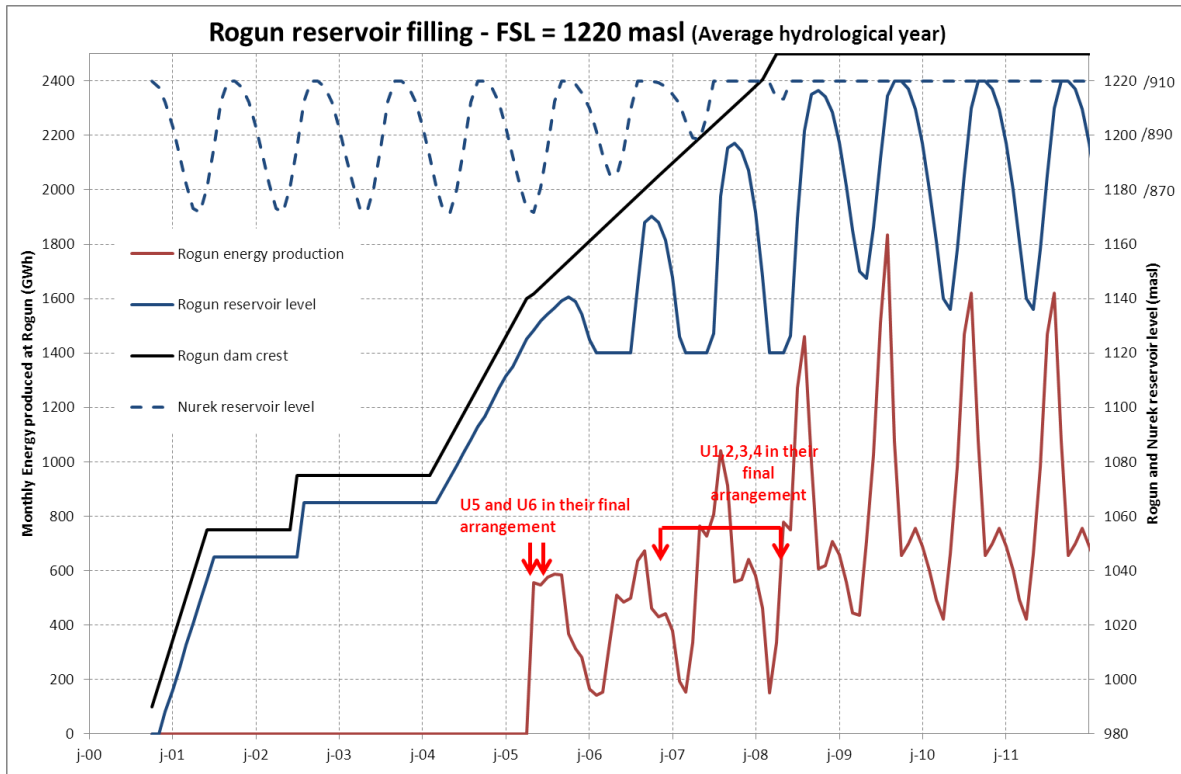

Figure 53 : Discharge at the downstream end of the Vakhsh - Filling FSL=1255 masl

#### 6.4 FSL = 1220 masl

The simulation results are hereafter:



**Figure 54 : Rogun reservoir filling - Simulation results FSL=1220 masl**

Rogun regulation capacity starts to be used at the end of year 5. From then, Vakhsh river regulation is more and more performed in Rogun and less and less in Nurek.

It can be seen that the reservoir reaches its full supply level 9 years after the river diversion, while the dam is completed after 7.7 years.

As for the energy, as long as the Rogun regulation capacity is not used, the winter production is limited. Nevertheless, it produces from 100 GWh to 150 per month which represents from 9 to 14% of the rest of cascade production.

As soon as the Rogun regulation capacity is used (year 6), the winter energy produced increases up to 600-700 GWh per month.

The temporary arrangement of the units 5 and 6 is not used: when works required to put them in operation are finished, the reservoir level is already outside of their operating range.

During the whole filling period (9 years), the additional energy produced by the cascade compared the “Without Rogun (a)” scenario is 37.2 TWh. It matches 3.7 years of Rogun normal operation.

Year	Rogun average yearly energy (GWh)	Rogun average winter energy (GWh)
N+4		
N+5	3 817	960
N+6	4 931	1 794
N+7	7 080	2 489
N+8	8 725	3 129
N+9	10 368	3 773
<b>TOTAL</b>	<b>34 921</b>	<b>12 146</b>

**Table 67 : Rogun filling - Energy production - FSL=1220 masl**

The next graph presents the discharge at the downstream end of the cascade and compares the Rogun filling with normal operation in scenario (b).

It is to be pointed out that during the first 6 years of the filling period, the discharge at the downstream end of the cascade is higher in the filling of Rogun scenario than in scenario (b). After the 6<sup>th</sup> year, the two are superimposed. It means that the volume allowed for reservoir filling is not fully used for the first 6 years of reservoir filling.

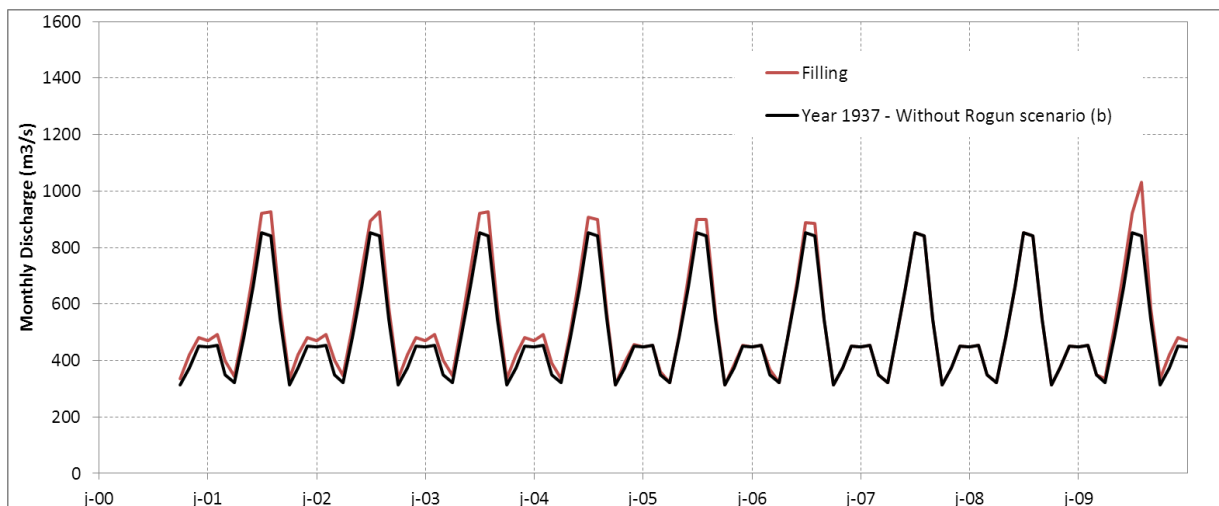

**Figure 55 : Discharge at the downstream end of the Vakhsh - Filling FSL=1220 masl**

## 6.5 Comments on triggered seismicity

The Rogun site is likely to experience triggered seismicity phenomena during the reservoir filling because of the various faults located in the reservoir.

The most intense events should occur during the first phase of filling, the first 60-80 m. It is indeed at the beginning that the greatest relative change in the field pore pressure will occur.

In general, to limit triggered seismicity the reservoir filling should be done slowly and continuously. As the Rogun reservoir filling is done only by using the Tajik water withdrawal share, it is indeed very regular until the regulation starts. At its highest rate, the reservoir filling is 9 meters per month.

The topic of triggered seismicity is also dealt with in the seismicity chapter (Vol 2 Chapt 6). There, it is noted that, during Nurek filling, no significant triggered seismicity was detected when the filling rate was lower than 15 m/month.

In addition, to prevent such phenomena, a thorough monitoring of the reservoir area should be implemented as soon as possible: firstly to determine the existing background seismicity and thereafter during reservoir filling to detect any triggered seismicity and adapt the reservoir filling rate accordingly.

## 7 CONCLUSIONS AND RECOMMENDATIONS

The main results in terms of energy production are synthesized in the next two tables. The first one presents the average yearly energy, the second one presents the firm energy and the secondary energy.

Average yearly energy produced (TWh)								
	Rogun			Nurek	Rest of Vakhsh cascade	Total Vakhsh cascade		
	1290	1255	1220			1290	1255	1220
<b>Historical</b>				11.7	8.2	19.9		
<b>Improved Nurek operation (a)</b>				11.7	8.2	19.9		
<b>Improved Nurek operation (b)</b>				11.3	7.8	19.1		
<b>With Rogun (a)</b>	14.4	12.4	10.1	12.8	8.1	35.3	33.3	31.0
<b>With Rogun(b)</b>	14.4	12.4	10.1	12.3	7.8	34.4	32.5	30.2



Firm energy produced (TWh)								
	Rogun			Nurek	Rest of Vakhsh cascade	Total Vakhsh cascade		
	1290	1255	1220			1290	1255	1220
<b>Historical</b>				6.1	4.8	10.9		
<b>Improved Nurek operation (a)</b>				7.6	5.4	13.0		
<b>Improved Nurek operation (b)</b>				7.2	5.3	12.5		
<b>With Rogun (a)</b>	9.3	7.9	5.9	8.1	5.4	22.8	21.7	20.1
<b>With Rogun(b)</b>	9.3	7.9	5.9	8.0	5.1	22.4	21.2	19.6
Secondary energy produced (TWh)								
	Rogun			Nurek	Rest of Vakhsh cascade	Total Vakhsh cascade		
	1290	1255	1220			1290	1255	1220
<b>Historical</b>				5.6	3.4	9		
<b>Improved Nurek operation (a)</b>				4.1	2.8	6.9		
<b>Improved Nurek operation (b)</b>				4.1	2.5	6.6		
<b>With Rogun (a)</b>	5.1	4.5	4.2	4.7	2.8	12.6	11.6	10.9
<b>With Rogun(b)</b>	5.1	4.5	4.2	4.3	2.7	12	11.3	10.6

The study has shown that the present operation of Nurek could be improved to keep a constant energy production all along winter season: the firm energy production has been improved by 21%. The average energy remains constant.

It also shows that Rogun has a major impact on the electricity production of the whole Vakhsh cascade: Rogun own production is added but it also increases the Nurek production. Indeed, the river regulation is made in Rogun and Nurek remains mostly at its full supply level, increasing the head of the discharge through the turbines. The energy produced by the whole cascade is 74%, 64% and 54% more than “without Rogun” for respectively the dam alternatives 1290, 1255 and 1220 masl.

The energy production of the cascade is sensitive to the hydrology: the wet years allow producing 10% more energy than average years and in dry years it is decreased by 8%.

The dam alternative FSL 1255 masl produces a firm energy 5% lower than the dam alternative FSL 1290 masl. The dam alternative FSL 1220 masl produces a firm energy 12.5% lower than the dam alternative FSL 1290 masl. The energy difference is only due to the head difference in Rogun. It is therefore limited as an important part of the energy produced by the whole cascade is produced in Nurek and is the same (or nearly) for the three alternatives.

The Rogun filling period have also been studied. It shows that it is possible to fill Rogun only by using the differential volume between the Tajik water share and their present water use. It will take respectively 16, 13 and 9 years for the dam alternatives FSL=1290, 1255 and 1220 masl to reach the normal operation.

It is to be noted that the river regulation will be done in Rogun as soon as possible as it has a significant impact on the winter energy; it will start 7, 8 and 5 years after river diversion for the dam alternatives FSL=1290, 1255 and 1220 masl. The total amount of energy produced during that period is equivalent to 7.7, 5.5 and 3.7 ordinary years for respectively the dam alternatives FSL=1290, 1255 and 1220 masl.

These operation results are achieved within the framework of the existing agreements and practices among the countries sharing the Amudarya basin. This means that the full regulation capacity of the cascade (Rogun and Nurek) is not used but is limited to the regulation presently performed by Nurek.

## CHAPTER 3.6: TRANSMISSION SYSTEM

### 1 INTRODUCTION

The scope of the electrical transmission network study is the analysis of the impact of the new hydro power plant of Rogun on the high voltage transmission system of Tajikistan.

The objective of the study is to evaluate the export capabilities of the system and to identify the most adequate network expansion solution. The aim of the performed analyses is to:

- Verify that the total power produced by the new power plant, in the various stages of the Project's implementation, can be reliably transferred to load centers by the Tajik Transmission System, based on the calculation of transfer capabilities of the planned HV network for the selected destinations under various operation conditions;
- Detect the grid bottlenecks and evaluate the need to reinforce the Transmission System through the identification of the most appropriate new reinforcements, by duplicating line circuits and increasing the transformers' rated power, as well as through the adoption of capacitor banks in a few cases, in order to sustain the voltage profiles. These reinforcement actions were designed according to the criteria of increasing the size of lines and transformers only when strictly necessary (loading of the above elements growing to more than 100%);
- Estimate the yearly transmission losses in the target years with different solutions, in order to allow a better economic evaluation.

These calculations were performed on the base of the Tajik transmission system's data provided by many data sources, even though the data were not always perfectly consistent and not always exhaustive.

Therefore, with the aim of properly calibrating the model, some preliminary models of the Tajik Transmission System as it stands today were issued and submitted to the Client, and the corresponding comments were taken into account during the preparation of the final version. The simulations obtained are as accurate as possible, and the results can be used with confidence for the purpose of the studies.

## 2 REFERENCE DOCUMENTS

The study is based on several documents provided by “Barki Tajik”, Fichtner (former studies) and SNC Lavalin. Many of these documents are data collection for the detailed description of the transmission system. One of the most significant documents is the latest demand forecast.

## 3 SYSTEM DESCRIPTION

The Tajik transmission system is composed of:

- 4 500kV substations (7 in 2016);
- 31 220kV substations (31 in 2016);
- 8 lines at 500 kV (17 in 2031);
- 60 lines at 220 kV (64 in 2016);
- 63 load transformers in 31 substations, for a foreseen total peak of approx. 3,816 MW (5,948 MW in 2031), according to the 75th percentile peak demand forecast determined by the TEAS Consultant;
- 14 power plants for a total of 49 generation groups, with 5,100 MW of installed power (8,700 MW in 2031).

## 4 METHODS AND SOFTWARES USED FOR THESE STUDIES

### 4.1 Used Software

The calculations are performed using the software simulator DIGSILENT PowerFactory, version 14.1. Detailed information on this tool is available with the Consultant and can be conveniently shared

Some data pre-processing and results post-processing were performed with Microsoft™ Excel™.

## 4.2 Used Methods: Load-Flow

Load-flow calculations were performed using the complete Newton-Raphson method. The tolerances are equal to 1 kVA or to the 0.1% of the power flowing in each node.

The shunt parameters of the lines (capacitance) and of the transformers (no load current, no load losses) have been fully considered, by means of  $\Pi$  (lines) or T (transformers) representation.

The generators and the "external grids" that represent neighboring countries can be represented as "PV" or "PQ" sources, or "slack" sources. Furthermore, they can be controlled by means of secondary voltage/reactive power controllers (Power Plant controllers, Area controllers) and by means of secondary frequency/active power controllers that allow automatic sharing of the reactive and active power in order to obtain proper voltage levels in pilot busbars and a proper power sharing in the entire system. These devices have been used for all (u/Q) or the most important (f/P) generators of the Tajik system, while the "external grids" have been set in PQ mode.

Following these calculations, the results below indicated were obtained:

- Bus results (voltages in kV and per unit, phase angle in degrees);
- For each branch, the active and reactive power and current on each side, the loading with respect to the maximum current capability, the losses with the detail of load and no load losses;
- For the shunt elements (generators, motors(1), loads), the produced or absorbed active and reactive power and current and the loading, with respect to the maximum current capability;

## 5 CONFIGURATIONS AND CASES

### 5.1 Horizon Years

The study starts from the year 2013, and considers the time horizons of years 2020, 2025, 2027, 2028 and 2031.

---

1 *No motors have been represented explicitly in this study.*

With reference to Rogun HPP, according to the *Comments to the final revisions of electric network study* delivered by OSHPC “BARKI TOJIK”:

- in 2020, “End of stage 1 dam” in case of dam FSL 1290 m, 2 generators are foreseen to be in operation with a power of 200 MW each one (400 MW total power);
- in 2025, “End of Main Dam Construction” for dam FSL 1220 m, all six units are foreseen to be in operation, for a total of 2,000 MW;
- in 2027, “All Units (1 to 6)” in case of dam FSL 1290 m, 6 generators are foreseen to be in operation with a total power of 2,160 MW;
- in 2028, “End of Main Dam Construction” for dam FSL 1255 m and capacity of 2,800 MW, all six units are foreseen to be in operation, for a total of 2,800 MW;
- finally, in 2031, all 6 generators will arrive at the full power of 600 MW each one, for a total of 3,600 MW, for dam FSL 1290 m.

Over this time, some reinforcement actions are expected on the 500 kV Tajik transmission system, with some new transmission links that are shown in the table here in after:

Name	Line Type	Station 1	Station 2	Vn [kV]	Length [km]	Irated [kA]	In Service since
L-S-I	Line_220 kV AC-400 bis	SUGHD	T_Shahristan	220	90	0.825	2011
L-S-I(1)	Line_220 kV AC-400 bis	T_Shahristan	AINI	220	28	0.825	2011
L-D-O-1	Line_500 3x kV AC-400	DUSHANBE	OBIGARM	500	100	2	2014
L-D-O-2	Line_500 3x kV AC-400	DUSHANBE	OBIGARM	500	100	2	2014
L-G-R	Line_220 kV AC-400	GERAN	RUMI	220	75	0.705	2014
L-K-A	Line_220 kV AC-400	ASHT	KAYROKUM	220	70	0.705	2014
L-24-KB/1	Line_220 kV AC-400	T-Shurob-1	KAYROKUM	220	52	0.69	2016
L-24-KB/2	Line_220 kV AC-300	T-Shurob-2	KANIBADAM	220	15	0.69	2016
L-KAN-S	Line_220 kV AC-400	T-Shurob-2	SHUROBSKAYA	220	15	0.705	2016
L-KAY-S	Line_220 kV AC-400	T-Shurob-1	SHUROBSKAYA	220	15	0.705	2016
L-Regar-Sangtuda1	Line_500 3x kV AC-400	REGAR	SANGTUDA-1	500	115	2	2016
L-Obi-Rogun HPP/1	Line_500 3x kV AC-400	OBIGARM	ROGUN HPP	500	8	2	2016
L-Obi-Rogun HPP/2	Line_500 3x kV AC-400	OBIGARM	ROGUN HPP	500	8	2	2016
L-Obi-Rogun HPP/3	Line_500 3x kV AC-400	OBIGARM	ROGUN HPP	500	8	2	2016
L-O-S	Line_500 3x kV AC-400	OBIGARM	SUGHD	500	285	2	2020
L-Obi-Sangtuda	Line_500 3x kV AC-400	OBIGARM	SANGTUDA-1	500	126	2	2020
L-O-Y	Line_500 3x kV AC-400	OBIGARM	YUZHAYAYA	500	216	2	2028
L-S-Y	Line_500 3x kV AC-400	SANGTUDA-1	YUZHAYAYA	500	90	2	2028

**Table 68: Scheduled New 500 KV Connections**

## 5.2 Load levels and load yearly growth

The initial load conditions are based on the 2013 forecast reported in the studies conducted the TEAS Consultant, where a peak load of 3,816 MW is foreseen for that year, given as an overall figure. The sharing of these 3,816 MW among the various loads has been obtained using the information provided for **Loads for Substations**, where a total load of 2,790 MW was expected for 2011-12. All local load values have been increased in the same measure, excluding the load of TALCO (“Regar”), that remains constant, in order to arrive to 3,816 MW.

The **Loads for Substations** document also reports a minimum value for 2011-12 that is about 41% of the peak, while the studies conducted in the frame of the TEAS allowed identifying also the yearly energy. Using these values, an estimation of the hourly loading was done, and it has been found that, assuming that the peak value is valid for 760 hours per year (about 2 h per day), with the minimum for 3,860 hours and an average value  $((\text{min}+\text{max})/2)$  for the remaining 4,140 hours,

the energy indicated in the TEAS is almost perfectly obtained. This load profile has been used for the estimation of losses.

The information provided with respect to the **Daily and annual load demands** reports daily and monthly values that allow computing the yearly energy absorbed by the loads as 2,069 MW x 8,760 h (the 2010 table has been extrapolated to 2012, assuming a growth factor of 4.5% a year).

The exact calculation of the losses requires knowing the detailed load profile along the year (hourly load value in MW for each one of the 8760 hours of year). This information is not available; available data are only the maximum (peak) load, the minimum load and the yearly load energy. An equivalent yearly load profile has therefore been estimated, as explained above: maximum load for 760 h, average load for 4,140 h and minimum load for 3,860 h, leading to the expected yearly energy. These 3 cases, each multiplied by its number of hours, are used for the estimation of the yearly losses.

For what attains the load growth rate, the values corresponding to the case are named “75<sup>th</sup>” if the Consultant’s studies have been used. The following table reports the expected yearly energy and peak power:

Table 1: IPA annual demand forecast (GWh)

	2010	2011	2012	2013	2014	2015	2016	2017	2018	2019	2020	2025	2030	2035	2040	2045	2050
Min.	16,220	16,634	17,266	17,216	17,166	16,315	16,139	15,963	15,703	15,571	15,441	16,169	17,541	19,085	20,824	22,782	24,987
25th	16,220	16,816	17,560	18,031	18,543	18,224	18,552	18,845	19,059	19,376	19,722	21,784	23,974	26,991	30,307	34,415	38,567
Median	17,220	17,816	18,570	19,020	19,492	19,162	19,536	19,943	20,240	20,664	21,096	23,842	26,717	30,575	35,283	41,217	48,052
75th	18,220	18,805	19,557	19,987	20,400	20,096	20,589	21,029	21,412	21,985	22,566	26,147	30,075	35,472	42,125	50,646	60,265
Max.	18,220	19,025	19,912	20,799	21,744	21,950	22,898	23,916	24,824	25,918	27,073	33,889	41,093	50,635	63,168	79,163	99,577

Table 1: IPA peak demand forecast (MW)

	2010	2011	2012	2013	2014	2015	2016	2017	2018	2019	2020	2025	2030	2035	2040	2045	2050
Min.	3,097	3,176	3,296	3,287	3,277	3,115	3,081	3,048	2,998	2,973	2,948	3,087	3,349	3,644	3,976	4,350	4,771
25th	3,097	3,211	3,353	3,443	3,540	3,479	3,542	3,598	3,639	3,699	3,765	4,159	4,577	5,153	5,786	6,571	7,363
Median	3,288	3,402	3,545	3,631	3,722	3,659	3,730	3,808	3,864	3,945	4,028	4,552	5,101	5,838	6,736	7,869	9,174
75th	3,479	3,590	3,734	3,816	3,895	3,837	3,931	4,015	4,088	4,198	4,308	4,992	5,742	6,772	8,043	9,670	11,506
Max.	3,479	3,632	3,802	3,971	4,152	4,191	4,372	4,566	4,740	4,948	5,169	6,470	7,846	9,667	12,060	15,114	19,012

There is no information about a possible redistribution of the load on the territory over the 18 years considered. Therefore, it has been assumed that the same growth occurs in all load stations, excluding the TALCO load, for which a constant value is expected. It has also been assumed that no new load locations are created, and no old ones are dismissed.

This growth, which varies between 1.8% and 3% a year (with a small decrease in 2015), **requires a significant reinforcement of the entire 220 kV Tajik transmission network** and of the load transformers, etc.



A detailed analysis would require knowing the true territorial redistribution of the load and other information (possible new line paths, etc.) that are not available. In order to obtain running load-flow cases for what attains the 500 kV system aimed to verify the export capability, some basic reinforcements have been done on the 220 kV system. The modifications are reported in the following sections.

### 5.3 Existing power plants

At the present time, the Tajik system includes several plants, with the main HPPs (Hydro Power Plant) and HTPs (Thermal Power Plant), totaling at nearly 5,346 MW in existing installed capacity. With the Rogun Power Plant, the installed capacity will become 8,946 MW.

The table below lists the existing and planned Tajik plants:

Power Station	Sub-Station	Pn [MW]	In Service since
Gen VARZOB-HPP1	NOVAYA	9.5	Existing
Gen VARZOB-HPP2	NOVAYA	14.4	Existing
Gen VARZOB-HPP3	NOVAYA	3.52	Existing
Gen-Centralnaya	KOLKHOZABAD	15.1	Existing
Gen-Perepadnaya	GOLOVNAYA	29.95	Existing
HPP11-SANGT1	SANGTUDA-1	670	Existing
HPP24-KAYR	KAYROKUM	126	Existing
HPP5-GOLOV	GOLOVNAYA	240	Existing
HPP7-NUREK	NUREKSKAYA	3000	Existing
HPP8-BAYPAZA	BAYPAZA	600	Existing
HPP12-SANGT2	SANGTUDA-2	220	Existing
HTP-DUSHANBE	DUSHANBE	198	Existing
HTP-DUSHANBE-2	DUSHANBE	100	2013
HPP-Rogun-1	OBIGARM	600	2019
HPP-Rogun-2	OBIGARM	600	2019
HPP-Rogun-3	OBIGARM	600	2026
HPP-Rogun-4	OBIGARM	600	2026
HPP-Rogun-5	OBIGARM	600	2027
HPP-Rogun-6	OBIGARM	600	2027
HTP-Yavan	YAVAN	120	Existing

**Table 69: Tajik Power Plants**

## 5.4 Connections to Neighboring Countries and Connection Alternatives

The possible connections to the neighboring systems can be summarized as follows:

- 220 kV AC connection between SANGTUDA-2 S/S and Afghanistan KUNDUZ S/S (approx. 180 km);
- 500 kV AC connection between SUGHD S/S and Kirgizstan DATKA S/S (approx. 477 km);
- 500 kV AC connection between REGAR S/S and Uzbekistan SURKAN S/S (approx. 162 km);
- 500 kV AC connection between REGAR S/S and Uzbekistan GUZAR S/S (approx. 255 km);
- 500 kV DC connection between SANGTUDA-1 and KABUL S/S and PESHAWAR S/S (Afghanistan and Pakistan).

The AC lines have been represented in detail; the DC lines are simply represented as a static load at the location of the AC/DC converter device. There is no need for a detailed representation since, for the purpose of this study, it is sufficient to demonstrate that the AC transmission system and the generators are able to transfer to the AC/DC converter the required active power to be exported.

## 5.5 N-1 Safety

For the longest time horizon (year 2031), the N-1 conditions on the 500 kV transmission system have been explored, first in the base case (with no Export) and then in the various Export cases. It has been found that the outage of some lines is also critical in the base case, while for the other outages and for each Export case, the required Export power reduction level has been found.

## 5.6 Losses

The losses in the 500 and 220 kV transmission system have been found for each horizon year, load level and export condition, with an equivalent total of lost energy in each year. For each year, the yearly losses are found by multiplying the losses of 1 h in each one of the 3 sample conditions: max., average and min. load, for the corresponding equivalent number of hours: 760, 4,140 and 3,860, respectively.

## 6 NETWORK REINFORCEMENTS

As described above, the growth load requires the reinforcement of the existing 220 kV Tajik transmission system.

The most adequate reinforcement choices would require to know the exact share of the load growth among the various load centers, the location of potential new load centers (that are probably not yet foreseen at present), and the activation of true network planning studies, to be updated frequently, including OPF/ORPF studies (Optimal Active/Reactive Power Flows), that are only possible when the above information is available.

The reinforcements action applied in this study are therefore an approximation of what would be really required, with the unique purpose of having proper load-flow cases running without violation; choices done with the information available at present. The mentioned violations refer to the lines and transformers loading and bus voltages. The actions are distributed along years 2013-31, with the main steps taking place in 2013, 2020, 2025, 2027 and 2031, and they can be summarized as follows:

### 2013

- Line duplications (9 cases – 279 km);
- 3 winding transformers duplication (6 cases – 810 MVA)
- Load transformers rated power increases of 33% (3 cases – ref. to 432 MVA).

### 2020

- Line duplications (3 cases – 62 km);
- 3 winding transformers duplication (1 case – 32 MVA);
- Load transformers rated power increases of 33% (8 cases – ref. to 714 MVA).

### 2025

- Line duplications (5 cases – 135 km);
- 3 winding transformers duplication (6 cases – 900 MVA);
- Load transformers rated power increases of 33% (9 cases – ref. to 1,928 MVA);
- Application of MV shunt capacitors with sizes of 50 Mvar (2 cases).

### 2027

- Line duplications (2 cases - 40 km) and triplications (3 cases – 103 km);

- 3 winding transformers duplication (1 case – 25 MVA);
- Load transformers rated power increases of 33% (6 cases – ref. to 410 MVA);
- Application of MV shunt capacitors with sizes of 30 (2 cases) or 50 Mvar (1 case).

### 2028

- Load transformers rated power increases of 33% (1 case – ref. to 501 MVA).

### 2031

- Line duplications (2 cases – 55 km);
- Load transformers rated power increases of 33% (7 cases – ref. to 1,003 MVA);
- Application of shunt MV capacitors with sizes of 30 (2 cases) or 50 Mvar (4 cases).

The next table reports the actions on the 500 kV transmission system that were already programmed (by Barki Tojik), except for the short connections lines between Rogun Power Plant and Obigarm substation.

Year	Rogun Power [MW]	Item	Identification	Vn [kV]	From Station	To Station	Reinforcement action
2014	-	Line	L-D-O-1	500	DUSHANBE	OBIGARM	Programmed (*)
2014	-	Line	L-D-O-2	500	DUSHANBE	OBIGARM	Programmed (*)
2016	-	Line	L-Regar-Sangtuda1	500	REGAR	SANGTUDA-1	Programmed (*)
(**)	-	Line	L-Obi-Rogun HPP/1	500	OBIGARM	ROGUN HPP	Necessary
(**)	-	Line	L-Obi-Rogun HPP/2	500	OBIGARM	ROGUN HPP	Necessary
(**)	-	Line	L-Obi-Rogun HPP/3	500	OBIGARM	ROGUN HPP	Necessary (***)
2020	400	Line	L-O-S	500	OBIGARM	SUGHD	Programmed (*)
2020	400	Line	L-Obi-Sangtuda	500	OBIGARM	SANGTUDA-1	Programmed (*)
2028	2800	Line	L-O-Y	500	OBIGARM	YUZHAYA	Programmed (*)
2028	2800	Line	L-S-Y	500	SANGTUDA-1	YUZHAYA	Programmed (*)

(\*) the Reinforcement Actions indicated as “Planner” were already scheduled by Barki Tojik

(\*\*) Year depends upon the alternative under consideration

(\*\*\*) 3 lines from L-Obi-Rogun HPP/1 to OBIGARM are necessary in case the scheduled capacities of Rogun HPP were the maximum ones, 3600 MW, 3200 or 2800 MW. In case of smaller capacities, the 3<sup>rd</sup> line is not strictly required

## 7 CONCLUSIONS AND RECOMMENDATIONS

The growth projections in energy demand for the horizon years considered lead to a significant increase (from a peak of about 3.8 GW in 2013 to a peak of more than 5.9 GW in 2031) with

consequent overload of some elements of the transmission and distribution network. These problems can be solved **with proper network reinforcements** on the HV Tajik transmission system and the substations transformers, as mentioned in the previous section.

The results of the study are therefore an indication of the system's abilities and limits with regard to the possibility of transporting the exceeding power of the Hydro Power Plants (Rogun) to neighboring countries.

Further analyses with more complete information can be performed in the next phase of the studies, according to what indicated below under "Additional Studies and Tests Required", but the purpose of the present phase is now fulfilled with the analysis contained in this report.

This analysis shows that the critical part of the 500 kV transmission system is located in the north area, mainly related to the connection of SUGHD substation to the other parts of the system. The weakness of this area is indicated by the fact that the export connection SUGHD to the Kyrgyz Republic needs to receive reactive power in SUGHD from the Kyrgyz Republic, although it is not a very long line (477 km), and by the fact that the outage of one single line connecting SUGHD to OBIGARM (Rogun HPP) or DUSHANBE leads to the system collapse. It is therefore suggested to reinforce this part of the system by creating a second line between OBIGARM (Rogun HPP) and SUGHD.

Under N conditions in 2027, with Rogun HPP operating with a rated power of 3,600 MW, and with the Tajik load at its maximum, it would be possible to export through a normal 500 kV power line (2 kA rated current) 1,500 MW to Afghanistan (from YUJNAYA S/S), Kirgizstan (from SUGHD) or Uzbekistan (from REGAR and 2 different alternatives), or to a combination of these destinations, for a total of up to 3,000 MW (or even slightly more), e.g. with 900 MW exported to Afghanistan, 900 MW to Kirgizstan and 1,200 MW to Uzbekistan.

With a peak flow of 1,500 MW for each single line, it is necessary to share the reactive power request of the line (reactive load losses are higher than reactive capacitive losses) between Tajikistan and the importing country for the longest connections (the ones to Uzbekistan). For the connection from SUGHD to the Kyrgyz Republic, as already mentioned, SUGHD needs to receive reactive power in SUGHD from the Kyrgyz Republic, although the line is not very long (477 km), because of the Tajik 500 kV system weakness in the connection to SUGHD.

For a Rogun HPP rated power of 2,800 MW, the export availability is reduced. The export cases of 1,500 MW for each neighboring country are still possible with no reductions, while the global maximum export to multiple countries totals at 2,300 MW.

For a Rogun HPP rated power of 2,000 MW, the export availability is further reduced. The export cases of 1,500 MW for each neighboring country are still possible with small reductions (1,350 or 1,400 MW exports, against 1,500 MW), while the global maximum export to multiple countries totals at about 1,500 MW.

Outages may require export power in some of the possible outages cases, which, once again, demonstrates the weakness of the 500 kV system in the north area.

As for the estimated yearly losses combined with the expected yearly load growth, they rise from 255 to 447 GWh/year between 2013 and 2031, taking into account the assumed reinforcements that surely contribute to improve the system efficiency. For example, in 2025 the value of the losses is reduced compared to previous years and in spite of the load growth, because of the favorable impact of the proposed reinforcement.

### **Additional Studies and Tests Required**

The analysis of the Tajik electrical transmission network was based on the available data as provided by Barki Tojik and is deemed sufficient for the purpose of this phase of the studies.

However, further studies of the electrical network should be carried out before starting the project implementation, for which additional data should be made available, i.e.:

- The monthly sharing of the demand along the year, for which a forecast along a period of about 20 years at least is required;
- Information about the sharing of the forecasted load increase among the various substations. A detailed analysis would require knowing the true redistribution of the loads within the entire Country.
- Updated information about the load growth rate.

## **VOLUME 4: IMPLEMENTATION STUDIES**

# CHAPTER 4.1: IMPLEMENTATION SCHEDULE AND CONSTRUCTION METHOD

## 1 INTRODUCTION

Three alternatives, namely FSL 1290, FSL 1255 and FSL 1220 (FSL means Full Supply Level), are studied in the frame of the Consultant services for the Rogun HPP.

The concept of the project is not to wait for the final completion of the Dam and the HPP for producing energy but to start producing energy at an early stage called **Early Generation** phase. To this end a temporary configuration is set up with the turbines 5 and 6 equipped with temporary generators, except for the alternative FSL 1220 which is implemented since the early commissioning in its final configuration.

During the first impounding, in correspondence of a reservoir water level of 1160 m a.s.l, the commissioning of the UNITS 1,2,3,4 is envisaged to start for the alternative FSL 1290, (while a reservoir water level of 1150 and 1175 m a.s.l shall be attained for the alternatives FSL 1255 and FSL 1220 respectively). For FSL 1290 and FSL 1255 the temporary configuration of the generators of the UNITS 5 and 6 is changed to the final one by adjusting their speed and are re-commissioned after units 1,2,3,4, have been put into commercial operation, while for the alternative FSL 1220 the units are implemented since the beginning in their final configuration.

During the early generation phase, the generating Units 5 and 6 will be fed by a temporary headrace tunnel located downstream of a temporary intake located at elevation 1035 m a.s.l, close to the Diversion Tunnels. The manifolds as well as the tailrace channels for the early generation phase will be maintained even in the final configuration phase. The outlet of the tailrace channels will release the water into the two diversion tunnels DT1 and DT2. A complex system of underground tunnels is required for the accesses and the construction of the powerhouse and the relevant equipment and auxiliary installations. In addition, a consistent number of outlet devices are envisaged for the flood management of the River Diversion and Reservoir, as well as several transportation facilities.



The concept of the underground works and dam body is the same for the three alternatives studied in the frame of the Consultant services, the main differences among the three alternatives lie in the following items:

- Crest dam elevations
- Installed capacity
- Outlet structures for flood discharge facilities

Three implementation schedules, one for each alternative, were studied and are presented in this report.

## 2 CONCLUSION AND RECOMMENDATIONS

In the following list the main assumptions and the conclusions reached during this study are presented:

- two critical paths are detected for the project: one for the early generation phase and one for the dam.
- To meet the target dates of river diversion and of the early generation phase, a substantial amount of works should be completed and/or initiated prior to awarding the main Contract of the Works. This mainly consists of rehabilitation of roads and site installations, cutting access roads to critical structures to start, starting or completing Transport and Access Tunnels, implementing remedial measures for the two Diversion Tunnels (DT1 and DT2) and other underground structures, constructing a third Diversion Tunnel DT3, implementing stabilization measures at the walls of the Powerhouse cavern, excavating and stockpiling shell materials for the Embankment Dam before the river diversion as some borrow areas will be inundated after diversion. It comes out from the proposed Program that these works should be implemented before the River Diversion starting date.
- Several Contractors/Subcontractors of the same trade should be mobilized to meet the requirements of the Program of the Works: Building and Facilities rehabilitation, Civil Works, Roads Works, Tunneling Works, Earthmoving Works, Drilling and Grouting and Geotechnical Works. All these companies should be able to mobilize the required resources in a very short period of time.

- During this pre-contract period in the range of 24 months, the Main Contractor for the Civil Works will be selected and mobilized hence an overlapping between the Main Contract and Pre-Contract is foreseen. The Main Contract duration is 139 months for FSL 1290, while the duration for FSL 1255 and FSL1220 is respectively 118 and 96 months.
- It should be noted that there are several permanent tunnels to carry out in addition to the transport tunnels to be constructed or completed, namely: access tunnels to the top and the bottom elbows of the Penstocks, access tunnel to the drainage gallery at elevation 932 under the 6 tailrace tunnels, one additional river diversion tunnel (DT3), two middle outlet tunnels, two high level tunnel spillways, all with their relevant access tunnels and facilities, in case of the alternative FSL 1290.
- The total length of tunnels to carry out is in the range of 15 km, it should be added 3.6 km of access tunnels to the gate chambers and 2.3 km of drainage galleries. The main tunnels are quite long and of large diameter (10m to 15m) and concrete lined; most of them are crossing adverse geological features. Because of the constraints of the Program of the Works, the tunnels have to be carried from both ends and some tunnels have to be realized in parallel. It is therefore likely that the tunneling activity will need to call more than one contractor specialized in this field of activity.
- River Diversion

According to the River Diversion scheme prepared by the Consultant, three diversion tunnels shall be operational for the Vakhsh Diversion:

- DT1 and DT2 that need to be strengthened
- DT3 that shall be constructed

- Placement rates: a specific study has been performed to justify and differentiate the rates for each dam alternative.
- Taking into account the magnitude of the Works and the target dates for the early generation phase, the duration of the activities of the proposed Program of the Works are based on the availability on site of brand new equipment of high rates of production in sufficient number. The

equipment that cannot meet this requirement should not be allocated to activities which are on the critical path of the Program of the Works.

The main milestones of the Project are summarised hereafter.

**KEY DATES in months counted from the TEAS validation and GoT decision to proceed with the Project**

	Alternative 1290 m asl	Alternative 1255 m asl	Alternative 1220 m asl
<b>TEAS Validation and GoT decision to proceed</b>	0	0	0
<b>River diversion date</b>	28	28	28
<b>End of cofferdam construction</b>	36	36	36
<b>End of stage 1 dam construction</b>	58	53	49
<b>Commissioning of U6 Temp.</b>	73	73	82
<b>Commissioning of U5 Temp.</b>	75	75	84
<b>End of Erection U4</b>	85	85	85
End of Erection U3	98	98	98
End of Erection U2	112	112	112
End of Erection U1	112	112	112
<b>Minimum reservoir level reached</b>	112	94	80
Temp. U5 and U6 shut down	117	114	
<b>Commissioning of U4</b>	115	101	101
<b>Commissioning of U3</b>	117	114	114
<b>Commissioning of U2</b>	119	116	116
<b>Commissioning of U1</b>	121	118	118
Commissioning of U6	123	120	
Commissioning of U5	127	122	
<b>End of dam construction</b>	163	142	120

## CHAPTER 4.2: COST ESTIMATE

### 1 INTRODUCTION

The cost estimate is established for three dam heights and three installed capacities per height. The main focus has been to accurately estimate the cost of the highest height alternative, for which a maximum of documentation was available, and use it as a basis to derive the costs of the lower height dams. The purpose of this estimate is to derive estimates at a relevant level of precision to compare each alternative and feed the economic assessment of the project alternatives.

It includes estimates for remedial measures to strengthen existing structures as recommended in the Phase I report, and mitigation measures for salt dissolution specified in the Phase 0 report. All Environment and Social costs, as estimated by the ESIA Consultant, were duly incorporated in the overall estimate.

The unit price analyses and the cost summaries have been elaborated in United States of America Dollars (US\$), with a breakdown into local and foreign currency

The details related to the cost estimate methodology are given in the eight parts composing the relevant Volume.

For confidentiality reasons, the cost estimate figures are not disclosed in the present document. Hereafter are given the relative price of each alternative compared to the alternative 1220 masl / 2000 MW:

Height (masl)	Installed Capacity (MW)	Investment cost (USD million)
1290	3,600	157%
	3,200	154%
	2,800	152%
1255	3,200	132%
	2,800	130%
	2,400	128%
1220	2,800	105%
	2,400	102%
	2,000	100%

## 2 METHODOLOGY

### 2.1 Project Costs

The project costs related to the civil works and permanent equipment are detailed in the priced Bill of Quantities organized as follow:

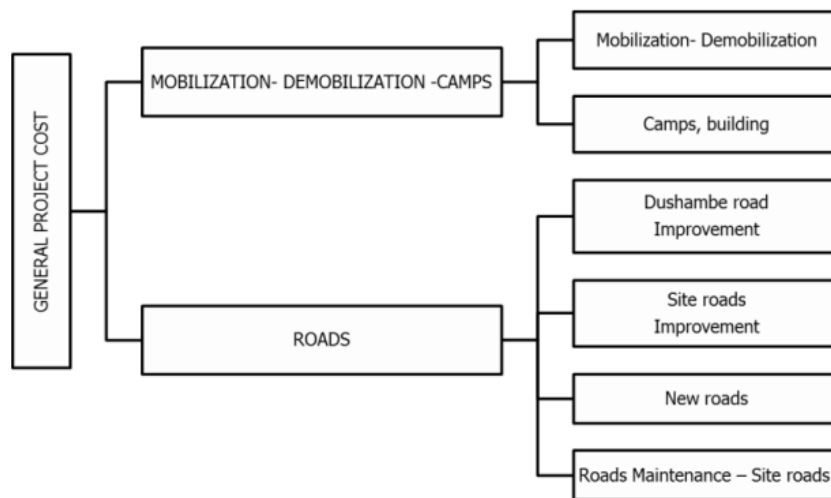

**Figure 56: Cost Estimate – Phase II, diagram**

(\*) Phase I: Existing Works; Phase II: Works to be achieved; E&M: Electro and Mechanical Equipment; HSS: Hydro Mechanical Equipment; TL/SS: Transmission lines and Substation bay.

The total amount of the project (use as input data for Economic and Financial Analysis) is calculated as follow:

$$\begin{aligned}
 & (1) [\text{Civil Works} + \text{Permanent Equipment}] * (2) [\text{Physical Contingencies}] = (3) \\
 & + (4) [\text{Administration and Engineering Cost}] \\
 & + (5) [\text{Environmental \& Social Costs}] \\
 & = \text{TOTAL AMOUNT OF THE PROJECT}
 \end{aligned}$$

Administration and Engineering Costs are calculated as percentages of (3): Administration (2%) and Engineering (2%).

## 2.2 Costs not Included in the Estimate

The Project cost estimates do not include the following costs:

- Land acquisition and rights of way (both permanent and temporary).
- Interests during construction;
- Taxes, duties and levies in Tajikistan, except for the Contractor's Income Tax.

## 2.3 Physical Contingencies

Physical contingencies have been considered, according to an analysis for each specific item (Civil works, Permanent equipment).

The mean resulting value of physical contingencies is close to 11% of the cost without these contingencies.

## 2.4 Estimation Methodology

### 2.4.1 Civil Works

The price analyses carried out take the following main components into account:

- Basic wages of labor;
- Basic costs of materials delivered to the Site;
- Owning and operating costs of the construction equipment;
- Site construction contingencies;
- Overheads and profit.

### 2.4.2 Permanent Equipment

The costs have been determined by considering to utilize the items already available to the maximum possible extent, except for the two existing runners, which are not to be used since at the time of their commissioning the reservoir elevation will be such to allow installing the final runners

Various approaches can be implemented to evaluate the costs of E&M equipment.

Apparently, the most precise one would be to evaluate in detail the cost of all major components by separately estimating their manufacturing costs from their transportation and erection costs.

At this stage of the project, a detailed analysis of the cost of all single main components would be unjustified and could even lead to some cost evaluation errors which could be larger than these made with the procedure adopted by the Consultant, which is applicable when there is a large installed capacity and when various units are foreseen.

Therefore, the Consultant has calculated the E&M costs on the basis of cost per kW, evaluating separately the turbine, generator and remaining equipment costs (Balance of Plant - BOP).

The calculation of HSS cost (gates, penstock, linings) is not strictly dependent on the installed capacity (as the cost of spillway gates is related to the design flood), and has been performed by evaluating separately the costs of the various main components.

### **3 DAM CONSTRUCTION ASSUMPTIONS**

#### **3.1 Introduction**

The Phase II Cost Estimate includes all the works to be done for the completion of the Rogun hydroelectric power plant such as the dam, power facilities, spillways, outlets and additional diversion tunnels. The works executed since 1980 and prior to the end of the Soviet Union are included in the Phase I Cost Estimate.

The aim of this paragraph is to give the main assumptions taken into account for the calculation of quantities and unit prices.

The purpose of this approach is to derive representative overall cost estimates for each alternative at the feasibility level. Comprehensive Method Statements of the works will be prepared at the detailed design stage by the Engineer of the project.

#### **3.2 Roads**

The cost estimation of roads has been taken into account in the Cost Estimate, with the rehabilitation of existing roads (improvement, enlargement) and the cost of building of new roads.

### 3.3 Contractor's Camps and Temporary Buildings

The Phase II Cost Estimate is based on the assumption that the dam construction with the appurtenant works is carried out by contractors who are fully responsible for the supply, installation, maintenance and removal of both the camps and the temporary buildings necessary for their activities and these of their subcontractors.

### 3.4 Borrow Areas and Quarries

The borrow areas and quarries considered for dam fills are detailed in Vol. 3, Ch. 3 – Appendix 1: "Construction Material Assessment".

### 3.5 Stockpile Areas for Dam Embankment

The methodology considered for the dam construction is based on the assumption that all stockpiled material is used for the embankment. The following table gives the quantities already extracted and stockpiled.

	<b>LG1 (Alluvium shell)</b>	<b>LG2 (Alluvium shell)</b>	<b>LG2 (Filters)</b>	<b>LL3 (Loam)</b>
<b>Extracted</b>	14,6	7,5	4,0	2,5
<b>Placed in dam</b>	13,3	6,8	4,0	2,5

**Table 70 : Quantities Available in Stockpiles, [Mm3]**

The table above shows the coefficient considered between the extracted volume and its placement in the dam in the case of Alluvium shells. The volumes are assumed to be identical for Filters and Loam.

The quantities available in Lyabidora have been reviewed, and fully exploited and stockpiled in LG2. The remaining quantity that is needed has to be extracted from BA15.



### 3.6 Dam Fills

#### 3.6.1 General Description of Dam

The typical longitudinal cross section below shows the different materials which constitute the dam fills: Core, Fine Filter, Coarse Filter, Alluvium shell, Rockfill shell, Riprap, Concrete Foundation and Bituminous Core.

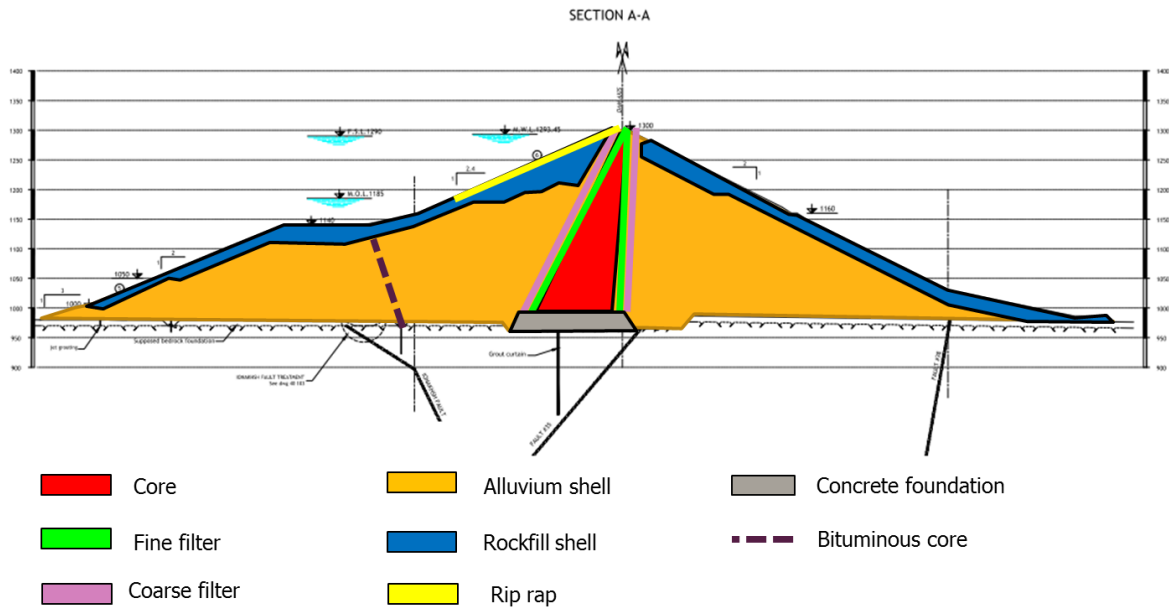

**Figure 57: Typical Longitudinal Cross Section of Dam**

The quantities for each material and alternative are summarized in the following table.

Material		FSL 1290	FSL 1255	FSL 1220
1	Alluvium shell	43.06	33.18	18.92
2	Rockfill shell	17.37	12.48	9.35
4	Core (Loam + Fine)	6.99	5.10	3.71
5	Fine Filter	2.47	1.35	0.75
6	Coarse Filter	3.15	2.03	2.00
7	Riprap	0.55	0.37	0.30
8	Bituminous Core	0.024	0.020	0.018
9	Concrete foundation	0.354	0.329	0.308

**Table 71 : Materials Quantities for each Alternative, [Mm3]**

The unit price for each material (considering extraction / stockpile / process / transport and placing) has been differentiated for 6 phases presented in Figure 58.

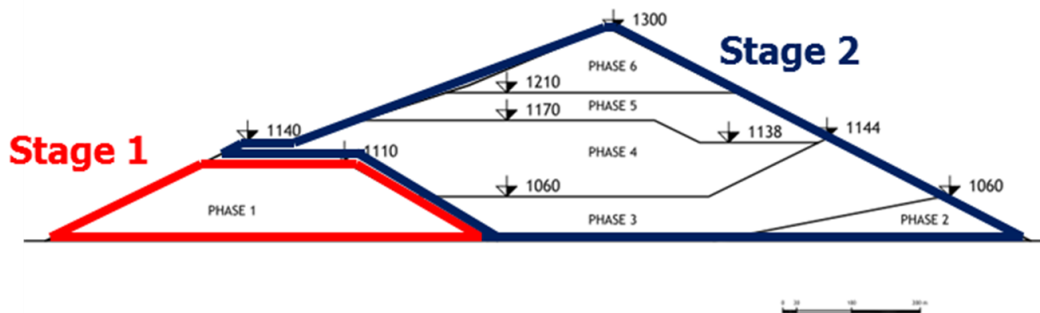

**Figure 58: Dam Phasing - Longitudinal Cross Section**

The main reasons of this consideration are:

- The dam elevation has a non-negligible influence on the unit price, because of the transport length along the consequent slope to raise the dam face, and the narrowing of the dam crest which limits the traffic of trucks for placing.
- The reservoir filling is taken into account, and the materials have to be extracted before the borrow areas/quarries are underwater. It is sometime necessary to stockpile the material in anticipation.

### 3.6.2 Sources and Quantities of Materials

This paragraph presents the source of materials and the corresponding quantities extracted, for each material, phase and alternative.

### 3.6.2.1 Alternative FSL=1290 m a.s.l

Material		Phase 1	Phase 2	Phase 3	Phase 4			Phase 5	Phase 6
1	Alluvium shell	BA15	BA15	BA15	BA15	LG1	LG2	LG1	BA15
2	Rock shell	Q26	Q26	Q26	Q26			Q26	Q26
4	Core (Loam)			LL3	BA17			LL3	BA17
5	Transition layer 1	BA15		LG2	LG2	BA15		BA15	LG2
6	Transition layer 2	BA15		LG2	LG2			BA15	LG2
7	Rip rap							Q26	Q26

**Table 72: Alternative 1290 - Sources**

Material		Phase 1	Phase 2	Phase 3	Phase 4			Phase 5	Phase 6
1	Alluvium shell	10,497,251	2,418,575	6,935,810	1,910,503	6,568,967	6,815,900	6,735,233	1,181,625
2	Rock shell	2,016,210	935,035	1,077,240	2,606,935			4,119,019	6,610,620
4	Core (Loam + Pure Clay)			1,567,260	3,209,040			996,115	1,220,075
5	Transition layer 1	88,890		372,840	207,405	435,740		385,270	976,510
6	Transition layer 2	177,780		469,145	976,120			503,930	1,027,980
7	Rip rap							129,790	424,885

**Table 73: Alternative 1290 – Quantities [m3]**

### 3.6.2.2 Alternative FSL=1255 m a.s.l

Material		Phase 1	Phase 2	Phase 3		Phase 4	Phase 5		Phase 6
1	Alluvium shell	BA15	LG2	BA15	LG2	LG1	LG1	BA15	BA15
2	Rockfill shell	Q26	Q26	Q26		Q26	Q26		Q26
4	Core (Loam)			BA17		LL3	BA17	LL3	BA17
5	Fine Filter	LG2		LG2		LG2	LG2		LG2
6	Coarse Filter	LG2		LG2		LG2	LG2		LG2
7	Rip rap						Q26		Q26

**Table 74: Alternative 1255 - Sources**

Material		Phase 1	Phase 2	Phase 3		Phase 4	Phase 5		Phase 6
1	Alluvium shell	8,088,672	1,863,636	392,135	4,952,264	11,785,869	1,518,331	3,671,512	910,503
2	Rockfill shell	1,448,445	671,729	773,889		1,872,821	2,959,102		4,749,067
4	Core (Loam + Fine)				1,144,100	2,342,599	569,763	157,401	890,655
5	Fine Filter	48,657			204,085	352,044	210,889		534,521
6	Coarse Filter	114,588			302,386	629,156	324,807		662,582
7	Rip rap						86,257		282,372

**Table 75: Alternative 1255 – Quantities [m3]**

### 3.6.2.3 Alternative FSL=1220 m a.s.l

Material		Phase 1	Phase 2	Phase 3	Phase 4		Phase 5	Phase 6
1	Alluvium shell	LG1	LG1	LG2	LG2	LG1	LG1	LG1
2	Rockfill shell	Q26	Q26	Q26	Q26		Q26	Q26
4	Core (Loam)			LL3	LL3		BA17	BA17
5	Fine Filter	LG2		LG2	LG2		LG2	LG2
6	Coarse Filter	LG2		LG2	LG2		LG2	LG2
7	Rip rap						Q26	Q26

**Table 76: Alternative 1220 - Sources**

Material		Phase 1	Phase 2	Phase 3	Phase 4		Phase 5	Phase 6
1	Alluvium shell	4,613,063	1,062,853	3,047,972	3,767,928	2,953,690	2,959,828	519,270
2	Rockfill shell	1,085,877	503,585	580,173	1,404,026		2,218,395	3,560,305
4	Core (Loam + Fine)			832,600	1,704,788		529,181	648,159
5	Fine Filter	26,942		113,007	194,936		116,774	295,978
6	Coarse Filter	112,718		297,452	618,889		319,506	651,769
7	Rip rap						70,804	231,785

**Table 77: Alternative 1220 – Quantities [m3]**

### 3.6.3 Transport

#### 3.6.3.1 Types of Transport

Transport has a big influence on the unit price of each material. A detailed analysis has been carried out in order to optimize transport, by taking into consideration each constraint (transport length, reservoir filling, availability of road or belt conveyor system, traffic, etc.).

Two types of transport have been considered to carry material in dam:

- Trucks (for each transport which cannot be done by the belt conveyor system).
- Belt conveyor system (from loading station 1 or 2).

Transport by truck is unavoidable for Dam Phase 1 of construction (the belt conveyor system is not yet available); to carry material up to stockpiles/loading stations, from the belt conveyor service yard to the dam, or from the area located downstream or in the right bank.

The belt conveyor system is presented in Figure 59.

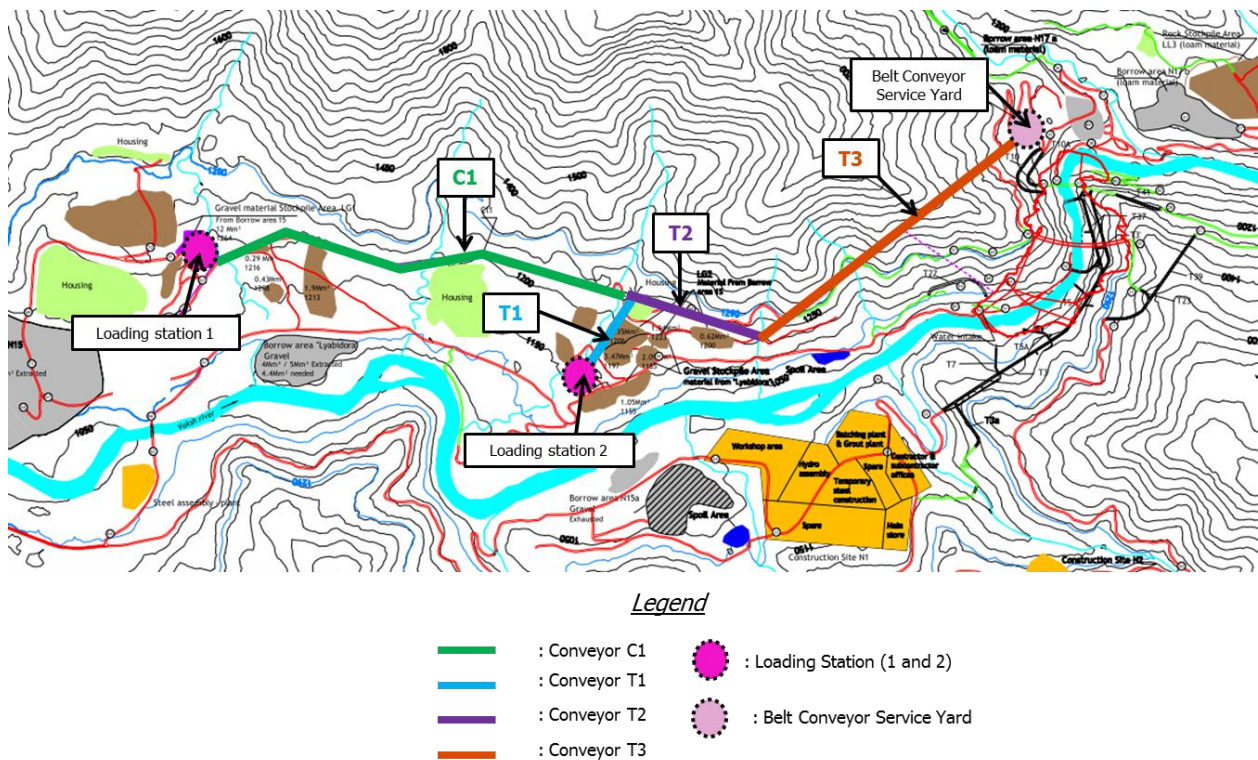

**Figure 59: Belt Conveyor System**

### 3.6.3.2 Transport Steps

Each transport step has been estimated for alternative FSL=1290 m a.s.l. The basic costs have been reused correctly for alternative FSL=1255 m a.s.l and FSL=1220 m a.s.l considering the transport steps defined for each alternative.

Figure 60 summarizes the methodology used for unit price calculation.

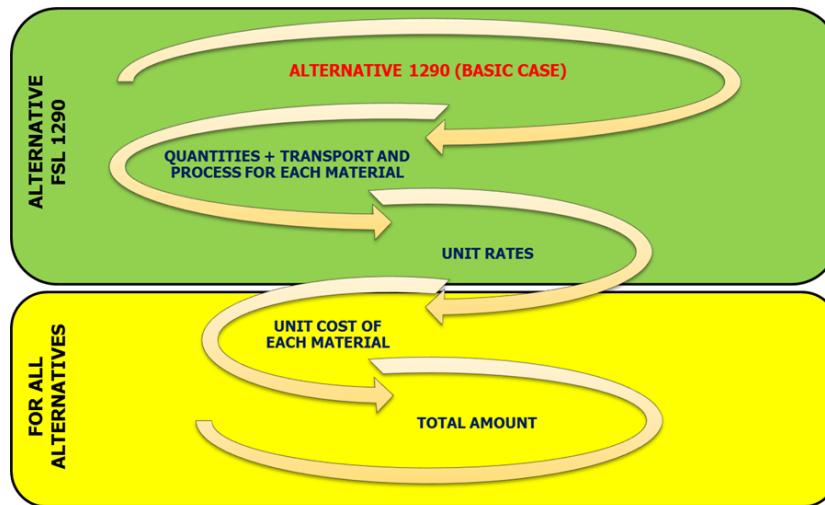

Figure 60: Dam fills – Unit cost methodology.

### 3.6.4 Material Processes

The different processes identified are:

- Filter processing from LG2 and BA15.
- Pre-blasting of weak and medium interlayers of cemented BA15 alluvium.
- Blasting of Rockfill shell from Q26.
- Screening of materials from LL3.
- Care of water and material processing in borrow area for moisture control.

These processes have been estimated and included in the unit cost of each material.

### 3.7 Other Works

For dam construction, other works have been estimated and included in the Cost Estimate – Phase II:

- Grout curtain for Stage 1 and Stage 2.
- Ionakhsh fault treatment: Hydraulic curtain and grout curtain.
- Dam excavation.

- Protection and reinforcement of dam excavation.
- Breakwater on dam crest.

#### 4 DISBURSEMENT CURVES

The Capex disbursement curve gives the repartition of the total amount year by year. At this stage of the study, it is not possible to establish a precise Capex disbursement curve, but the Consultant proposed its own cost distribution based on its experience of large hydro project and the analysis of the implementation schedule.

The methodology is to determine the amount spent by year from the beginning to the end of the works. In this way, the main items of the Cost Estimate have been identified. The amount of these items is thereafter distributed considering the starting and the ending date.

It has been decided to calculate the Equivalent disbursement curve based on disbursement curves derived for the following items:

- Civil Works (General project Cost, Dam works, Underground Works);
- Permanent Equipment (E&M, HSS, TL/SS);
- Administration and Engineering;
- Infrastructure Replacement and Resettlement Costs (from the ESIA Report).

This was an important input to the economic and financial analysis.

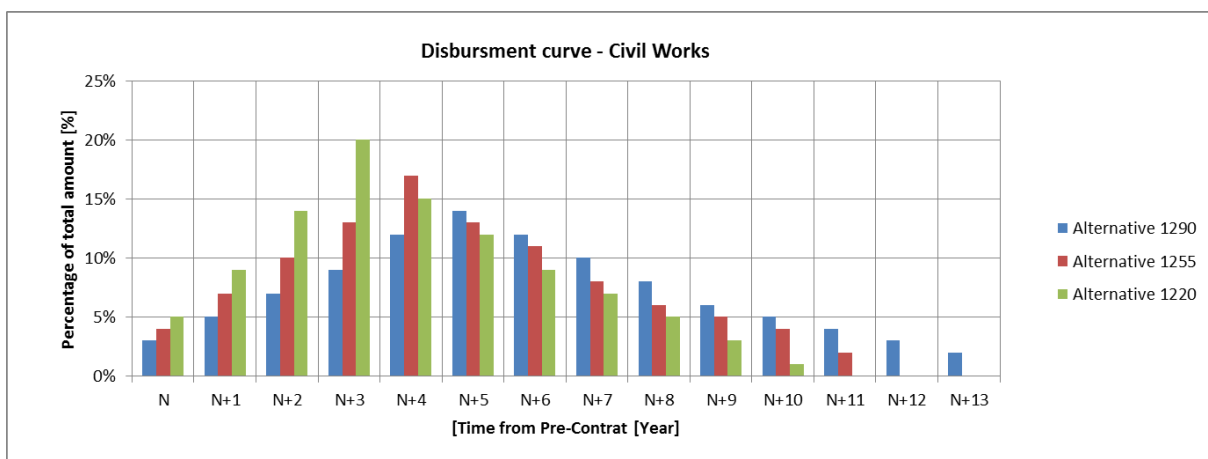

Figure 61 : Disbursement curve - Civil Works

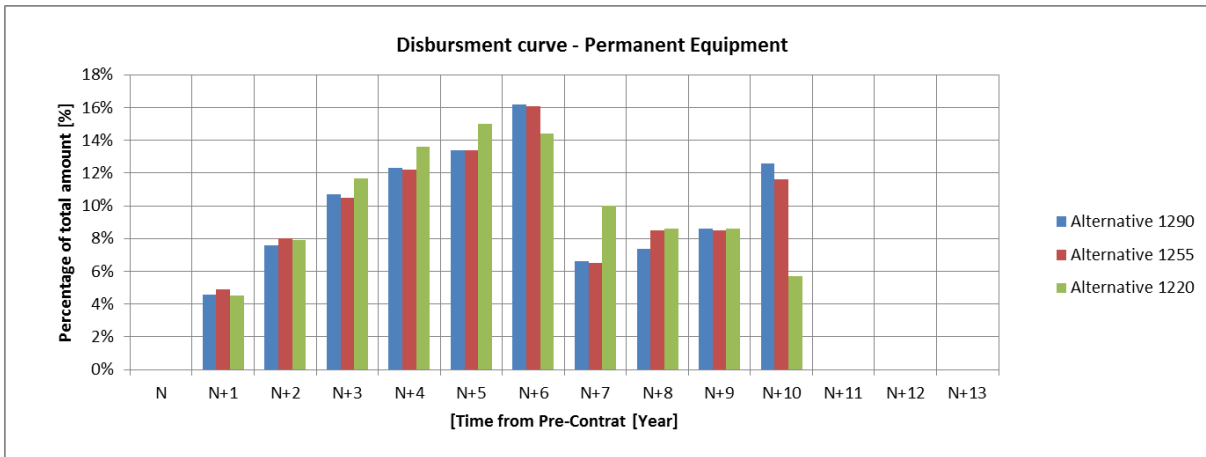

Figure 62 : Disbursement curve – Permanent Equipment

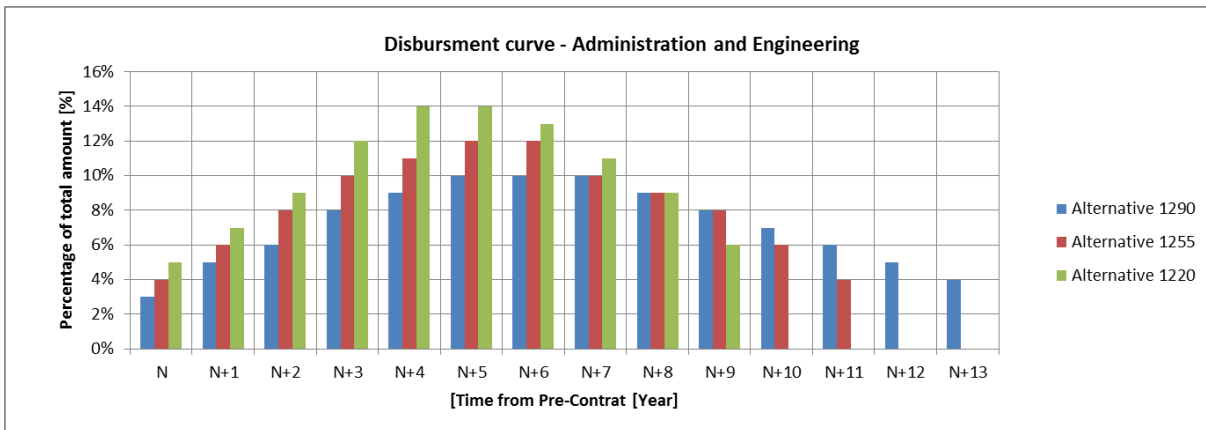

Figure 63 : Disbursement curve - Administration and Engineering

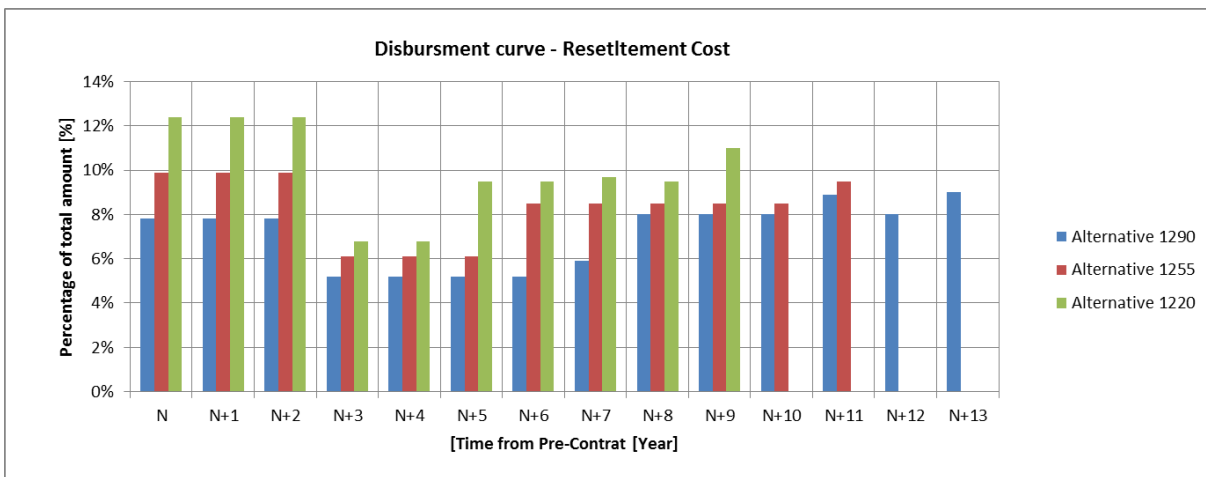

Figure 64: Disbursement curve – Infrastructure Replacement and Resettlement Costs



# **VOLUME 5: ECONOMIC AND FINANCIAL ANALYSIS**

## CHAPTER 5.1: ECONOMIC ANALYSIS

### *Introduction*

This chapter summarises the methodology, assumptions and results of the economic analysis, considering nine possible Rogun design options, comprising combinations of the three different dam heights each with three total installed generation capacities. Based on these results, and the outcome of the technical studies, one specific design option is recommended by the Consortium to be taken forward for detailed consideration, and additional analysis has been incorporated on the economics of this preferred option.

It should be noted that that all monetary figures referred herein are in real terms with 2013 as the base year, and United States Dollars (“USD”) as the default currency, unless otherwise stated.

### *Methodology*

We prepared a regional least-cost generation expansion plan for each of the nine Rogun design options and also for an option excluding Rogun, based on assumptions for Tajikistan and neighbouring countries using our proprietary power market model, ECLIPSE®, and from this quantified the Total System Costs (“TSC”) in the interconnected Central Asian Power System (“CAPS”) for each of these options. We assessed the economic benefit of each option by evaluating the impact on the Present Value (“PV”) of TSC in Tajikistan, and thereby determined the least-cost option for Tajikistan. We then also prepared stand-alone economic analyses for the different designs of the Project in terms of their Net Present Value (“NPV”) and Economic Internal Rate of Return (“EIRR”), using the results of the least-cost analyses.

***Regional least-cost generation expansion plan:*** The least-cost analysis extends from 2013 to 2050 (the “Forecast Horizon”) with ECLIPSE seeking the solution that meets all constraints over this 38-year period. ECLIPSE builds capacity and dispatches power plants in Tajikistan and the neighbouring countries with the aim of satisfying demand at the minimum TSC for the interconnected region. The TSC includes annualised capex repayments, fixed and variable O&M costs, fuel costs and the cost of using interconnectors. The model allows for electricity to be transferred between interconnected countries based on the Net Transfer Capacity (“NTC”) of the interconnection lines. The import-export flows are determined by the difference between marginal generation costs and the supply-demand situation in each country.

**Total System Cost saving comparison:** In order to assess the Project's value to the Tajikistan power system, we calculated the total system cost savings from the start of construction of the Project, by comparing the TSC under the following two scenarios:

- No Rogun: A least-cost expansion plan analysis which excludes the Project to determine the benchmark capacity expansion plan and potential exports.
- With Rogun: Similar least-cost expansion plans assuming that each of the Rogun design options is built on a firm basis.

The option that provides the largest estimated cost saving is considered to be the least cost option for Tajikistan. System cost savings are calculated in PV terms in 2013 at a 10 percent discount rate.

The construction of Rogun may also provide flood protection to the entire downstream Vakhsh cascade, depending on the design option selected. Since these benefits are inherent in the system costs for those designs, for a proper comparison, it was necessary to include the costs of providing similar flood protection benefits in the TSC for the No Rogun case and any of the Rogun design options which do not confer this benefit. There has been a considerable amount of preparatory work already undertaken at the Rogun site, and in the event that the Project does not proceed, the construction site would have to be safely decommissioned. The cost of doing so has been estimated and included in the TSC for the No Rogun case.

The technical lifetime of the Project depends on the time for the reservoir to fill with sediment and hence on the available reservoir capacity for each dam height option. The lifetime has been determined as 45 years for the smallest dam height (1,220 metres above sea level ("masl")), 75 years for the medium dam height (1,255 masl) and 115 years for the largest (1,290 masl). The long project lifetime exceeds the timeframe of a meaningful least-cost planning analysis. Therefore, in order to reflect the long-run benefits of the Project, we have also calculated the post-2050 value as the PV of the annual savings from 2050 to the end of the projected technical life. We have not used the common run-out approach that the savings in the last modelled year continue to the end of the Project's life, because this implicitly assumes that the costs of new build to meet demand growth and replace existing plant as they close are identical with or without the Project, and hence there are no net savings. However, because increasing sedimentation will tend to reduce the output from the Project, and hence its benefit, towards the end of its life, we have instead assumed that the annual savings in 2050 drop in a linear manner to zero at the end of the projected technical lifetime of the option under consideration. Since in reality the effect of

sedimentation will be more gradual and significant only in the last few years of the Project's life, this provides a conservative estimate for the benefits of the Project options.

**Economic analysis:** The second assessment of the viability of Rogun was via an economic analysis consisting of a comparison of benefits versus costs for each Rogun design option. Economic costs are determined on the same basis as in the TSC savings analysis. The economic benefits reflect how the economy of Tajikistan improves as a direct result of the increase in power and energy generation due to the implementation and operation of the selected Rogun option, and indirectly from other consequences of Rogun's implementation. This second stage analysis has thus taken into account both direct financial benefits accruing from the sale of electricity generated as well as wider societal economic benefits arising from its construction and operation.

The economic value of electricity generated by Rogun arises from both meeting domestic demand and exporting via interconnectors to neighbouring countries. The economic value of these sales was calculated using the marginal (avoided) cost of generation determined by ECLIPSE. For the dam options which provide flood prevention benefit, we have also incorporated the estimated avoided costs of providing similar flood protection in the absence of the Project as additional Project benefits in the economic analysis for those design options which confer this downstream protection.

The Project's costs include the costs for civil works, hydro-mechanical, electromechanical, and transmission line sub-station equipment costs (including transmission), administration and engineering costs, resettlement and infrastructure replacement (environmental costs), O&M costs, as well as the annual value of lost agricultural production from land impacted by the reservoir.

**Probability-weighted sensitivity analysis:** In order to account for the uncertainty around the inputs used for the least-cost expansion planning, sensitivities were used to assess the robustness of the estimated cost savings and the economic value of each Rogun design option to variations in economic and other conditions. The sensitivities considered in our analysis cover changes in four variables which we identified as likely to have a large impact on TSC:

1. **Demand:** Electricity demand growth scenarios for Tajikistan.
2. **Fuel costs:** Fuel price assumptions for Central Asia including Tajikistan.

3. **Total Investment Costs (“TIC”)**: The TIC of the New Build options, including the different candidate plants in Tajikistan and neighbouring countries whilst keeping inputs for the Project unaffected.
4. **NTC**: Capacity of the interconnectors from Tajikistan to Pakistan, Kyrgyzstan and Uzbekistan.

Central, high and low cases were determined for each variable, with estimated probabilities of occurrence of 50%, 25% and 25% respectively. The Reference case assumed the central forecast for all variables, and eight sensitivities were examined varying each variable in turn to its high and low value. The relative probability of occurrence of each sensitivity case is thus half of the Reference case, and overall probability-weighted average TSC savings and economic NPVs for each Rogun design option were calculated on this basis.

### **Key Assumptions**

Tajikistan has some coal deposits but relies on Hydroelectric Power Plants (“HPP(s)”) to supply the majority of its electricity. Most of the country’s HPP capacity, including the 3,000MW Nurek Dam, is located on the Vakhsh River, the flow of which is primarily driven by seasonal glacial and snow melting. Flow rate and thus HPP generation is thus highest in the summer and falls significantly in the winter. Although some water can be stored in reservoirs to power the HPPs during winter, the lower flow rate results in much lower generation levels.

**Demand forecast.** Electricity demand in Tajikistan peaks in winter, largely for space heating during the coldest months. However, the mismatch caused by greater electricity generation in summer and higher demand in winter results in summer surpluses and winter shortages. The severity of unserved winter demand in Tajikistan becomes particularly obvious when looking at the monthly electricity consumption data. Recent winters have seen up to 50% of demand remaining unserved in the worst affected months. The unserved part of demand is suppressed by means of load shedding, which translates into cutting off the supply to certain parts of the grid (mostly residential) for a certain period of time.

The true (unconstrained) demand cannot be directly observed. Unserved demand must be estimated and added to served demand (for which data is available) in order to estimate the true demand (unconstrained demand) in any given year. However, not all parts of the economy are equally affected by supply shortages, with aluminium production and agriculture less affected.

We conducted a detailed analysis on future electricity demand and gross generation requirement in Tajikistan, considering the potential future impact of both economic growth and electricity tariffs on consumption as well as expected developments in the country's electricity system to reduce transmission and distribution losses, and considering a range of estimates for unserved demand. The median compound annual growth rate ("CAGR") to 2050 was forecast at 2.6%, while the 25<sup>th</sup> and 75<sup>th</sup> percentiles which form the basis of our low and high sensitivities range from 2.0% to 3.6%.

***New build options:*** In the least-cost expansion modelling, we have considered several specified and generic run-of-river ("ROR") and dam hydro projects, including the various Rogun options and the 4,000MW Dashtijum dam, as new build options determined by the model according to economic merit. Taking fuel resources and availability in Tajikistan into account, we allowed new coal-fired plants to be built but did not allow for any new domestic gas-fired generation in the base case. Tajikistan has limited potential for renewables such as wind, geothermal, waste-to-energy, and solar PV, and so these technologies have not been considered as significant capacity expansion options for the modelling.

***Interconnection with neighbouring markets:*** The CAPS, developed under the Soviet Union, comprises the national grids of Tajikistan, southern Kazakhstan, Kyrgyzstan, Turkmenistan and Uzbekistan. The system was planned to function in an integrated model which allowed for exchange of power across these countries dependent on differences in their respective energy resources and seasonal demand and supply for electricity and water.

Although Tajikistan and Kyrgyzstan, the two upstream countries, have very little gas and oil reserves, the downstream countries, Uzbekistan and Turkmenistan, and Kazakhstan enjoy huge proven reserves of these fuels. On the other hand, Tajikistan and Kyrgyzstan benefit from substantial hydroelectric potential. Furthermore, summer water releases by the upstream countries are critical for irrigated agriculture in the downstream countries. As a result, in the winter, Tajikistan and Kyrgyzstan would rely on fuel and power imports from their neighbours, and in the summer they would release water. Since the break-up of the Soviet Union and without a single coordinating political and economic ethos, competing national interests resulted in a shift towards uncontrolled outtakes of electricity from the regional grid, an emphasis on securing supply from national sources alone, and the eventual withdrawal from the CAPS of Turkmenistan in 2003 and Uzbekistan and Kazakhstan in 2009.

For our base case modelling, we assume there are no electricity interconnections between Tajikistan and Uzbekistan. We consider the CASA-1000 transmission line which is expected to connect Tajikistan and Kyrgyzstan to Pakistan via Afghanistan by 2017 with a capacity of 1,000MW. There is an existing interconnection between Afghanistan and Tajikistan with an NTC of 110MW. The CASA-1000 project will also increase this capacity by a further 300MW.

In addition to the existing and known planned interconnections, we also allowed for potential new interconnectors between Tajikistan, Kyrgyzstan and Pakistan to be built on an economic basis according to the relative generation economics in the neighbouring countries.

Pakistan is a relatively large power market with maximum demand in the summer, currently experiencing capacity shortfall year round. As a result of the significant summer shortfall and high cost of generation in the country, Pakistan is a very likely export market for Tajikistan's hydro power. Afghanistan too has a very low electrification rate and currently experiences a large capacity shortfall and is therefore reliant on imports. Kyrgyzstan has significant hydroelectric potential and it is estimated that the country has so far only exploited around 10% of its hydroelectric potential and its power sector very much resembles that of Tajikistan. Whilst it is less likely that Kyrgyzstan will have power shortage during summer months when hydro availability is higher, as in Tajikistan, its interconnections with Uzbekistan and Kazakhstan provide alternative routes for power to be transmitted to and from these countries.

### ***Least-Cost Generation Expansion Results***

The results from the least-cost expansion modelling in all cases (No Rogun and the Rogun design options) indicates the need for the construction of at least one large dam (Rogun or Dashtijum) along with several new ROR HPPs. Tajikistan would also need to rely on imports from (or through) Kyrgyzstan to fully meet winter demand.

The main difference between the capacity mixes under the various Rogun design options is the amounts of capacity and the timing of the deployment of new build. The fact that Rogun will be upstream of the existing HPPs in the Vakhsh river both improves the total output from the Vakhsh cascade and allows a very large range of controllable generation from Rogun, even within the constraint of abiding by existing agreements and practices on summer water releases downstream. The other large dam option, Dashtijum, does not enjoy this benefit, and thus in the No Rogun scenario a much larger amount of Hydro ROR would need to be built. This higher capacity also results in a greater surplus of summer energy, which would require a greater total level of

expansion of interconnectors in the No Rogun case than for Rogun to maximise the value to the region as a whole.

Once the construction of the Project begins, the forecast cost of electricity tends to be lower under the Rogun design options than under the No Rogun scenario. Towards the end of the Forecast Horizon, the annual electricity cost in Tajikistan under the Rogun design options stands at just under 100USD/MWh.

Electricity exchanges between countries are broadly similar in all cases. Tajikistan is expected to become a net exporter under all scenarios, exporting to Pakistan and Afghanistan during summer and importing from (and through) Kyrgyzstan in winter. The largest volume of exports is to Pakistan, with the export interconnectors almost fully utilised in the summer when electricity demand in Pakistan peaks and Tajikistan has surplus energy. By contrast, power demand in Tajikistan's other neighbours peaks in winter which limits Tajikistan's opportunities for exporting to them in summer.

### ***Total System Cost Savings***

Table 79 below shows the PV of TSC savings for the Reference case and eight sensitivities, as well as the resulting probability-weighted average. All of the Rogun options provide significant system cost savings in the later years predominantly as a result of the amount of New Hydro ROR build required in the No Rogun case.

The results show that all the Rogun design options would have an overall beneficial impact on the Tajikistan electricity system across all sensitivities, from 69USD million for the smallest Rogun option with High Demand growth to over 2.5USD billion for the highest dam height options in the High TIC case. The highest dam option (1290 masl) generally shows the greatest benefit across all sensitivities, except in the Low Demand growth case when the lower need for capacity makes the smaller dam options more appropriate. In practice, if demand were forecast to grow less quickly, new build might be deferred or result in an adjustment in the implementation schedule of the Project.

Comparing the sensitivity results to the Reference case, we can note the following impacts:

1. **Demand:** The net benefit of all the Rogun options would be reduced if demand growth is lower than forecast, reflecting the unnecessarily early capital expenditure on new capacity. If demand growth is higher though, the lower capacity options also provide a smaller net benefit compared to the larger Dashtijum option in the No Rogun case because of the need



for additional new build to meet the higher demand. The highest capacity options do provide an increased benefit because they contribute a significant level of generation earlier than the assumed firm start date for Dashtijum.

2. **Fuel costs:** Lower fuel costs for thermal generation alternatives would reduce the net benefit of all Rogun options, while higher costs increase the benefit from the two higher dam height options. The lowest dam height options actually show small reductions in cost savings because smaller export volumes displace more expensive thermal generation in neighbouring countries first. (As export volumes rise, the next tranche of foreign generation to be replaced would be less expensive than the previous one.)
3. **TIC:** Higher costs of alternative capacity options naturally increase the benefit from the Project, while lower costs reduce it.
4. **Interconnection:** Reducing the potential for exports by limiting interconnector expansion means that the benefit from exports to Tajikistan is reduced. However, the high interconnector case shows a similar reduction in cost savings because the interconnection with Uzbekistan and increased connection to Kyrgyzstan enable greater imports which reduce domestic Tajik electricity costs, and hence reduce the need for earlier generation from Rogun compared to Dashtijum.

### ***Economic Analysis***

For the economic analysis, the benefits of the Project consist of the value of Project's generation for domestic use and for exports, and the flood protection which the two higher dam heights provide for the downstream Vakhsh cascade. The NPV results shown in Table 79 indicate that the higher initial costs of the higher dam options are outweighed by the future benefits including the external benefits of flood prevention.

The highest dam height options have the greatest NPVs across all the sensitivities. Comparing the sensitivity results to the Reference case, we see a similar trend as with the TSC savings:

1. **Demand:** Lower demand growth reduces the value of all Rogun options because domestic prices are lower. The construction of additional ROR Hydro in the higher demand sensitivity increases realised prices.

2. **Fuel costs:** High fuel prices lead to higher costs in Tajikistan's thermal-based neighbours and thus increase the value of exports and the NPV of Rogun, with the opposite when fuel prices are lower.
3. **TIC:** Increasing the cost of non-Rogun new build options increases prices and the value of exports, and vice versa.
4. **Interconnection:** In the low interconnector sensitivity, the loss of exports to higher-priced Pakistan leads to a drop in export revenue and hence a lower NPV. NPVs are also reduced in the High NTC sensitivity because of the downward impact on domestic prices of greater imports from Uzbekistan and Kyrgyzstan.

**Table 78: PV of TSC savings by sensitivity @ 10%**

Case (prob.)	Reference	High Demand	Low Demand	High Fuel	Low Fuel	High TIC	Low TIC	High NTC	Low NTC	Probability-weighted average
USD million	20%	10%	10%	10%	10%	10%	10%	10%	10%	
1290, 3600 MW	1,678	1,854	628	1,881	1,215	2,509	554	1,051	1,485	<b>1,453</b>
1290, 3200 MW	1,707	1,825	679	1,929	1,238	2,531	560	1,072	1,542	<b>1,479</b>
1290, 2800 MW	1,701	1,452	688	1,897	1,248	2,522	538	1,071	1,552	<b>1,437</b>
1255, 3200 MW	1,495	1,687	621	1,729	1,103	2,399	580	948	1,353	<b>1,341</b>
1255, 2800 MW	1,497	1,344	648	1,739	1,099	2,410	529	944	1,436	<b>1,314</b>
1255, 2400 MW	1,524	468	635	1,672	1,106	2,395	541	937	1,380	<b>1,218</b>
1220, 2800 MW	1,389	1,432	723	1,381	983	2,047	356	936	1,111	<b>1,174</b>
1220, 2400 MW	1,387	728	734	1,315	980	2,034	348	927	1,155	<b>1,100</b>
1220, 2000 MW	1,342	69	710	1,329	933	1,980	424	866	1,228	<b>1,022</b>

**Table 79: NPV @ 10% of different Rogun design options across sensitivities**

Case (prob.)	Reference	High Demand	Low Demand	High TIC	Low TIC	High Fuel	Low Fuel	High NTC	Low NTC	Probability-weighted average
USD million	20%	10%	10%	10%	10%	10%	10%	10%	10%	
1290,3600 MW	819	852	720	1,080	523	1,222	366	766	780	<b>795</b>
1290, 3200 MW	863	887	765	1,121	559	1,244	420	808	819	<b>835</b>
1290, 2800 MW	878	792	769	1,132	561	1,251	405	820	767	<b>825</b>
1255, 3200 MW	729	768	648	951	460	1,074	302	663	667	<b>699</b>
1255, 2800 MW	758	715	678	973	471	1,102	331	690	747	<b>722</b>
1255, 2400 MW	748	578	699	982	495	1,087	332	704	641	<b>701</b>
1220, 2800 MW	656	656	640	887	402	943	312	629	398	<b>618</b>
1220, 2400 MW	667	534	650	889	404	919	326	637	435	<b>613</b>
1220, 2000 MW	635	431	614	848	389	874	286	601	435	<b>575</b>

Note: The colour coding is used to highlight relative PV of TSC and NPV within each sensitivity (column) not across all cases: red = lowest, yellow = middle, green = highest.

Source: IPA analysis

### ***Recommended Rogun Design Option***

Based on the results of the technical and economic analysis, the Consortium recommends that the highest dam height alternative (1290 m.a.s.l.) should be taken forward for detailed consideration. The choice between capacity options for this specified dam height design is less clear cut, however, based on the analysis undertaken to date.

The regional least-cost expansion plan suggests that the incremental net benefit of adding capacity beyond a particular point is limited. The extra cost of installing the highest capacity level is not fully compensated since the total annual generation from the Project is primarily determined by dam height (and hence reservoir size) rather than by installed capacity, and the benefit of additional peak capacity is limited by interconnector constraints and the level of achievable prices in Tajikistan and Pakistan (as the principle export market for Tajikistan).

However, maintaining the option of expanding installed capacity at a later stage by leaving one unit pit empty could be a viable option, for example, if demand grows more strongly than forecast. Alternatively, an additional unit could bring more flexibility in the generating system by allowing standby periods for maintenance without the loss of overall annual energy generation. The incremental cost would be recovered by the avoided loss of generation during maintenance. It is recommended that these potential options be examined in detail in the next phase of the studies.

At this stage since the 3,200 MW intermediate installed capacity option shows both the highest overall TSC saving and economic NPV, it has been agreed that further analysis should be undertaken on this recommended design option.

***Reference case least-cost expansion plan:*** Capacity development in Tajikistan for this option, shown in Figure 65, relies mainly on Rogun in the early years, with both ROR and Dam Hydro being built as peak demand increases above 7 GW from 2039 onwards.

**Figure 65: Tajikistan capacity mix by technology type – Rogun 1290 masl, 3,200 MW**

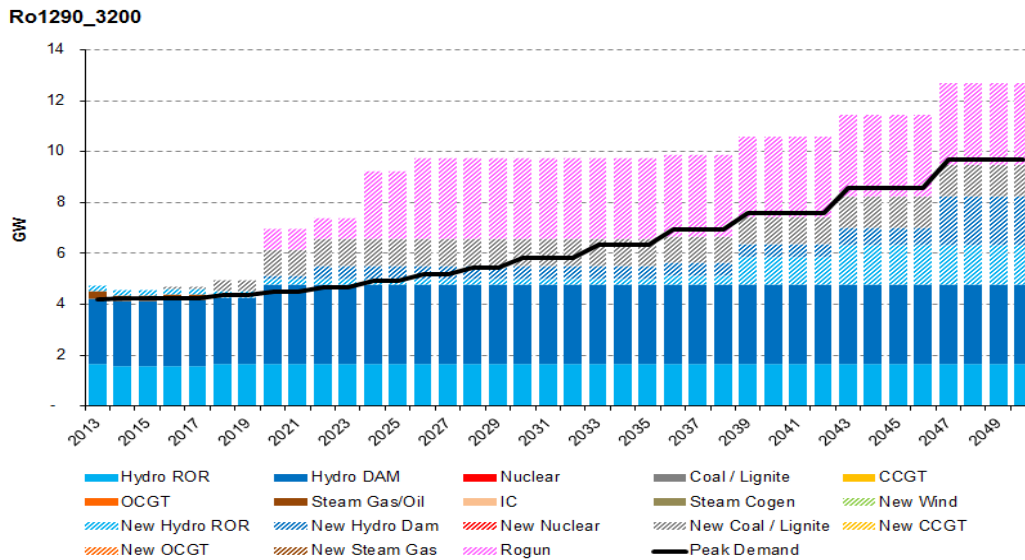

Source: IPA analysis.

As with all the other design options, interconnector expansion to Pakistan beyond the known firm plans is required from 2020 when the Project first starts generating. Net exports grow as the Project comes on line through the 2020s and then gradually decline as domestic demand rises. The quarterly export pattern is similar to the other cases, with imports from Kyrgyzstan during the winter and exports to Pakistan and Afghanistan in the summer, as shown in Figure 66.

**Figure 66: Tajikistan quarterly net exports – Rogun 1290 masl, 3,200 MW**

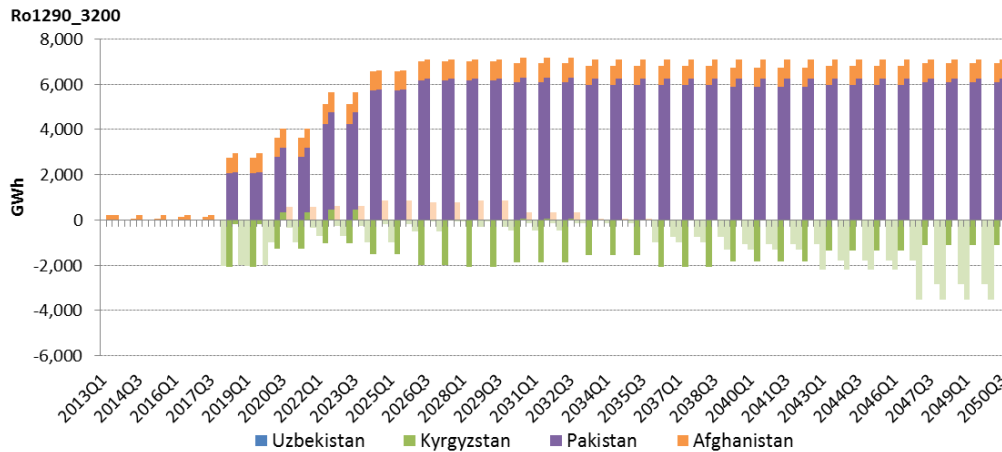

Source: IPA analysis

Once the Project becomes operational and helps meet current levels of unmet demand, electricity costs in Tajikistan fall to around 65USD/MWh. In the later years of the Forecast Horizon when New Build Hydro is required to meet the continually growing demand, they rise to around 100USD/MWh to cover the costs of this investment.

### ***Additional sensitivity and breakeven analysis***

In addition to the eight market-level sensitivities examined as part of the selection of the preferred design option, we also have investigated the robustness of the TSC savings and economic NPV of this design option to a number of other variables, and also determined certain key breakeven values (i.e. the extent to which a particular parameter would have to change from the Reference case to reduce the benefit or value of the Project to zero).

The results of these additional cases on the least-cost expansion plans and consequent TSC savings versus a corresponding No Rogun case are shown in Table 80, and the economic analysis results in Table 81, both together with the original eight sensitivities, and described in more detail below.

**Table 80: Sensitivity of PV of TSC savings for Rogun 1290 masl, 3,200 MW @ 10% discount rate**

Case	PV of TSC savings	Variation to Reference	
	(USD million)	(USD million)	(percentage)
<b>Reference</b>	<b>1,707</b>	-	-
High Demand	1,825	+118	+6.9%
Low Demand	679	-1,028	-60.2%
High Fuel	1,929	+222	+13.0%
Low Fuel	1,238	-469	-27.5%
High TIC	2,531	+824	+48.3%
Low TIC	560	-1,147	-67.2%
High NTC	1,072	-635	-37.2%
Low NTC	1,542	-165	-9.7%
Modified Reference	1,508	-199	-11.6%
Gas generation	775	-933	-54.6%
Gas generation + heating	684	-1,023	-59.9%
Rogun delay:			
2 years	1,770	+63	+3.7%
4 years	1,658	-49	-2.9%
6 years	1,301	-406	-23.8%
Share reimbursement	1,747	+40	+2.3%
Demand growth Ref -55%:			
full savings	389	-1,318	-77.2%
excluding externalities	56	-1,651	-96.7%

Source: IPA analysis.



**Table 81: Sensitivity of economic NPV for Rogun 1290 masl, 3,200 MW @ 10% discount rate**

Case	Economic NPV	Variation to Reference	
	(USD million)	(USD million)	(percentage)
<b>Reference</b>	<b>863</b>	-	-
High Demand	887	+23	+2.7%
Low Demand	765	-98	-11.4%
High Fuel	1,121	+258	+29.8%
Low Fuel	559	-304	-35.2%
High TIC	1,244	+380	+44.0%
Low TIC	420	-444	-51.4%
High NTC	808	-55	-6.4%
Low NTC	819	-45	-5.2%
Rogun delay 2 years	732	-132	-15.2%
Rogun construction extension	657	-207	-24.0%
Rogun TIC:			
-20%	1,417	+553	+64.1%
+20%	310	-553	-64.1%
+31.2%	0	-863	-100.0%
Rogun sale prices:			
domestic tariffs, export -50%	410	-454	-52.5%
only domestic -38.4%	0	-863	-100.0%
only exports -62.5%	0	-863	-100.0%
CO <sub>2</sub> abatement costs	801	-63	-7.3%
No export revenues until Q3 2032	-15	-879	-101.8%

Source: IPA analysis.

1. **Economic Interconnection (Modified Reference):** In order to examine to what extent and how quickly interconnectors are actually required to maximise the export potential of the Project, we considered a specific sensitivity in which the firm CASA-1000 lines are replaced by possible economic new interconnectors from 2018 determined by ECLIPSE.

The results indicate economic interconnector expansion is later than the firm CASA-1000 build. In the No Rogun case, the same total capacity to both Pakistan and Kyrgyzstan is built

by 2033 and 2043 respectively but at a more gradual rate. Similarly, in the Rogun 1290 masl, 3,200 MW option, less interconnection capacity is required to Pakistan and Kyrgyzstan than under the Reference case. This results in a reduction in the PV of the TSC savings by about 200USD million compared to the Reference case, but there is still a very significant benefit. Thus the choice of the preferred Rogun option remains robust even in the absence of firm interconnections from 2017.

- Imported gas supply to Tajikistan:** We examined the potential for gas-fired combined cycle gas turbine (“CCGT”) and/or open cycle gas turbine (“OCGT”) build from 2025, and also for the substitution of electricity for urban space heating. Since Tajikistan has negligible known indigenous gas resources, it was assumed that a dedicated import pipeline from Turkmenistan would be built, and the cost added to the TSC. As a second part of this sensitivity, we also considered the potential for some of the imported gas to be used for urban space heating, replacing corresponding electricity consumption, with appropriate costs of building a distribution network.

In the No Rogun case with gas for electricity generation only, OCGTs are initially built from 2025 partly replacing generic ROR hydro, with CCGTs coming online from 2033. The electricity least-cost expansion results when gas is also used for space heating are similar with slightly smaller capacities deployed reflecting the small reduction in electricity requirements from 2030.

With the larger amount of total gas generation in Tajikistan in the No Rogun case compared to the Rogun case, there is a commensurately higher level of CO<sub>2</sub> emissions – or savings of 2.5-3 million tonnes per year as a result of building Rogun. It should be noted that we have only accounted for Tajik CO<sub>2</sub> emissions, but there are significant emissions savings in the neighbouring countries, particularly Pakistan, because with Rogun exports nearly double thereby reducing fossil fuel use there as well. If these reductions were also included, there would be an additional 700USD million worth of benefit.

The analysis shows that Rogun remains the overall economic least-cost option for the Tajik system even if gas were to become available in the future.

- Delay in starting Rogun construction:** We considered a delay in starting construction of Rogun by 2, 4 or 6 years, maintaining specified implementation schedule thereafter.

Pushing Rogun back by two years results in a slight increase in TSC savings compared to the Reference case through a combination in the delay of expenditure and the generation not necessarily being required earlier to meet forecast demand growth. Further delays though – while still considerably better than the No Rogun case – are worse from a TSC perspective because the benefits from the Project are not realised sufficiently quickly.

Looking at the standalone economic NPV, though, shows a decline against the Reference case, because although costs are reduced in present value terms, the much more significant benefits – particularly in alleviating unserved demand in Tajikistan – are reduced as well.

4. **Share reimbursement costs:** In the event that Rogun is not constructed, in addition to the site decommissioning work required, the Government of Tajikistan would have to repay funds which it raised through a share issue to Tajik investors. The Government estimates that approximately USD60million out of a total amount raised of USD186million has been spent on the works so far at the site, and this amount would thus have to be found from general funds if Rogun did not proceed and should thus be considered as an additional cost in the No Rogun case. This adds about 40USD million to the PV of the TSC savings from Rogun.
5. **Breakeven point for demand growth:** We examined the level of annual growth at which building Rogun would be less beneficial than building Dashtijum by 2033 in the No Rogun case.

As demand growth declines, the advantage of Rogun versus Dashtijum built later is gradually reduced. However, because of the Vakhsh flood protection benefits conferred by Rogun which would otherwise have to be achieved by additional measures downstream, and the upfront site decommissioning costs, the PV of the TSC savings including these externalities doesn't fall to zero even when there is no growth in demand. We have therefore examined the cost savings for the electricity system alone in determining this demand breakeven point.

On this basis, parity is achieved when the annual rate of growth is around 55% below our Reference case (the median of our forecast). Down to around 90% below the median growth, the choice between the two options is very marginal, but then if there were no growth at all, the higher cost of Dashtijum would outweigh the present value benefits of waiting to build – essentially neither large dam is required to meet such low levels of demand growth.

Once the costs of developing alternative flood protection measures for the Vakhsh cascade and decommissioning the Rogun site are factored in, building Rogun remains the preferred alternative irrespective of the level of demand growth.

6. **Wet vs. average year generation:** The economic analysis has so far been based on the average expected electricity generation from the Project calculated from historic average annual rain/snowfall levels. However, this encompasses a range of annual generation levels which will vary from dry to wet years. (Furthermore, because of the constraint of maintaining downstream river flows, it is assumed that there is no storage of water between years as would typically be the case for large dam hydro projects). In wet years, the full summer surplus might not be able to be exported due to transmission constraints. To allow the full potential to be sold, additional interconnection capacity may have to be developed.

The transfer capacity of the interconnector between the Tajikistan and Pakistan is insufficient to allow for all of the extra summer generation in a wet year to be exported. In order to fully realise the export potential and achieve the forecast economic value of the Project, the interconnector would have to be 810MW larger than the expansion calculated by the least-cost modelling. Based on the assumed TIC of new interconnectors of 600USD/kW, this would thus incur an additional cost to Tajikistan of 486USD million, with a present value increase to the TSC of around 100USD million. This is a very small additional percentage on the TSC and much less than the TSC savings conferred by the Project. (It should also be noted that the same principle applies to Dashtijum and other Hydro ROR in the No Rogun case, so that the TSC would be similarly higher in this case than calculated for the average expected generation.)

7. **Extension in Rogun construction timetable:** We examined the effect of an unexpected delay in the construction of Rogun assuming that the full capacity installation was delayed by two years with capital expenditure slowed from 2023 to 2027. Although there is thus a cost savings in PV terms, the lost benefits from the full generation are also more significant, and there is thus a reduction in the NPV of the Project by about a quarter.
8. **Rogun TIC:** The NPV of Rogun will be strongly affected by the actual cost of construction. If costs were to be 31.2% higher than estimated, the NPV would be zero (under the Reference assumptions for market development). It should be noted that a major cause of cost overruns is unexpected geological problems, and in the case of Rogun a major part of the underground works have already been undertaken.

9. **Achieved Rogun sale prices:** While the main economic analysis has been based on the marginal cost of generation for the value of Rogun's generation, in practice the Project revenue will likely be determined by actual electricity tariffs and negotiated contract prices. We have therefore assessed the economic NPV assuming that:

- Domestic sales are priced at 75USD/MWh (real 2012) from 2023 onwards, reflecting an increased tariff level of  $\phi 9/\text{kWh}$ , less estimated transmission and distribution costs of  $\phi 1.5/\text{kWh}$  (with a linear rise to that level from 2014).
- Exports sales are priced at a negotiated compromise position of 50% of the economic marginal cost of those exports.

This specified domestic tariff level is between 5 and 15USD/MWh higher than the forecast marginal cost in 2023-2042, but then 7-8USD/MWh lower. This therefore partly offsets the loss of half the export revenues, such that the total reduction in NPV is only 52.5% from the Reference case.

Domestic prices would have to be almost 40% below the forecast marginal costs throughout the life of the Project to reduce the NPV to zero (with export prices at the Reference marginal costs), on average around 43USD/MWh compared to 70USD/MWh; and export prices would have to be over 60% lower than the respective realised price in each market (on average just under 30USD/MWh against almost 80USD/MWh).

10. **CO<sub>2</sub> abatement benefit versus No Rogun case:** Applying the US Government's social cost of carbon to the change in CO<sub>2</sub> emissions in the modelled Central Asian region as a result of constructing Rogun produces a negative net benefit from Rogun compared to No Rogun as the latter has more installed hydro capacity due to the need to rely on ROR projects. This results in greater summer surpluses and the long post-2050 value to the end of life outweighs the lower early years' savings.
11. **Delay in export revenues:** If export revenues from Pakistan and Afghanistan could not be realised for any reason – for example, due to a prolonged interconnector outage or contractual dispute – the situation would need to persist until the summer of 2032 before the NPV of the Project falls to zero.

## **Conclusions**

This economic analysis demonstrates the economic viability of all the Rogun design options under a range of assumptions. The Project is forecast to provide a probability-weighted system costs savings for Tajikistan of between 1.0 and 1.5USD billion and generate an NPV of 575-835USD million depending on the combination of dam height and installed capacity. This benefit largely derives from the controllable nature of generation from the Project which means that generation can be better matched to demand and also provide considerable levels of exports than the ROR alternatives in Tajikistan.

The higher dam options generally provide greater aggregate benefits than the lower ones due to the greater volumes of generation. Within dam heights, though, installing the highest capacity level is not always optimal, as the majority of the value of a hydroelectric dam is in the volume of water (energy) stored rather than in providing extra peak production.

The 1290 masl 3,200 MW design option exhibits both the highest overall TSC saving and economic NPV, and its economics are robust to a wide range of different outcomes. It is recommended that this dam height option be taken forward for detailed consideration and that additional analysis be undertaken to optimise the installed generation capacity

## CHAPTER 5.2: FINANCIAL ANALYSIS

### *Introduction*

The financial analysis of the Project (the “Financial Analysis”) presented in this chapter is undertaken on the 1290 masl, 3,200 MW Rogun design option only, and all mention of the Project herein refer to this option.

The Report summarises the assumptions, approach, and results of our Financial Analysis under the central case (the “Base Case”) from 2013 to 2050 (the “Forecast Horizon”). This Base Case adopts many of the planning assumptions used for the central case of the Economic Analysis (“Reference Case”). We also consider a sensitivity in which construction cost overruns increase the capital expenditure (“capex”) requirement for the Project by 20% (“Higher Capex Case”). At this stage, this analysis aims to identify a high-level range of funding possibilities for the Project, subject to assumed costs for various potential sources.

In contrast to the Economic Analysis, all monetary figures presented in the Report are stated in nominal price terms and United States Dollars (“USD”), unless otherwise stated. Input costs and revenues from the Economic Analysis have been inflated from real 2013 price terms at the annual USD inflation rate forecast by the International Monetary Fund (“IMF”) World Economic Outlook (“WEO”) to 2018 and a long-term assumption of 2% per annum thereafter.

### *Project assumptions*

The breakdown of capex was provided by Coyne et Bellier and ELC. Note that the costs of domestic transmission reinforcement and interconnector build are not taken into account in the capex figure. As such, additional capital funding beyond that estimated in our Financial Analysis would be required to realise the value of the Project.

There are certain aspects of the Project which must be fully completed for safety reasons once construction has commenced and, hence, for which it is crucial to ensure that full financing is available at the start. For this purpose, we have split the capex into “safety critical”, “electromechanical”, and “other” categories, as shown in Figure 67 below.

**Figure 67: Project cost breakdown over the Forecast Horizon**

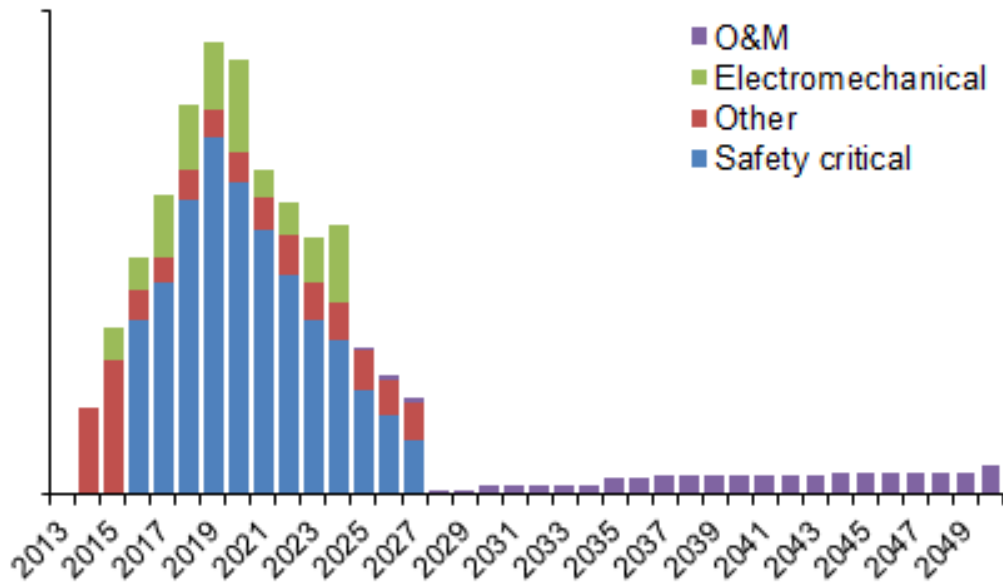

Source: Coyne et Bellier, ELC, IPA assumptions.

Project revenues are based on electricity prices and generation of electricity for Tajikistan and the export markets. Electricity generation assumptions are taken from the results for the Reference Case in our Economic Analysis. Electricity prices in Tajikistan are based on the expected electricity tariff in the country, whilst electricity prices in the export markets are assumed to be half the electricity prices derived under the Reference Case of our Economic Analysis.

### **Financing assumptions**

The following four financing structures have been examined, in all cases supplemented by net operating revenues from early generation during the construction period:

12. **Full Self-Financing (“FS1”)**: The capital requirements will be fully funded through equity from the Government of Tajikistan (“GoT”).
13. **Preferential Loan (“FS2”)**: This structure envisages a friendly foreign government with a strategic interest in the Project prepared to offer preferential terms for a loan. The financing structure reflects the maximum amount of preferential loan, subject to the constraint that at least 10% of the total external funding is equity from the GoT, which can be supported by the



Project whilst maintaining a positive cash flow and a Debt Service Coverage Ratio (“DSCR”) above 1.25 throughout the Forecast Horizon.

14. **Multilateral and Commercial Loan (“FS3”)**: The third option considers debt from both multilateral agencies (international financing institutions) and commercial lenders. The financing structure reflects the maximum amount of multilateral and commercial loans, subject to the constraint that the level of debt be no more than 90% of total external funding, which can be supported by the Project whilst maintaining a positive cash flow and a DSCR above 1.25 throughout the Forecast Horizon. We have assumed that the commercial loan may only be drawn down to meet the cost of the electromechanical equipment for the Project and cannot be used for any other elements of the capex.
15. **Bond (“FS4”)**: This structure examines the potential for the issuance of a hypothecated bond. In order to provide security as to the funding of the repayment, a dedicated cash fund (or bond set-aside) is retained. The financing structure reflects the minimum amount of equity funding required in combination with a bond to maintain a positive cash flow throughout the Forecast Horizon.

In addition to the revenues earned directly by the Project from early generation, other net electricity export revenues will secure foreign currency for the Government which could be used towards the financing.

The assumptions regarding the sources of funding are summarised in Table 82 below.

<b>Table 82: Sources of funding assumptions</b>					
<b>Item</b>	<b>Units</b>	<b>Source of funding</b>			
		<b>Bond</b>	<b>Preferential loan</b>	<b>Multilateral loan</b>	<b>Commercial loan</b>
<b>Cost of funding</b>					
LIBOR <sup>1</sup>	%/year	-	3.30%	3.30%	3.30%
Premium	%/year	-	1.70%	1.30%	9.00%
Coupon / interest rate	%/year	10%	5.00%	4.60%	12.30%
Upfront fee	%	-	0.50%	0.25%	1.50%
Commitment fee	%/year	-	0.50%	0.25%	1.50%
<b>Drawdown and repayment schedule</b>					

**Table 82: Sources of funding assumptions**

Item	Units	Source of funding			
		2020	2015	2015	2020
First year available	-	2020	2015	2015	2020
Bond duration / loan tenor	years	25	25	20	15
First year of coupon/ interest repayment	-	2020	2025	2025	2025
Maturity	-	2044	2039	2034	2034

<sup>1</sup>: London Interbank Offered Rate (“LIBOR”).

Source: Client and IPA assumptions.

## Results

The four financing structures and their associated Financial Internal Rates of Return (“FIRR”), expressed in post-tax nominal terms, are summarised in Table 83 below. Note that these financing structures have been considered to help identify the funding requirements given the constraints that would need to be considered in the following phases of any financial analysis.

**Table 83: Total returns by financing structure**

Item	Units	FS1	FS2	FS3	FS4
<b>Project</b>					
FIRR	%	11.88%	12.07%	12.05%	12.17%
<b>Payback</b>					
Nominal	years	18	18	18	18
Discounted	years	30	29	29	28
<b>Equity</b>					
FIRR	%	10.97%	22.25%	22.52%	11.18%
<b>Payback</b>					
Nominal	years	19	16	16	19
Discounted	years	36	17	18	36

Source: IPA analysis.

Our results under FS2 and FS3 suggest that the Project can support a ratio of debt to total external funding of close to 90%.

Under the Base Case, the Project achieves a FIRR of around 12%, above an indicative 10% Weighted Average Cost of Capital (“WACC”), for all financing structures. The Equity FIRR is higher under FS2 and FS3 as the levels of equity required to finance the Project are much lower than under FS1 and FS4. With increased capex, higher levels of equity are needed under all four financing structures, reducing the FIRRs and increasing the payback period. The Equity FIRR falls marginally below the 10% indicative WACC under FS1 and FS4 in this instance.

In the next stage of the Project’s appraisal, when more detailed analysis is undertaken on the design, specific discussions would need to be held with potential funders in order to gauge the precise level of external financing which could be available for its construction, and the costs thereof.

## **VOLUME 6: RISK ANALYSIS**

## 1 INTRODUCTION

The Risk Analysis represents an important element of the Project Assessment as it summarizes and qualifies the main topics that may affect the project technical feasibility, attractiveness and sustainability, detected during the development of the studies. This is of considerable importance for a technically challenging project such as Rogun. It is indeed to be highlighted, as described in the previous chapters, that the three proposed alternatives have specific technical challenges that shall be carefully assessed. In particular, it is to be reminded that the highest dam alternative would be a world record, making this risk analysis all the more important.

Three main phases are to be considered when developing a Risk Analysis: identification, evaluation and management. The risk identification phase detects, describes and qualifies the causes as well as the potential effects. The risk evaluation phase quantifies these risks and compares these to the tolerable or acceptable values that a person, a community or a population is ready to accept in view of the benefit they are expecting from the concerned goods or activities. And finally, the risk management phase is the one in which remedial or mitigation measures are proposed in order to reduce (as far as possible) the detected risks to an acceptable value and then implements these measures and ensures their successful follow-up.

It is therefore recalled here that the main purpose of this analysis is to identify the mitigation measures which need to be implemented in order to reduce the level of risk. The residual risk rating enclosed in this analysis is therefore, by definition, the result of successful implementation of these mitigation measures.

This document is meant to evolve during the project development and be updated in order to reflect the actual implementation of these measures during the next phases of the studies and project implementation.

## 2 TERMINOLOGY AND METHODOLOGY

Risk is considered here as a situation involving exposure to danger. The level of exposure is defined as the likelihood of occurrence (non-dimensional) of an unwanted event (cause) and the level or degree of danger is measured as the amount of damage if that unwanted event occurs (effect or impact evaluated in monetary terms). Risk is then measured as the product of the level of exposure (probability of occurrence) times the level of danger (amount of damage). Its unit is

therefore the same as the level of danger and shall therefore be labeled as insignificant, minor, moderate, major or extreme.

### **3 RISK IDENTIFICATION**

In order to normalize the analysis, a classification of the different categories of causes and effects is performed.

Causes are classified in four different “families” of sources of potential unwanted events: natural causes, technical causes, economic-financial and socio-political causes. In a similar manner, the components of the project likely to be impacted are classified in six different systems: dam system, reservoir system, construction and access systems, flood management system and power system.

### **4 RISK EVALUATION**

Risk evaluation is made by estimation of both the likelihood of occurrence of the unwanted event and the amount of damage, should the unwanted event occur.

The gradation adopted for the risk estimation is deduced from the classifications of likelihood and impact. By combining (multiplying) the probability of occurrence with the cost of impacts, the risk is estimated. The likelihood or probability of occurrence being a non-dimensional magnitude, risk takes the same units as the impact that it may produce. Risk is then expressed in MUS\$.

		CONSEQUENCE (Amount in M.USD)				
LIKELIHOOD		Insignificant	Minor	Moderate	Major	Extreme
		1	10	100	1 000	
Almost certain	1 :1					
Likely	9 :10					
Moderate	1 :10					
Unlikely	1 :100					
Rare	1 :1 000					
Extremely rare	1 :10 000					

Table 84: Risk Estimation Table [MUS\$]

In order to organize and present data and information relative to this risk assessment, “risk sheets” have been implemented (to be found in appendix of Volume 6).

The tables below show the number of cases evaluated at each level of risk and how their severity was reduced with the relevant mitigation measures.

	BEFORE MITIGATION	AFTER MITIGATION
	6	0
	6	0
	11	6
	2	17
	1	3
<b>Total</b>	<b>26</b>	<b>26</b>

Table 85: Risk Distribution by Severity Level Before and After Mitigation Measures

	Extreme	Major	Moderate	Minor	Cause	Effect
A	4A	●			Sediments	Flood Management
	7	●			Salt Wedge	Dam Safety
	17	●			Rock Quality	Cavern Safety
	20	●			Design Head	Flood Management
	11	●			Creep in Faults	Flood Management
	15B	●			Seism.Displ.	Flood Management
B	18	●			Construction DTs	Flood Management
	2	●			Floods	Dam Safety
	4B	●			Sediments	Power and Energy
	12	●			Mudflows	Flood Management
	16	●			Dam Materials	Dam Safety
	8A	●			Reservoir Rim	Dam Safety
C			6	●	Earthquakes	Dam Safety
			14	●	Landslides	Construction Safety
			10A	●	Landslides	Dam Safety
			13	●	Reservoir Leakage	Power and Energy
			21	●	Constr. Schedule	Overcosts
			15C	●	Seism.Displ.	Power and Energy
			19	●	Design, Data	Overcosts, over delays
			1	●	Floods	Dam Safety
			3	●	GLOFs	Dam Safety
			8B	●	Salt-Gypsum	Structural Collapses
		10B	●	Landslides	Flood Management	
<p>Before: 6 6 11 =23</p> <p>After : 6 17 =23</p>						

**Figure 68: Level of Risk Before and After Mitigation Measures** for risks having an original level of risk equal or higher than moderate



The following table gives a summary of risk sheets, detailing the cause, the systems impacted and the risk evaluation before and after mitigation measures. The numbering system from the original study has been kept.

Sheet n°	Cause			System(s)	Risk evaluation	
	Level 1	Level 2	Level 3		Before mitigation	After mitigation
1	Natural	Hydrology	Rare floods	Dam system	Yellow	Green
2	Natural	Hydrology	Construction floods	Dam system	Red	Green
3	Natural	Hydrology	GLOFs	Dam system	Yellow	Green
4A	Natural	Hydrology	Sediments	Flood management system	Red	Yellow
4B	Natural	Hydrology	Sediments	Power & Energy system	Orange	Green
5	Natural	Hydrology	Water availability	Power & Energy system	Green	Dark Green
6	Natural	Seismic	Earthquakes	Dam system / Flood management system	Yellow	Dark Green
7	Natural	Geological / Geotechnical / Geomechanical	Salt dissolution in dam foundation	Dam system / Flood management system	Red	Yellow
8A	Natural	Geology / Geotechnics / Geomechanics	Reservoir rim slope instability	Dam System / Access	Orange	Green
8B	Natural	Geological / Geotechnical / Geomechanical	Karst in the reservoir (close to Rogun city)	Reservoir system	Yellow	Green
9	Natural	Geology / Geotechnics / Geomechanics	Salt intrusion in RB	Dam system	Green	Dark Green

Sheet n°	Cause			System(s)	Risk evaluation	
	Level 1	Level 2	Level 3		Before mitigation	After mitigation
10A	Natural	Geology / Geotechnics / Geomechanics	RB-DS important instability	Dam system / Flood management system		
10B	Natural	Geology / Geotechnics / Geomechanics	RB-DS important instability	Dam system		
11	Natural	Geology / Geotechnics / Geomechanics	Long-term creeping of faults	Dam system / Flood management system / Power & Energy system		
12	Natural	Geology / Geotechnics / Geomechanics	Mudflows from Obishur R. and other streams	Access / Dam system / Flood management system / Power & Energy system		
13	Natural	Geology / Geotechnics / Geomechanics	Leakage from reservoir	Reservoir system / Power & Energy system		
14	Natural	Geology / Geotechnics / Geomechanics	Dam excavations slope instabilities	Dam system		
15A	Natural	Geology / Geotechnics / Geomechanics	Co-seismic displacements	Dam system		
15B	Natural	Geology / Geotechnics / Geomechanics	Co-seismic displacements	Flood management system		
15C	Natural	Geology / Geotechnics / Geomechanics	Co-seismic displacements	Power & Energy system		
16	Natural	Geology / Geotechnics / Geomechanics	Dam materials: Inappropriate survey, inadequate materials	Dam system		
17	Natural	Geology / Geotechnics / Geomechanics	Structures- Caverns: rock excavation	Power & Energy system		

Sheet n°	Cause			System(s)	Risk evaluation	
	Level 1	Level 2	Level 3		Before mitigation	After mitigation
18	Technical	Maintenance & Operation	Diversion/Tailrace tunnels: construction quality	Flood management system / Power & Energy system		
19	Technical	Design	Design studies	Dam system/Flood management system		
20	Technical	Design	Maximum head in tunnels	Dam system		
21	Technical	Construction	Construction schedule	Dam system/Flood management system		

**Table 86 : Risk sheet summary**

## 5 CONCLUSIONS AND RECOMMENDATIONS

The present chapter described risk identification procedures, methods and ranges used for risk evaluation as well as the proposed mitigation measures. In addition, the residual risks following the implementation of the proposed mitigation measures have been assessed. Dedicated Risk Sheets have been elaborated for each of the 26 cases of risk considered in the study.

Only six cases remain at a level of “moderate” risk after the proposed mitigation measures were applied; none remains at a higher level of risk. The quotation of the remaining six cases could have been brought down by one level, but it was strategically decided to keep them at the level of “moderate” so that they would act as a reminder of required actions in the next phase of studies. The remaining cases call to mind the fact that further investigations and design improvements are to be developed during the next stages of the project, once an appropriate project alternative is selected.

The sources of the six remaining risks are five natural causes (sediments, seismicity, active fault with salt in-filling, locally poor quality of rock, creeping of faults) and one design cause (a hydraulic head that is too high, upon gates in hydro-tunnels) which is closely related to the height of the proposed dam. These six risk cases are then to be considered as representative of the complexity and difficulty of the project.

On the basis of the conclusions drawn from the present technical risk analysis, the Rogun Hydropower Project implementing agency may now continue its development with the next stage of the studies – the further specific analyses that have been recommended here and the detailed design of the selected alternative.

Further investigations and design refinements will have to be performed over the next stages of the project, once the dam height alternative is chosen in order to detail further the mitigations measures to be implemented. Priority shall be given to the six residual risks identified as moderate, ensuring proper detailed design of the mitigation measures, correlated monitoring of their effectiveness and contingency plan in case of reduced efficiency of the mitigation measures implemented.

Hereafter are presented the Risk Sheets corresponding to the six risks with a moderate level of risk after implementation of the corresponding mitigation measures.

GENERAL INFORMATION		Rogun HPP		TEAS Consortium - Phase II - Risk assessment		07/08/2014																											
		Sheet n°		4A		Risk ID																											
						Sediments																											
						Flood management system																											
						Risk evaluation																											
		Before mitigation		After mitigation																													
IDENTIFICATION		<table border="1"> <thead> <tr> <th colspan="2">CAUSE</th> </tr> </thead> <tbody> <tr> <td>Level 1</td> <td>Natural</td> </tr> <tr> <td>Level 2</td> <td>Hydrology</td> </tr> <tr> <td>Level 3</td> <td>Sediments</td> </tr> </tbody> </table>		CAUSE		Level 1	Natural	Level 2	Hydrology	Level 3	Sediments	<table border="1"> <thead> <tr> <th colspan="3">IMPACT</th> </tr> <tr> <th></th> <th>SYSTEM (S)</th> <th>COMPONENT (S)</th> </tr> </thead> <tbody> <tr> <td>1.</td> <td>Flood management system</td> <td>Temporary low tunnels</td> </tr> <tr> <td>2.</td> <td>Flood management system</td> <td>Temporary high tunnels</td> </tr> <tr> <td>3.</td> <td>Flood management system</td> <td>Permanent tunnels</td> </tr> <tr> <td>4.</td> <td>Flood management system</td> <td>Surface Spillways</td> </tr> </tbody> </table>		IMPACT				SYSTEM (S)	COMPONENT (S)	1.	Flood management system	Temporary low tunnels	2.	Flood management system	Temporary high tunnels	3.	Flood management system	Permanent tunnels	4.	Flood management system	Surface Spillways		
CAUSE																																	
Level 1	Natural																																
Level 2	Hydrology																																
Level 3	Sediments																																
IMPACT																																	
	SYSTEM (S)	COMPONENT (S)																															
1.	Flood management system	Temporary low tunnels																															
2.	Flood management system	Temporary high tunnels																															
3.	Flood management system	Permanent tunnels																															
4.	Flood management system	Surface Spillways																															
DESCRIPTION (before mitigation)		<table border="1"> <thead> <tr> <th>CAUSE (S)</th> <th>Likelihood</th> </tr> </thead> <tbody> <tr> <td>1. Sediment through temporary low tunnels.</td> <td>Almost certain</td> </tr> <tr> <td>2. Sediment through temporary high tunnels.</td> <td>Rare</td> </tr> <tr> <td>3. Sediment through permanent tunnels.</td> <td>Almost certain</td> </tr> <tr> <td>4. Sediment through permanent surface spillways.</td> <td>Almost certain</td> </tr> </tbody> </table>		CAUSE (S)	Likelihood	1. Sediment through temporary low tunnels.	Almost certain	2. Sediment through temporary high tunnels.	Rare	3. Sediment through permanent tunnels.	Almost certain	4. Sediment through permanent surface spillways.	Almost certain	<table border="1"> <thead> <tr> <th>IMPACT (S)</th> <th>Evaluation</th> </tr> </thead> <tbody> <tr> <td>1. Abrasion damages of temporary low tunnels.</td> <td>Extreme</td> </tr> <tr> <td>2. Abrasion damages of temporary high tunnels.</td> <td>Major</td> </tr> <tr> <td>3. Abrasion damages of permanent tunnels.</td> <td>Extreme</td> </tr> <tr> <td>4. Abrasion damages of surface spillways.</td> <td>Extreme</td> </tr> </tbody> </table>		IMPACT (S)	Evaluation	1. Abrasion damages of temporary low tunnels.	Extreme	2. Abrasion damages of temporary high tunnels.	Major	3. Abrasion damages of permanent tunnels.	Extreme	4. Abrasion damages of surface spillways.	Extreme	<table border="1"> <thead> <tr> <th>Risk</th> </tr> </thead> <tbody> <tr> <td style="background-color: red;"></td> </tr> <tr> <td style="background-color: green;"></td> </tr> <tr> <td style="background-color: red;"></td> </tr> <tr> <td style="background-color: red;"></td> </tr> <tr> <td style="background-color: red;"></td> </tr> </tbody> </table>		Risk					
CAUSE (S)	Likelihood																																
1. Sediment through temporary low tunnels.	Almost certain																																
2. Sediment through temporary high tunnels.	Rare																																
3. Sediment through permanent tunnels.	Almost certain																																
4. Sediment through permanent surface spillways.	Almost certain																																
IMPACT (S)	Evaluation																																
1. Abrasion damages of temporary low tunnels.	Extreme																																
2. Abrasion damages of temporary high tunnels.	Major																																
3. Abrasion damages of permanent tunnels.	Extreme																																
4. Abrasion damages of surface spillways.	Extreme																																
Risk																																	
		<table border="1"> <thead> <tr> <th colspan="2">Comments</th> </tr> </thead> <tbody> <tr> <td colspan="2">a. No trap efficiency of the early stage low reservoir, therefore abrasive materials through the low tunnels. b. In the short time available, no sediments will have reached the high tunnels.</td> </tr> </tbody> </table>		Comments		a. No trap efficiency of the early stage low reservoir, therefore abrasive materials through the low tunnels. b. In the short time available, no sediments will have reached the high tunnels.		<table border="1"> <thead> <tr> <th colspan="2">Comments</th> </tr> </thead> <tbody> <tr> <td colspan="2"></td> </tr> </tbody> </table>		Comments				ADOPTED																			
Comments																																	
a. No trap efficiency of the early stage low reservoir, therefore abrasive materials through the low tunnels. b. In the short time available, no sediments will have reached the high tunnels.																																	
Comments																																	
MITIGATION MEASURES		<table border="1"> <thead> <tr> <th colspan="2">Recommended mitigation measures</th> </tr> </thead> <tbody> <tr> <td colspan="2">1. Proper design. Low velocities. Allowing inspection and maintenance works. 3. Do not rely on pressure tunnels for long term flood management. 4. Redundancy of the spillway facilities. 1 - 2 - 3 - 4. Monitoring flow turbidity and closure of tunnels when abrasive materials reach the intakes. / Recurrent preventive maintenance.</td> </tr> </tbody> </table>		Recommended mitigation measures		1. Proper design. Low velocities. Allowing inspection and maintenance works. 3. Do not rely on pressure tunnels for long term flood management. 4. Redundancy of the spillway facilities. 1 - 2 - 3 - 4. Monitoring flow turbidity and closure of tunnels when abrasive materials reach the intakes. / Recurrent preventive maintenance.		<table border="1"> <thead> <tr> <th colspan="2">Recommended mitigation measures</th> </tr> </thead> <tbody> <tr> <td colspan="2">1 - 2. End of life design considerations. 1 - 2 - 3. Closure of tunnels when abrasive materials reach the intakes. 1 - 2 - 3 - 4. Repair works after each flood season.</td> </tr> </tbody> </table>		Recommended mitigation measures		1 - 2. End of life design considerations. 1 - 2 - 3. Closure of tunnels when abrasive materials reach the intakes. 1 - 2 - 3 - 4. Repair works after each flood season.																					
Recommended mitigation measures																																	
1. Proper design. Low velocities. Allowing inspection and maintenance works. 3. Do not rely on pressure tunnels for long term flood management. 4. Redundancy of the spillway facilities. 1 - 2 - 3 - 4. Monitoring flow turbidity and closure of tunnels when abrasive materials reach the intakes. / Recurrent preventive maintenance.																																	
Recommended mitigation measures																																	
1 - 2. End of life design considerations. 1 - 2 - 3. Closure of tunnels when abrasive materials reach the intakes. 1 - 2 - 3 - 4. Repair works after each flood season.																																	
		<table border="1"> <thead> <tr> <th colspan="2">Comments</th> </tr> </thead> <tbody> <tr> <td colspan="2"></td> </tr> </tbody> </table>		Comments				<table border="1"> <thead> <tr> <th colspan="2">Comments</th> </tr> </thead> <tbody> <tr> <td colspan="2"></td> </tr> </tbody> </table>		Comments																							
Comments																																	
Comments																																	
RESIDUAL RISK (after mitigation)		<table border="1"> <thead> <tr> <th>CAUSE (S)</th> <th>Likelihood</th> </tr> </thead> <tbody> <tr> <td>1. Sediment through temporary low tunnels.</td> <td>Likely</td> </tr> <tr> <td>2. Sediment through temporary high tunnels.</td> <td>Rare</td> </tr> <tr> <td>3. Sediment through permanent tunnels.</td> <td>Extremely rare</td> </tr> <tr> <td>4. Sediment through permanent surface spillways.</td> <td>Almost certain</td> </tr> </tbody> </table>		CAUSE (S)	Likelihood	1. Sediment through temporary low tunnels.	Likely	2. Sediment through temporary high tunnels.	Rare	3. Sediment through permanent tunnels.	Extremely rare	4. Sediment through permanent surface spillways.	Almost certain	<table border="1"> <thead> <tr> <th>IMPACT (S)</th> <th>Evaluation</th> </tr> </thead> <tbody> <tr> <td>1. Abrasion damages of temporary low tunnels.</td> <td>Moderate</td> </tr> <tr> <td>2. Abrasion damages of temporary high tunnels.</td> <td>Moderate</td> </tr> <tr> <td>3. Abrasion damages of permanent tunnels.</td> <td>Insignificant</td> </tr> <tr> <td>4. Abrasion damages of surface spillways.</td> <td>Moderate</td> </tr> </tbody> </table>		IMPACT (S)	Evaluation	1. Abrasion damages of temporary low tunnels.	Moderate	2. Abrasion damages of temporary high tunnels.	Moderate	3. Abrasion damages of permanent tunnels.	Insignificant	4. Abrasion damages of surface spillways.	Moderate	<table border="1"> <thead> <tr> <th>Risk</th> </tr> </thead> <tbody> <tr> <td style="background-color: yellow;"></td> </tr> <tr> <td style="background-color: green;"></td> </tr> <tr> <td style="background-color: green;"></td> </tr> <tr> <td style="background-color: yellow;"></td> </tr> <tr> <td style="background-color: yellow;"></td> </tr> </tbody> </table>		Risk					
CAUSE (S)	Likelihood																																
1. Sediment through temporary low tunnels.	Likely																																
2. Sediment through temporary high tunnels.	Rare																																
3. Sediment through permanent tunnels.	Extremely rare																																
4. Sediment through permanent surface spillways.	Almost certain																																
IMPACT (S)	Evaluation																																
1. Abrasion damages of temporary low tunnels.	Moderate																																
2. Abrasion damages of temporary high tunnels.	Moderate																																
3. Abrasion damages of permanent tunnels.	Insignificant																																
4. Abrasion damages of surface spillways.	Moderate																																
Risk																																	
		<table border="1"> <thead> <tr> <th colspan="2">Comments</th> </tr> </thead> <tbody> <tr> <td colspan="2"></td> </tr> </tbody> </table>		Comments				<table border="1"> <thead> <tr> <th colspan="2">Comments</th> </tr> </thead> <tbody> <tr> <td colspan="2"></td> </tr> </tbody> </table>		Comments				ADOPTED																			
Comments																																	
Comments																																	

GENERAL INFORMATION		Rogun HPP		TEAS Consortium - Phase II - Risk assessment		07/08/2014	
GENERAL INFORMATION					Sheet n°		7
					Risk ID		Salt dissolution in dam foundation Dam system / Flood management system
					Risk evaluation		
					Before mitigation		After mitigation
IDENTIFICATION	CAUSE			IMPACT			
	Level 1	Natural		SYSTEM (S)	COMPONENT (S)		
DESCRIPTION (before mitigation)	Level 2	Geological / Geotechnical / Geomechanical		1.	Dam system		Main dam
	Level 3	Salt dissolution in dam foundation		2.	Power & Energy system		Intake
MITIGATION MEASURES	CAUSE (S)		Likelihood	IMPACT (S)		Evaluation	
	1. Leaching of salt wedge within Ionakhsh fault.		Almost certain	1. Deformation of foundation and dam body.		Extreme	
RESIDUAL RISK (after mitigation)	2. Leaching of salt within the left bank.		Moderate	2. Creeping or sliding of power intake foundations.		Major	
	3. Leaching of salt within the left bank.		Moderate	3. Damages to portals of diversion tunnels 1, 2. Damage to diversion tunnel 3.		Major	
4. Leaching of salt within the left bank.		Moderate	4. Potential damage to mid-level outlet or high-level outlets.		Extreme		
Comments				Comments			
a. Excessive leaching of the salt wedge of Ionakhsh Fault: the top of the salt wedge get lower.				a. If the rate of leaching is larger than expected, the deformation of the stage 1 dam body and foundation may lead, in the extreme case, to overtopping. In case of the main dam, it may affect watertightness components of the dam (clay core), and may finally lead to overtopping.			
b. Salt elevation and arrangement within the right bank is not known, possible dissolution after impounding of such salt is deemed not impossible.				b. Dissolution of the salt wedge at the foot of the slope, which constitutes the intake foundation may lead to unacceptable creeping even sliding of the intake foundation (major consequences, since flood management still assumed to be in working conditions).			
				c. Rapid leaching of salt may lead to unacceptable settlements of portal foundations, and collapse due to scouring.			
				d. Damages to the mid-level outlet and other tunnels may lead to deformation of tunnel lining, having catastrophic consequences if unnoticed and leading to tunnel collapse after scouring by water under high velocity.			
Recommended mitigation measures				Recommended mitigation measures			
1 -2-3-4. Implementation of hydraulic barrier				1 -2-3-4. Reduction of gradient above top of salt wedge			
/ Grouting of the top area of the salt wedge (<1 LU)				/ Reduction of water circulation above the top of salt wedge			
/ Monitoring of salt wedge rising rate				/ Calibration of leaching model for better assessment of leaching			
/ General monitoring (salt content, gravimetry, deformations, etc.)				/ Survey of eventual leaching progression			
/ Grouting of Gulizindan Fault end and right bank investigation.				/ Check potential leakages through right bank or Gulizindan Fault.			
Comments				Comments			
a. Hydraulic barrier downstream the top of the salt wedge is to be provided, with pressure being that of the reservoir to balance the gradient.				a. Both hydraulic barriers and grouting of the top area of the salt wedge are judged necessary from the modelling of salt leaching, at least for stage 1 dam.			
b. The grouting of the top area of the salt wedge shall be efficiently performed and actually reach less than 1 LU in hydraulic conductivity				b. The rising rate of the salt wedge within the Ionakhsh Fault is a key input parameter for salt leaching modelling and needs to be verified as soon as possible.			
c. Monitoring of the rising rate of the salt wedge is to be performed, as an essential input data for modelling of the leaching process.				c. All other monitoring listed in RP38 report aims at following the progress of the potential dissolution of the salt wedge, by measuring settlements, water salinity variations and regular microgravimetric investigations.			
d. General monitoring as per Phase 0 report RP38 is to be implemented (measurements of settlements, salinity of water, investigation of the possible evolution in voids by microgravimetry, etc.)				d. Investigations of the right bank should allow to know if specific mitigation measures are still required.			
e. Detailed geological investigations to check the exact elevation of salt within the downstream right bank are to be performed.							
CAUSE (S)		Likelihood		IMPACT (S)		Evaluation	
1. Leaching of salt wedge within Ionakhsh fault.		Likely		1. Deformation of foundation and dam body (stage 1, main dam).		Moderate	
2. Leaching of salt within the right bank.		Unlikely		2. Creeping or sliding of power intake foundations.		Moderate	
3. Leaching of salt within the right bank.		Unlikely		3. Damages to portals of diversion tunnels 1, 2 . Damage to tunnel 3.		Moderate	
4. Leaching of salt within the right bank.		Unlikely		4. Potential damage to mid-level outlet or high-level outlets.		Moderate	
Comments				Comments			
a. The likelihood of reduction of efficiency of the hydraulic barrier will straightly depend upon its correct desing and implementation during construction. It makes reference to excessive leaching.				a. The hydraulic barrier is mostly necessary for the stage 1 dam.			
b. The loss of efficiency at long term of the grouting is unavoidable, due to the progressive creepinf of the Ionakhsh Fault, and may be completely inefficient in case of co-sismic movement along this fault.				b. It is verified that loss of efficiency of grouting down to 0.1LU does not have any impact, according to salt leaching model; like hydraulic barrier, it is not really necessary for the main dam.			
c. Monitoring devices shall be selected and installed with care, in order to guarantee long-term service, within salty water.				c. Having the monitoring means failing to work, especially for stage 1 dam results in that any leaching will occur unnoticed, and damages can appear suddenly; risk is major for the stage 1 dam.			
				d. It is supposed for the residual risk that dedicated investigations were carried out, such as the conditions of right bank are better known than today.			

GENERAL INFORMATION		Rogun HPP		TEAS Consortium - Phase II - Risk assessment		07/08/2014																									
		Sheet n°		11		Risk ID																									
		Risk ID		Long-term creeping of faults		Dam system / Flood management system / Power & Energy system																									
		Risk evaluation		Before mitigation		After mitigation																									
IDENTIFICATION		<table border="1"> <thead> <tr> <th colspan="2">CAUSE</th> </tr> </thead> <tbody> <tr> <td>Level 1</td> <td>Natural</td> </tr> <tr> <td>Level 2</td> <td>Geology / Geotechnics / Geomechanics</td> </tr> <tr> <td>Level 3</td> <td>Long-term creeping of faults</td> </tr> </tbody> </table>		CAUSE		Level 1	Natural	Level 2	Geology / Geotechnics / Geomechanics	Level 3	Long-term creeping of faults	<table border="1"> <thead> <tr> <th colspan="2">IMPACT</th> </tr> <tr> <th>SYSTEM (S)</th> <th>COMPONENT (S)</th> </tr> </thead> <tbody> <tr> <td>1. Dam system</td> <td>Cofferdam</td> </tr> <tr> <td>2. Dam system</td> <td>Main dam</td> </tr> <tr> <td>2. Flood management system</td> <td>Diversion Tunnels 1,2,3</td> </tr> <tr> <td>2. Flood management system</td> <td>Mid Level tunnels 1,(2)</td> </tr> <tr> <td>3. Power &amp; Energy system</td> <td>Powerhouse</td> </tr> <tr> <td>3. Power &amp; Energy system</td> <td>Penstock</td> </tr> </tbody> </table>		IMPACT		SYSTEM (S)	COMPONENT (S)	1. Dam system	Cofferdam	2. Dam system	Main dam	2. Flood management system	Diversion Tunnels 1,2,3	2. Flood management system	Mid Level tunnels 1,(2)	3. Power & Energy system	Powerhouse	3. Power & Energy system	Penstock		
CAUSE																															
Level 1	Natural																														
Level 2	Geology / Geotechnics / Geomechanics																														
Level 3	Long-term creeping of faults																														
IMPACT																															
SYSTEM (S)	COMPONENT (S)																														
1. Dam system	Cofferdam																														
2. Dam system	Main dam																														
2. Flood management system	Diversion Tunnels 1,2,3																														
2. Flood management system	Mid Level tunnels 1,(2)																														
3. Power & Energy system	Powerhouse																														
3. Power & Energy system	Penstock																														
DESCRIPTION (before mitigation)		<table border="1"> <thead> <tr> <th>CAUSE (S)</th> <th>Likelihood</th> </tr> </thead> <tbody> <tr> <td>1. Creeping movement Ionakhsh / Fault 35.</td> <td>Almost certain</td> </tr> <tr> <td>2. Tilting of block between Ionakhsh Fault and Fault 35.</td> <td>Almost certain</td> </tr> <tr> <td>3. Creeping of Fault 70 or subsidiary faults.</td> <td>Likely</td> </tr> </tbody> </table>		CAUSE (S)	Likelihood	1. Creeping movement Ionakhsh / Fault 35.	Almost certain	2. Tilting of block between Ionakhsh Fault and Fault 35.	Almost certain	3. Creeping of Fault 70 or subsidiary faults.	Likely	<table border="1"> <thead> <tr> <th>IMPACT (S)</th> <th>Evaluation</th> </tr> </thead> <tbody> <tr> <td>1. Deformation of dam foundation (around 0.3m in 100 years).</td> <td>Minor</td> </tr> <tr> <td>2. Damage to hydraulic tunnel lining, may lead to collapse.</td> <td>Major</td> </tr> <tr> <td>3. Progressive inclination of turbines axis.</td> <td>Major</td> </tr> </tbody> </table>		IMPACT (S)	Evaluation	1. Deformation of dam foundation (around 0.3m in 100 years).	Minor	2. Damage to hydraulic tunnel lining, may lead to collapse.	Major	3. Progressive inclination of turbines axis.	Major	<table border="1"> <thead> <tr> <th colspan="2">Risk</th> </tr> </thead> <tbody> <tr> <td>ADOPTED</td> <td></td> </tr> </tbody> </table>		Risk		ADOPTED					
CAUSE (S)	Likelihood																														
1. Creeping movement Ionakhsh / Fault 35.	Almost certain																														
2. Tilting of block between Ionakhsh Fault and Fault 35.	Almost certain																														
3. Creeping of Fault 70 or subsidiary faults.	Likely																														
IMPACT (S)	Evaluation																														
1. Deformation of dam foundation (around 0.3m in 100 years).	Minor																														
2. Damage to hydraulic tunnel lining, may lead to collapse.	Major																														
3. Progressive inclination of turbines axis.	Major																														
Risk																															
ADOPTED																															
MITIGATION MEASURES		<table border="1"> <thead> <tr> <th>CAUSE (S)</th> <th>Likelihood</th> </tr> </thead> <tbody> <tr> <td>1. Creeping movement Ionakhsh / Fault 35.</td> <td>Almost certain</td> </tr> <tr> <td>2. Tilting of block between Ionakhsh Fault and Fault 35.</td> <td>Almost certain</td> </tr> <tr> <td>3. Creeping of Fault 70 or subsidiary faults.</td> <td>Likely</td> </tr> </tbody> </table>		CAUSE (S)	Likelihood	1. Creeping movement Ionakhsh / Fault 35.	Almost certain	2. Tilting of block between Ionakhsh Fault and Fault 35.	Almost certain	3. Creeping of Fault 70 or subsidiary faults.	Likely	<table border="1"> <thead> <tr> <th>IMPACT (S)</th> <th>Evaluation</th> </tr> </thead> <tbody> <tr> <td>1. Deformation of dam foundation (around 0.3m in 100 years).</td> <td>Minor</td> </tr> <tr> <td>2. Damage to hydraulic tunnel lining, may lead to collapse.</td> <td>Moderate</td> </tr> <tr> <td>3. Progressive inclination of turbines axis.</td> <td>Moderate</td> </tr> </tbody> </table>		IMPACT (S)	Evaluation	1. Deformation of dam foundation (around 0.3m in 100 years).	Minor	2. Damage to hydraulic tunnel lining, may lead to collapse.	Moderate	3. Progressive inclination of turbines axis.	Moderate	<table border="1"> <thead> <tr> <th colspan="2">Risk</th> </tr> </thead> <tbody> <tr> <td>ADOPTED</td> <td></td> </tr> </tbody> </table>		Risk		ADOPTED					
CAUSE (S)	Likelihood																														
1. Creeping movement Ionakhsh / Fault 35.	Almost certain																														
2. Tilting of block between Ionakhsh Fault and Fault 35.	Almost certain																														
3. Creeping of Fault 70 or subsidiary faults.	Likely																														
IMPACT (S)	Evaluation																														
1. Deformation of dam foundation (around 0.3m in 100 years).	Minor																														
2. Damage to hydraulic tunnel lining, may lead to collapse.	Moderate																														
3. Progressive inclination of turbines axis.	Moderate																														
Risk																															
ADOPTED																															
RESIDUAL RISK (after mitigation)		<table border="1"> <thead> <tr> <th>CAUSE (S)</th> <th>Likelihood</th> </tr> </thead> <tbody> <tr> <td>1. Creeping movement Ionakhsh / Fault 35.</td> <td>Almost certain</td> </tr> <tr> <td>2. Tilting of block between Ionakhsh Fault and Fault 35.</td> <td>Almost certain</td> </tr> <tr> <td>3. Creeping of Fault 70 or subsidiary faults.</td> <td>Likely</td> </tr> </tbody> </table>		CAUSE (S)	Likelihood	1. Creeping movement Ionakhsh / Fault 35.	Almost certain	2. Tilting of block between Ionakhsh Fault and Fault 35.	Almost certain	3. Creeping of Fault 70 or subsidiary faults.	Likely	<table border="1"> <thead> <tr> <th>IMPACT (S)</th> <th>Evaluation</th> </tr> </thead> <tbody> <tr> <td>1. Deformation of dam foundation (around 0.3m in 100 years).</td> <td>Minor</td> </tr> <tr> <td>2. Damage to hydraulic tunnel lining, may lead to collapse.</td> <td>Moderate</td> </tr> <tr> <td>3. Progressive inclination of turbines axis.</td> <td>Moderate</td> </tr> </tbody> </table>		IMPACT (S)	Evaluation	1. Deformation of dam foundation (around 0.3m in 100 years).	Minor	2. Damage to hydraulic tunnel lining, may lead to collapse.	Moderate	3. Progressive inclination of turbines axis.	Moderate	<table border="1"> <thead> <tr> <th colspan="2">Risk</th> </tr> </thead> <tbody> <tr> <td>ADOPTED</td> <td></td> </tr> </tbody> </table>		Risk		ADOPTED					
CAUSE (S)	Likelihood																														
1. Creeping movement Ionakhsh / Fault 35.	Almost certain																														
2. Tilting of block between Ionakhsh Fault and Fault 35.	Almost certain																														
3. Creeping of Fault 70 or subsidiary faults.	Likely																														
IMPACT (S)	Evaluation																														
1. Deformation of dam foundation (around 0.3m in 100 years).	Minor																														
2. Damage to hydraulic tunnel lining, may lead to collapse.	Moderate																														
3. Progressive inclination of turbines axis.	Moderate																														
Risk																															
ADOPTED																															

GENERAL INFORMATION		Rogun HPP		TEAS Consortium - Phase II - Risk assessment		07/08/2014	
		Sheet n°		15B		Risk ID	
						Co-sismic displacements	
						Flood management system	
						Risk evaluation	
		Before mitigation		After mitigation			
IDENTIFICATION		CAUSE		IMPACT			
		Level 1: Natural		SYSTEM (S): Flood management system; COMPONENT (S): Diversion Tunnels 1,2,3			
		Level 2: Geology / Geotechnics / Geomechanics		Flood management system; Mid Level tunnels 1,(2)			
		Level 3: Co-sismic displacements		Flood management system; High level Tunnels 1, (2), (3)			
		Flood management system; Surface spillway					
DESCRIPTION (before mitigation)		CAUSE (S)		IMPACT (S)		Evaluation	
		1. Co-sismic displacement along Ionakhsh Fault (assumed 1m). 2. Co-sismic displacement along Fault 35 or subsidiaries (assumed 0.1m). 3. Co-sismic displacement along Fault 35 or subsidiaries (assumed 0.1m).		1. Damage to diversion tunnels and mid-level outlet 1. 2. Damages to high level tunnels depending on moving fault location. 3. Damages to surface spillway depending on moving fault location.		Extreme Moderate Moderate	
		Likelihood: Moderate				Risk	
		Comments		Comments		ADOPTED	
		a. Co-sismic displacement along Ionakhsh Fault during an earthquake : 1m maximum according to seismo-tectonic studies. b. The risk only counts during the useful life of tunnels DT3 and ML1, only during construction period for less than about 10 years. c. Co-sismic displacement along Fault 35 and subsidiary faults of the same family during an earthquake: 0.1m maximum according to seismo-tectonic studies. d. Regarding diversion tunnels and mid-level outlet 1, co-sismic displacement along Fault 35 can induce some damages, but moderate comparing to these induced by Ionakhsh Fault.		a. Only the DT3 and middle outlet 1 are crossed by Ionakhsh Fault. Co-sismic displacement on Ionakhsh Fault will affect the portals of the diversion tunnels 1 and 2, as well as diversion tunnel 3 and the mid-level outlet 1; mis-alignment of tunnel blocks and damage to lining of the hydraulic tunnels may lead rapidly to tunnel collapse due to ground scouring by water under high velocity; cavitation and headlosses also expected. b. In the case of Surface Spillway, being and outdoor structures, monitoring and repair works become easier. The project is less sensitive to this kind of risk. c. Co-sismic displacement along Fault 35 or other faults of the same family is to affect a great number of tunnels, almost all of the principal hydraulic and access tunnels; damage to lining of hydraulic tunnels may rapidly lead to tunnel collapse due to ground scouring by water under high velocity; cavitation and headlosses also expected.			
MITIGATION MEASURES		Recommended mitigation measures		Recommended mitigation measures			
				1 - 2 - 3. Special design of lining of hydraulic tunnels crossing potentially active faults, avoiding scouring. / Allow stopping the operation and immediate inspection and repair of all hydraulic tunnels after a major earthquake where co-sismic displacement may or has occurred. For DT3, a second gates cavern in order to allow sectionnal inspection and repair works. For Middle Outlet 1, an enlarge colvert in the crossing area.			
		Comments		Comments			
				a. Special design to reduce the impact of a co-sismic movement on the tunnel and above all, avoid scouring (overexcavation and placement of rings of reinforced concrete lining separated by joints) b. Fitting the hydraulic tunnels with adequate stoplogs/valves to allow rapid inspection of hydraulic tunnels; available means for repair. c. A monitoring system to detect tunnel shearing, and seepage.			
RESIDUAL RISK (after mitigation)		CAUSE (S)		IMPACT (S)		Evaluation	
		1. Co-sismic displacement along Ionakhsh Fault (assumed 1m). 2. Co-sismic displacement along Fault 35 or subsidiaries (assumed 0.1m). 3. Co-sismic displacement along Fault 35 or subsidiaries (assumed 0.1m).		1. Damage to diversion tunnels and mid-level outlet. 2. Damages to high level tunnels depending on moving fault location. 3. Damages to surface spillway depending on moving fault location.		Major Minor Minor	
		Likelihood: Moderate				Risk	
		Comments		Comments		ADOPTED	
		a. If co-sismic movement occurs along a fault not fitted with specially designed lining. b. If the special design measures reveal not adequate, or not completely effective, especially towards scouring, e.g. in case the fault shear movement concentrates along a very narrow strip, like a saw cut.		a. If movement occurs where no special measures have been, taken the level of risk is same as without mitigation measure. b. If special design measures where crossing potentially active faults is not effective, the good implementation of reinforced concrete lining should limit penetration in the ground of the high-velocity flowing water, and reinforcement preserves stability for at least some time until inspection and repair can be achieved.			



GENERAL INFORMATION		Rogun HPP		TEAS Consortium - Phase II - Risk assessment		07/08/2014																					
		Sheet n°		17		Risk ID																					
		Structures-Caverns: rock excavation		Power & Energy system		Risk evaluation																					
		Before mitigation		After mitigation																							
IDENTIFICATION		<table border="1"> <thead> <tr> <th colspan="2">CAUSE</th> </tr> </thead> <tbody> <tr> <td>Level 1</td> <td>Natural</td> </tr> <tr> <td>Level 2</td> <td>Geology / Geotechnics / Geomechanics</td> </tr> <tr> <td>Level 3</td> <td>Structures-Caverns: rock excavation</td> </tr> </tbody> </table>		CAUSE		Level 1	Natural	Level 2	Geology / Geotechnics / Geomechanics	Level 3	Structures-Caverns: rock excavation	<table border="1"> <thead> <tr> <th colspan="2">IMPACT</th> </tr> <tr> <th>SYSTEM (S)</th> <th>COMPONENT (S)</th> </tr> </thead> <tbody> <tr> <td>1. Power &amp; Energy system</td> <td>Powerhouse</td> </tr> <tr> <td>2. Power &amp; Energy system</td> <td>Transformers</td> </tr> </tbody> </table>		IMPACT		SYSTEM (S)	COMPONENT (S)	1. Power & Energy system	Powerhouse	2. Power & Energy system	Transformers						
CAUSE																											
Level 1	Natural																										
Level 2	Geology / Geotechnics / Geomechanics																										
Level 3	Structures-Caverns: rock excavation																										
IMPACT																											
SYSTEM (S)	COMPONENT (S)																										
1. Power & Energy system	Powerhouse																										
2. Power & Energy system	Transformers																										
DESCRIPTION (before mitigation)		<table border="1"> <thead> <tr> <th>CAUSE (S)</th> <th>Likelihood</th> </tr> </thead> <tbody> <tr> <td>1. Non-manageable distressing of rock between caverns.</td> <td>Almost certain</td> </tr> <tr> <td>2. Non-manageable distressing of rock between caverns.</td> <td>Almost certain</td> </tr> </tbody> </table>		CAUSE (S)	Likelihood	1. Non-manageable distressing of rock between caverns.	Almost certain	2. Non-manageable distressing of rock between caverns.	Almost certain	<table border="1"> <thead> <tr> <th>IMPACT (S)</th> <th>Evaluation</th> </tr> </thead> <tbody> <tr> <td>1. Convergence of the Powerhouse cavern.</td> <td>Extreme</td> </tr> <tr> <td>2. Convergence of the Transformers cavern.</td> <td>Moderate</td> </tr> </tbody> </table>		IMPACT (S)	Evaluation	1. Convergence of the Powerhouse cavern.	Extreme	2. Convergence of the Transformers cavern.	Moderate	<table border="1"> <thead> <tr> <th colspan="2">Risk</th> </tr> </thead> <tbody> <tr> <td></td> <td style="background-color: red;"></td> </tr> <tr> <td></td> <td style="background-color: yellow;"></td> </tr> <tr> <td>ADOPTED</td> <td style="background-color: red;"></td> </tr> </tbody> </table>		Risk						ADOPTED	
CAUSE (S)	Likelihood																										
1. Non-manageable distressing of rock between caverns.	Almost certain																										
2. Non-manageable distressing of rock between caverns.	Almost certain																										
IMPACT (S)	Evaluation																										
1. Convergence of the Powerhouse cavern.	Extreme																										
2. Convergence of the Transformers cavern.	Moderate																										
Risk																											
ADOPTED																											
MITIGATION MEASURES		<table border="1"> <thead> <tr> <th colspan="2">Recommended mitigation measures</th> </tr> </thead> <tbody> <tr> <td colspan="2">1-2. Immediate placement of heavy additional support to try to stabilise the cavern.</td> </tr> <tr> <td colspan="2">/ Performance of real time monitoring, with additional means.</td> </tr> <tr> <td colspan="2">/ Extension of cavern towards east, leaving the siltstone part concreted.</td> </tr> </tbody> </table>		Recommended mitigation measures		1-2. Immediate placement of heavy additional support to try to stabilise the cavern.		/ Performance of real time monitoring, with additional means.		/ Extension of cavern towards east, leaving the siltstone part concreted.		<table border="1"> <thead> <tr> <th colspan="2">Recommended mitigation measures</th> </tr> </thead> <tbody> <tr> <td colspan="2">1. Monitoring of the powerhouse cavern. Should allow close observations and allow alert to be given in time in case of failure.</td> </tr> <tr> <td colspan="2">2. Monitoring of the transformers caverns. Should allow close observations and allow alert to be given in time in case of failure.</td> </tr> <tr> <td colspan="2">1-2. Would allow construction for units 5 and 6 in more favourable geological conditions.</td> </tr> </tbody> </table>		Recommended mitigation measures		1. Monitoring of the powerhouse cavern. Should allow close observations and allow alert to be given in time in case of failure.		2. Monitoring of the transformers caverns. Should allow close observations and allow alert to be given in time in case of failure.		1-2. Would allow construction for units 5 and 6 in more favourable geological conditions.							
Recommended mitigation measures																											
1-2. Immediate placement of heavy additional support to try to stabilise the cavern.																											
/ Performance of real time monitoring, with additional means.																											
/ Extension of cavern towards east, leaving the siltstone part concreted.																											
Recommended mitigation measures																											
1. Monitoring of the powerhouse cavern. Should allow close observations and allow alert to be given in time in case of failure.																											
2. Monitoring of the transformers caverns. Should allow close observations and allow alert to be given in time in case of failure.																											
1-2. Would allow construction for units 5 and 6 in more favourable geological conditions.																											
RESIDUAL RISK (after mitigation)		<table border="1"> <thead> <tr> <th>CAUSE (S)</th> <th>Likelihood</th> </tr> </thead> <tbody> <tr> <td>1. Non-manageable distressing of rock between caverns.</td> <td>Likely</td> </tr> <tr> <td>2. Non-manageable distressing of rock between caverns.</td> <td>Likely</td> </tr> </tbody> </table>		CAUSE (S)	Likelihood	1. Non-manageable distressing of rock between caverns.	Likely	2. Non-manageable distressing of rock between caverns.	Likely	<table border="1"> <thead> <tr> <th>IMPACT (S)</th> <th>Evaluation</th> </tr> </thead> <tbody> <tr> <td>1. Convergence of the Powerhouse cavern.</td> <td>Moderate</td> </tr> <tr> <td>2. Convergence of the Transformers cavern.</td> <td>Minor</td> </tr> </tbody> </table>		IMPACT (S)	Evaluation	1. Convergence of the Powerhouse cavern.	Moderate	2. Convergence of the Transformers cavern.	Minor	<table border="1"> <thead> <tr> <th colspan="2">Risk</th> </tr> </thead> <tbody> <tr> <td></td> <td style="background-color: yellow;"></td> </tr> <tr> <td></td> <td style="background-color: green;"></td> </tr> <tr> <td>ADOPTED</td> <td style="background-color: yellow;"></td> </tr> </tbody> </table>		Risk						ADOPTED	
CAUSE (S)	Likelihood																										
1. Non-manageable distressing of rock between caverns.	Likely																										
2. Non-manageable distressing of rock between caverns.	Likely																										
IMPACT (S)	Evaluation																										
1. Convergence of the Powerhouse cavern.	Moderate																										
2. Convergence of the Transformers cavern.	Minor																										
Risk																											
ADOPTED																											

GENERAL INFORMATION		Rogun HPP		TEAS Consortium - Phase II - Risk assessment		07/08/2014																	
GENERAL INFORMATION					Sheet n° 20		Risk ID Maximum head in tunnels Dam system																
					Risk evaluation Before mitigation: <span style="background-color: red; color: white;">High</span> After mitigation: <span style="background-color: yellow; color: black;">Medium</span>																		
	IDENTIFICATION		<table border="1"> <thead> <tr><th colspan="2">CAUSE</th></tr> </thead> <tbody> <tr><td>Level 1</td><td>Technical</td></tr> <tr><td>Level 2</td><td>Design</td></tr> <tr><td>Level 3</td><td>Maximum head in tunnels</td></tr> </tbody> </table>		CAUSE		Level 1	Technical	Level 2	Design	Level 3	Maximum head in tunnels	<table border="1"> <thead> <tr><th colspan="2">IMPACT</th></tr> <tr><th>SYSTEM (S)</th><th>COMPONENT (S)</th></tr> </thead> <tbody> <tr><td>1. Dam system</td><td>Main dam</td></tr> <tr><td>1. Dam system</td><td>Stage 1 dam</td></tr> </tbody> </table>		IMPACT		SYSTEM (S)	COMPONENT (S)	1. Dam system	Main dam	1. Dam system	Stage 1 dam	
CAUSE																							
Level 1	Technical																						
Level 2	Design																						
Level 3	Maximum head in tunnels																						
IMPACT																							
SYSTEM (S)	COMPONENT (S)																						
1. Dam system	Main dam																						
1. Dam system	Stage 1 dam																						
DESCRIPTION (before mitigation)		<table border="1"> <thead> <tr><th>CAUSE (S)</th><th>Likelihood</th></tr> </thead> <tbody> <tr><td>1. Failure of DT2, DT3, or remote spillways due to high operating head.</td><td>Likely</td></tr> </tbody> </table> <p><b>Comments</b></p> <p>a. Under current conditions (HPI design), tunnels are to be operated under high heads (as much as about 200m for DT2).</p> <p>b. These tunnels are supposed to work permanently and over several years with maximum head in order of the magnitude of 150 / 160 m (DT3, Remote Spillways) and up to 200 m for DT2.</p>		CAUSE (S)	Likelihood	1. Failure of DT2, DT3, or remote spillways due to high operating head.	Likely	<table border="1"> <thead> <tr><th>IMPACT (S)</th><th>Evaluation</th></tr> </thead> <tbody> <tr><td>1. Loss of control. Dam overflowing.</td><td>Extreme</td></tr> </tbody> </table> <p><b>Comments</b></p> <p>a. Such unprecedented high head for permanent, long terms (several years during construction) operation, may lead to loss of control of tunnels because of gate vibration and cavitation. If tunnels fail there will be loss of control of floods heading to dams ( stage 1 and Main dam) collapse.</p> <p>b. If tunnel fail, dam (stage 1 and main dam) will be overflood.</p> <p>c. After construction, the surface spillway make possible the overflood.</p>		IMPACT (S)	Evaluation	1. Loss of control. Dam overflowing.	Extreme	<table border="1"> <thead> <tr><th colspan="2">Risk</th></tr> </thead> <tbody> <tr><td>ADOPTED</td><td style="background-color: red; color: white;">High</td></tr> </tbody> </table>		Risk		ADOPTED	High				
CAUSE (S)	Likelihood																						
1. Failure of DT2, DT3, or remote spillways due to high operating head.	Likely																						
IMPACT (S)	Evaluation																						
1. Loss of control. Dam overflowing.	Extreme																						
Risk																							
ADOPTED	High																						
MITIGATION MEASURES		<table border="1"> <thead> <tr><th>Recommended mitigation measures</th></tr> </thead> <tbody> <tr><td>1. Reducing maximum operating head to 120m.</td></tr> </tbody> </table> <p><b>Comments</b></p> <p>a. See report on Flood management during construction.</p> <p>b. Lower operation head, will required a higher number of tunnels for flood management during construction.</p>		Recommended mitigation measures	1. Reducing maximum operating head to 120m.	<table border="1"> <thead> <tr><th>Recommended mitigation measures</th></tr> </thead> <tbody> <tr><td></td></tr> </tbody> </table> <p><b>Comments</b></p> <p></p>		Recommended mitigation measures															
Recommended mitigation measures																							
1. Reducing maximum operating head to 120m.																							
Recommended mitigation measures																							
RESIDUAL RISK (after mitigation)		<table border="1"> <thead> <tr><th>CAUSE (S)</th><th>Likelihood</th></tr> </thead> <tbody> <tr><td>1. Failure of DT2, DT3, or remote spillways due to high operating head.</td><td>Unlikely</td></tr> </tbody> </table> <p><b>Comments</b></p> <p></p>		CAUSE (S)	Likelihood	1. Failure of DT2, DT3, or remote spillways due to high operating head.	Unlikely	<table border="1"> <thead> <tr><th>IMPACT (S)</th><th>Impact</th></tr> </thead> <tbody> <tr><td>1. Loss of control. Dam overflowing.</td><td>Extreme</td></tr> </tbody> </table> <p><b>Comments</b></p> <p></p>		IMPACT (S)	Impact	1. Loss of control. Dam overflowing.	Extreme	<table border="1"> <thead> <tr><th colspan="2">Risk</th></tr> </thead> <tbody> <tr><td>ADOPTED</td><td style="background-color: yellow; color: black;">Medium</td></tr> </tbody> </table>		Risk		ADOPTED	Medium				
CAUSE (S)	Likelihood																						
1. Failure of DT2, DT3, or remote spillways due to high operating head.	Unlikely																						
IMPACT (S)	Impact																						
1. Loss of control. Dam overflowing.	Extreme																						
Risk																							
ADOPTED	Medium																						

# VOLUME 7: CONCLUSIONS AND RECOMMENDATIONS

## 1 DESIGN APPROACH FOR THE PRESENTED ALTERNATIVES

As per the scope of services defined in the Terms of Reference (ToR), an extensive techno-economic assessment has been carried out on all existing design work to date and made available to the Consultant. All design change recommendations resulting from this assessment strictly comply with the design criteria laid down by the Consultant in Volume 3 Chapter 1 (Design Criteria) of the Phase II Report. These criteria are based on internationally accepted standards and state of the art engineering practice for large hydropower projects. This approach ensures full transparency in the methodologies and concepts adopted in the assessment as well as recommended design changes.

The same strict principles have been applied to the different alternatives presented in this report, ensuring an equal design basis for the presented options. These design criteria have been established with the objective of combining quality, performance, sustainability and cost optimization for all proposed options as further elaborated below.

### 1.1 Quality

The design criteria used in this assessment are based on internationally recognized standards and best industry practice. They aim to guarantee, if the recommendations are strictly followed, that the quality of works potentially derived from these concepts is ensured. Long term safety of the works is of prime importance and is the driving force behind all of the design concepts developed in this report.

### 1.2 Performance

All structures have been designed to ensure optimal performance during the project operation, once safety of operation has been guaranteed.

### 1.3 Sustainability, Environmental and Social Impacts

Long term Safety and Performance of the proposed Rogun project shall be guaranteed. In the particular case of the proposed Rogun project and given the magnitude of the works to be implemented by the Government of Tajikistan, all efforts have been made to ensure that the final

hydro project facility will not become a liability for the Country at any point in time. The assessment has therefore been carried out keeping in mind long term impacts and end of life aspects of the project, once the facility can no longer produce energy.

Environmental and Social impacts of the project on the short term (construction) but also on the long term have been specifically evaluated by the ESIA Consultant in a parallel study. Constant efforts have been made in the TEAS studies to adequately reflect the thorough impact assessment carried out, through a close collaboration with the ESIA Consultant.

#### **1.4 Cost Optimization**

Once Quality, Performance, Safety and Sustainability have been guaranteed, cost optimization is taken into account when completing the design, in line with the best interests of the Client developing the project. Careful consideration has been given to duly incorporate Environmental and Social impact costs in the overall analysis to adequately provision these amounts in the overall project cost.

#### **1.5 Risk Management**

A thorough risk register has been developed for the project to exhaustively identify potential future risks for all alternatives, if the project were to be implemented. All project alternatives have been found to have the same list of risks.

For each identified risk, feasible mitigation measures have been recommended. The objective was in each case to reduce the risks to an acceptable level in compliance with the indicated Quality, Safety, Performance and Sustainability requirements.

## **2 CONTEXT OF THE PROJECT ALTERNATIVES**

The proposed alternatives have been developed taking into account the complex features of the proposed Rogun project, particularly in the context of the following aspects:

## 2.1 Natural Conditions

### 2.1.1 Geology and Salt Dome

The proposed alternatives duly account for the complex geology of the site. An extensive review of the existing data and additional site investigations have allowed, during the course of the assessment, a better understanding of the site conditions, in particular on the downstream right bank.

The presence of a salt body located within the dam footprint of all alternatives has been studied in detail. This is the subject of the Phase 0 Report that includes numerical models and physical investigations to carefully address this issue. All alternatives are equally exposed to the risk inferred by the presence of the salt dome. However, with the implementation of the recommended mitigation measures described in the Phase 0 Report, this risk can be reduced to a level that ensures the long term safety of the proposed dam alternatives.

### 2.1.2 Seismicity

A deterministic approach has led to a preliminary assessment of the seismic design parameters against which the stability of the different dam alternatives shall be ensured. As detailed in the Dam Stability Report, all three different dam alternatives are designed to withstand the Peak Ground Acceleration corresponding to the Maximum Credible Earthquake (estimated to be 0,71g). This is in full compliance with international design criteria adopted for dams of this magnitude.

Co-seismic displacements in case of large earthquakes have been estimated and duly accounted for when designing the project structures (tunnels, etc.).

### 2.1.3 Hydrology

Design floods have been derived from extensive hydrological series. The Probable Maximum Flood (PMF) has been considered as the design flood for all dam alternatives, with a value of 7800 m<sup>3</sup>/s.

Water management studies for the three proposed alternatives and corresponding energy generation have been derived from the same series. The comparison of benefits for each alternative is therefore based on a long data set, considered reliable for determining the economic viability of the proposed design alternatives.

#### **2.1.4 Sedimentation**

The sedimentation study has been based on available data, including existing surveys of the Nurek reservoir. In order to appropriately address uncertainties, the same conservative approach has been used to define the different lifetimes of the proposed alternatives. The annual inflow of sediments in the reservoir has been considered to be 100 million m<sup>3</sup> / year.

It should be noted that due to the high level of sediment inflows in the Vakhsh River, all the proposed dam alternatives have a limited lifetime. The Rogun reservoir is bound to be filled with sediment in a given period of time. Therefore, specific end-of-life strategy for all dam alternatives has been planned.

### **2.2 Existing Assets**

All alternatives have been designed to appropriately incorporate the existing facilities previously constructed at the Rogun site. A thorough assessment of these facilities was carried out and detailed in the Phase I Report. The aim of the assessment was to determine the suitability of these structures with respect to the proposed Rogun alternatives. Where necessary, mandatory remedial measures have been recommended to bring the structures up to the safety and performance standards required for the project.

All three proposed alternatives try to incorporate existing equipment and facilities where possible. It is in the best interests of the Client developing the project to optimize the overall project cost.

Each Rogun alternative is proposed to work in tandem with the Nurek dam in order to derive full benefits from what is a major asset in the overall Tajik existing hydro portfolio. All efforts have been made to ensure energy production maximization of the Nurek HPP during the most extended period possible.

### **2.3 Water Sharing Institutional Framework**

All project alternatives have been defined within the strict constraint that the Vakhsh cascade operation principle downstream of Nurek remains unchanged during the implementation (filling) and operation of any of the Rogun alternatives. In practice this means that, every year, the combined reservoirs of Rogun and Nurek will be operated in a manner ensuring that the water volume transferred from summer to winter is consistent with that transferred at present. Future use

of its water share by Tajikistan has been incorporated in the model, in strict compliance with the existing practice for water allocation on the Vakhsh River.

It should therefore be highlighted that all proposed dam alternatives can be operated under a regime which will not change seasonal water availability in the downstream area and will remain similar to the way the Cascade is operated today. The only sizable change will be future use of Tajik water share initially for filling the Rogun reservoir and then for irrigation, in compliance with the agreements and practice currently in place.

## 2.4 Environmental and Social Impacts

The Environmental and Social Impact Assessment (ESIA) was carried out in parallel by the ESIA consultant based on the technical features of the proposed alternatives defined in the Phase II Report.

The analysis of environmental and social impacts of the three alternatives carried out by the ESIA consultant did not lead to eliminate any of the proposed options. It was verified in considering the comparison of the three alternatives that none of them had unacceptable level of Environmental and/or Social impacts – although the highest dam does require significantly more resettlement than the other two dam height options.

All Environment and Social cost for the different dam alternatives as estimated by ESIA consultant were duly taken into account to derive the overall capital cost of each proposed options. In accordance with the scope of TEAS Consultant, environment and social impacts are therefore reflected in the economic comparison of alternatives.

## 2.5 Electricity Demand Forecast and Market

All the proposed Rogun alternatives will generate electricity that can be used both to meet the domestic demand and as well as provide exports via interconnectors to neighboring countries. A detailed forecast of domestic demand growth, including assessment of currently unmet demand, has been carried out. This analysis forms an integral part of the assessment, ensuring that all the proposed alternatives are adequately adapted to the existing markets and their future trends.



## 2.6 Least Cost Expansion Plan and Economic Analysis

The Least Cost Expansion Plan and Economic Analysis of all proposed Rogun alternatives, show that each Rogun design option is forecast to provide significant total system cost savings and generate positive Net Present Value (NPV) under a wide range of assumptions. This benefit largely derives from the controllable nature of generation from the Rogun project. All the Rogun design alternatives are better suited to demand (in particular in winter) and also provide greater levels of exports than other production alternatives in Tajikistan.

## 3 BROAD CONCLUSIONS OF THE ALTERNATIVES STUDY

### 3.1 Main Technical Features

The same design criteria have been used to derive nine Rogun alternatives as presented in Volume 3 Chapter 3 (Design of Alternatives) of the Phase II Report. These nine design options comprise of three dam height alternatives (FSL 1290 m.a.s.l, FSL 1255 m.a.s.l and FSL 1220 m.a.s.l) with three different installed capacities (MW) for each dam height.

The details for the nine design options, all of which are considered technically feasible, are described below:

#### 3.1.1 Dam Features

	FSL1290	FSL1255	FSL1220
<b>Dam crest (m.a.s.l.)</b>	1300	1265	1230
<b>Foundation level (m.a.s.l.)</b>	965	965	965
<b>Dam height (m.a.s.l.)</b>	335	300	265
<b>Total reservoir capacity (hm<sup>3</sup>)</b>	13 300	8 550	5 220
<b>Stage 1 elevation (m.a.s.l.)</b>	1110	1090	1075

**Table 87 : Dam alternatives main features**

### 3.1.2 EM Equipment Characteristics

<b>Total Capacity Installed (MW)</b>	<b>3600</b>	<b>3200</b>	<b>2800</b>
<b>Number of units</b>	6	6	6
<b>Number of units reused (*)</b>	2	2	2

Table 88 : EM Equipment - Final Dam Elevation 1290 m.a.s.l.

<b>Total Capacity Installed (MW)</b>	<b>3200</b>	<b>2800</b>	<b>2400</b>
<b>Number of units</b>	6	6	6
<b>Number of units reused (*)</b>	2	2	2

Table 89 : EM Equipment - Final Dam Elevation 1255 m.a.s.l.

<b>Total Capacity Installed (MW)</b>	<b>2800</b>	<b>2400</b>	<b>2000</b>
<b>Number of units</b>	6	6	6
<b>Number of units reused (*)</b>	2	2	2

(\*) Adopting final runners since the commissioning

Table 90 : EM Equipment - Final Dam Elevation 1220 m.a.s.l.

### 3.2 Implementation Schedule and Logistics

All alternatives have been thoroughly analyzed to derive a detailed construction schedule. The resulting different construction periods for the three dam alternatives are as presented in the next table:

	<b>FSL 1290</b>	<b>FSL 1255</b>	<b>FSL 1220</b>
<b>TEAS validation and GoT decision to proceed with the Project</b>	0	0	0
<b>River Diversion date</b>	28	28	28
<b>End of cofferdam construction</b>	36	36	36
<b>End of stage 1 dam construction</b>	58	53	49
<b>End of dam construction</b>	163	142	120

Table 91 : Implementation Schedule - Key data 1 - Time from Pre-Contract (in months)

As detailed in the main Phase II Report, the extent to which facilities, existing infrastructure and access tunnels need to be developed for construction works of the magnitude of the proposed Rogun project are similar for all alternatives. Implementing any of the different alternatives will require sustained quality control and organization on site. It is to be noted that the main difference in project construction period is related to the dam fill placement. This means that activities with a high level of risk and contingencies as underground structures and tunnels are of similar nature for the three alternatives. Consequently, in this particular case, an increased construction period does not necessarily mean an increase in implementation risks for a given option.

For all project alternatives, due to the very challenging nature of the Project and of its tight scheduling, the Consultant recommends the careful selection of experienced and highly qualified Main Contractor/Contractors (and potentially Sub-Contractors) as well as Designers and Owner's Engineers.

### 3.3 Early Generation Concept

Considering the long duration of the construction period for all the proposed dam alternatives, an early impounding and early generation concept has been adopted for all options. This will allow for the early generation of benefits during the lengthy implementation (filling) stage of the project.

During construction, the operation of Rogun has also been optimized in order to increase the energy output from the whole cascade as early as possible with the following main results:

Dam alternative	FSL 1290	FSL 1255	FSL 1220
<b>Time to reach Normal Operation</b>	16 years	13 years	9 years
<b>Additional energy produced by the cascade during construction compared with "no Rogun" option</b>	111 TWh	69 TWh	37 TWh
<b>Equivalent years of normal operation</b>	7.7 years	5.5 years	3.7 years

**Table 92 : Energy production during construction for all dam alternatives**

### 3.4 Energy Generation and Date of Commissioning

As discussed above, early generation together with the progressive installation of units (turbines) has been adopted for the project. The main dates of commissioning of the different units are reproduced below and have been derived from a detailed analysis of the implementation schedule:

	FSL 1290	FSL 1255	FSL 1220
TEAS Validation and GoT decision to proceed with the project	0	0	0
Diversion	28	28	28
Commissioning U 6 Temp.	73	73	82 (*)
Commissioning U 5 Temp.	75	75	84 (*)
End of Erection U4	85	85	85
End of Erection U3	98	98	98
End of Erection U2	112	112	112
End of Erection U1	112	112	112
Minimum Reservoir level reach	112	94	80
Temp U5 and U6 shut down	117	114	(*)
Commissioning U 4	115	101	101
Commissioning U 3	117	114	114
Commissioning U 2	119	116	116
Commissioning U 1	121	118	118
Commissioning U 6	123	120	(*)
Commissioning U 5	127	122	(*)

(\*) U5-U6 of alternative FSL1220 are directly installed with final configuration (i.e with final runners and final generators). For alternatives FSL 1255 and 1290 installation is made with final runners and temporary generators.

**Table 93 : Implementation Schedule - Key data 2 – Time from Pre-Contract (in months)**

For the baseline scenario discussed in the Reservoir Operation Chapter (Vol. 3, Chap. 5), the following average yearly energy outputs  $E_{Rogun}$  are expected to be produced by the different proposed design alternatives during normal operation:

Dam Alternative FSL 1290 m.a.s.l	
Capacity	Average Yearly Energy in GWh
3600 MW	$E_{\text{Rogun}}=14\ 398$
3200 MW	$E_{\text{Rogun}}=14\ 288$
2800 MW	$E_{\text{Rogun}}=14\ 066$

**Table 94 : Average Yearly Energy - Dam Alternative FSL 1290 m.a.s.l**

Dam Alternative FSL 1255 m.a.s.l	
Capacity	Average Yearly Energy in GWh
3200 MW	$E_{\text{Rogun}}=12\ 391$
2800 MW	$E_{\text{Rogun}}=12\ 295$
2400 MW	$E_{\text{Rogun}}=12\ 072$

**Table 95 : Average Yearly Energy - Dam Alternative FSL 1255 m.a.s.l**

Dam Alternative FSL 1220 m.a.s.l	
Capacity	Average Yearly Energy in GWh
2800 MW	$E_{\text{Rogun}}=10\ 121$
2400 MW	$E_{\text{Rogun}}=10\ 037$
2000 MW	$E_{\text{Rogun}}=9\ 800$

**Table 96 : Average Yearly Energy - Dam Alternative FSL 1220 m.a.s.l**

### 3.5 Investment Cost

A detailed cost estimate (including unit rate analysis) has been established for the nine proposed alternatives with the same level of accuracy. This was a major input to the economic comparison of the alternatives.

### 3.6 Project Life

As already mentioned above, based in the estimated range of solid run off, the ultimate reservoir lifespan (when there is no more regulation possible in the reservoir) can be calculated for each alternative.

	<b>Operating Lifetime</b>
<b>FSL=1290 masl</b>	115 years
<b>FSL=1255 masl</b>	75 years
<b>FSL=1220 masl</b>	45 years

**Table 97 : Estimated Rogun reservoir ultimate lifespan**

Note that rising of the intakes during the life of the project has been proposed in order to extend the life of each project alternatives to the maximum possible. An annual inflow of sediments of 100 hm<sup>3</sup>/ year has also been assumed to derive these figures.

As discussed in Volume 2 Chapter 6 (Sedimentation), a free surface overflow spillway with adequate aeration and a dissipation device is mandatory. The proposed solution needs to be implemented in order to safely pass on the long term the design flood (i.e. PMF) when the spillway tunnels will cease to function due to blockage by sedimentation.

At this end of life stage, this surface spillway could also discharge the solid inflows and manage the sediment balance, long after the plant and the other spillway facilities will be put out of operation.

For all proposed options, an ultimate end of life management option could be to remove the gates from the surface spillway allowing the sediments to carve an incised channel through the spillway and underlying rock over a period of several decades. This solution is applicable for all proposed alternatives.

## 4 DETERMINATION OF PREFERRED PROJECT CONFIGURATION

### 4.1 Economic Evaluation

The economic analysis demonstrates the economic viability of all the Rogun design options under a range of assumptions.

The FSL 1290 m.a.s.l alternative with installed capacity of 3200 MW shows the highest Total System Cost Saving and the highest Net Present Value of economic benefits. That shows that the incremental cost of implementing the highest alternative is compensated by the incremental benefits derived during the Project life. These results are reinforced with a lower discount rate, which apportions a greater weight to the long term benefits of the Project.

On a purely economic point of view, the highest dam alternative and intermediate installed capacity (FSL 1290 m.a.s.l and 3200 MW) is the most attractive option.

### 4.2 Life Span and Economic Analysis

As shown above, the different proposed dam design alternatives have significantly different life expectancies (115 years, 75 years and 45 years for FSL 1290 m.a.s.l, FSL 1255 m.a.s.l and FSL 1220 m.a.s.l respectively). The difference in lifetime between the proposed dam alternatives is a significant factor as Rogun project is a large investment for Government of Tajikistan as well as a major asset in both the overall energy sector of the country and the region.

Unfortunately, there are limitations in reflecting key economic parameters beyond 50 years, therefore the Least Cost Expansion Plan and Economic Analysis focuses on the period through to 2050. Moreover, long term benefits of such a large project are difficult to adequately assess, despite the inclusion of a terminal value calculation in the analysis, due to the damping effect of the discounting factor. However, the sensitivity analysis on discounting factor carried out clearly shows that any reduction in the discount rate significantly improves the net benefits from the highest dam option (FSL 1290 m.a.s.l) showing that on the long run, the largest dam plays a major long term role in the Tajik energy system.

It is also clear that such a strategic investment for Tajik Government cannot be decided based on a 50 years study window, but should be seen as a legacy for future generations. This is a major argument in favor of the highest dam (FSL 1290 m.a.s.l), that provides the longest project life,

guaranteeing low cost energy production for the longest period to Tajik energy system and more generally to the Region as a strategic export project.

### 4.3 Sustainability and Long Term Management

As previously mentioned, the end of the life management of such a large asset will need to be dealt at the inception of the project and will require large investments (e.g. maintenance of the surface spillway used to evacuate the river flow when the dam will be filled with sediment).

The Consultant recommends putting a de-commissioning fund in place as early as possible, fed with part of the project benefits in order to finance these end of life costs. Financing such a fund will be easier for a project with an extended life that will provide benefits on a much larger period of time. It may also be assumed that engineering practices will have evolved during the life of the project. This definitely goes in favor of the alternatives with a longer life span.

### 4.4 Water Sharing Institutional Framework Opportunities

The different proposed Rogun dam alternatives will not impact the seasonal flow pattern downstream of Nurek. In addition, the operation strictly complies with existing agreements and practices on allocation of water shares. However, in this operative mode the largest reservoir at FSL 1290 m.a.s.l and the intermediate reservoir at FSL 1255 m.a.s.l, will not be fully utilized and have a large unused live storage capacity.

This could represent a potential opportunity for cooperation within the entire Amudarya basin, bringing additional storage capacity that could be possibly mobilized during dry years to sustain the irrigation needs of the riparian countries. The highest dam alternative provides the greatest potential for storage and the associated economic benefits this could bring. Trade off mechanisms would need to be institutionalized between the concerned countries to better leverage these benefits as well as ensure the long-term viability of such a benefit-sharing approach.

Significant potential for the highest dam option (FSL 1290 m.a.s.l) and possibly the intermediate option (FSL 1255 m.a.s.l) may be reaped if international agreements can be agreed upon with downstream countries.



#### 4.5 Extreme Flood Safety of Vakhsh Cascade

As explained in Volume 3 Chapter 3, the Vakhsh Cascade as of today is not designed to handle the PMF. This is in particular true for Nurek Dam, one of the largest dams in the world.

Simulations show that only dam alternatives with FSL at 1290 m.a.s.l and 1255 m.a.s.l can safely handle the PMF and protect the downstream structures from overtopping. This function cannot be guaranteed by the lowest dam alternative (FSL 1220 m.a.s.l), requiring immediate implementation of large upgrading works on the downstream structures, that could correspond to an overall investment up to 1 billion USD for the full cascade.

Due to the limited life expectancy of the FSL 1255 m.a.s.l alternative (75 years), and in order to ensure that such a positive benefit is being brought to the cascade safety for the longest period of time, it would be more effective to implement the FSL 1290 m.a.s.l alternative.

This is also consistent with the idea of end-of-life funds to be gathered during project life to ensure financing of upgrade works required for downstream projects to safely pass the PMF. The 1 billion USD investments will in any case be required when storage capacity will be lost for all alternatives, and consequently in a farther horizon for the highest dam alternative.

The Consultant recommends putting in place a flood forecasting system: during exceptional years where conditions could be favorable to the occurrence of an extreme flood of the magnitude of the PMF, the reservoir levels of Rogun and Nurek would need to be lowered before the flood season

#### 4.6 Climate Change and Carbon Release Avoidance

Reservoir projects are found to be more adaptive to variations in design flood due to climate change. The additional reservoir capacity for flow regulation available in the two highest dam alternatives and unused in the present simulation can bring more flexibility to handle hydrology variability. This could be increase in the design flood (PMF) or better management of dry years, depending on the effects of Climate Change in future. This goes in favor of the alternatives with the most unused storage capacity and gives more potential to the higher dam alternatives.

Moreover, generation from reservoir projects can substitute generation using fossil fuels, leading to a reduction in emissions of carbon dioxide ("CO<sub>2</sub>"). The bigger the annual hydropower energy

produced, the higher the avoided emissions and therefore the potential benefits from CO<sub>2</sub> emissions savings. This argument favors the highest dam alternatives.

#### 4.7 Installed Capacity and Peaking

The Least Cost Expansion Plan undertaken for Tajikistan and its neighbors suggests that the incremental net benefit of adding capacity beyond a particular point is limited. Note that average annual generation (measured in terms of energy, MWh) from each dam alternative is very similar and not affected by installed capacity. The benefit of additional peak capacity (measured in capacity MW available at times of peak demand) is limited by interconnector constraints and the level of achievable prices in Tajikistan and Pakistan (which is the principle export market for Tajikistan). This explains why the 3600 MW option at FSL 1290 m.a.s.l is less attractive than the 3200 MW according to the economic analysis undertaken thus far.

However, there are other criteria to consider such as the option of expanding installed capacity later on. One solution could be to leave one unit pit empty and decide on the installation of another unit at a later stage. Moreover if the incremental cost of adding one unit is not major, it should be noted that this additional unit could bring more flexibility in the generating system by allowing standby periods for maintenance without loss of overall annual energy generation. The incremental cost would be recovered by the avoided loss of generation during maintenance. This has to be studied in more details in the next phase of the studies as a final optimization of the selected option.

## 5 CONCLUSION AND RECOMMENDATION

Based on the above considerations, the Consultant recommends that the highest dam alternative (FSL = 1290 m.a.s.l) is taken forward for detailed consideration: This alternative will become a major asset in the Tajik generation system as well as the regional energy market, providing sustained low cost production for the longest time span. It will also protect the Vakhsh Cascade against extreme floods with no additional investment for the longest period, avoiding large rehabilitation works to be implemented on the Cascade.

As the economic results provided by the different installed capacities alternatives are relatively similar, it is recommended that the final optimization of the unit sizing be studied in more detail. Based on the analysis performed for Phase II, it appears that an intermediate installed capacity

would be sufficient (3200 MW), because of the difference in initial equipment investment and very little additional energy generation from a greater installed capacity option.

A number of recommendations have been made on further investigations and analyses that should be carried out for the detailed design of the project.

## 6 DETAILS OF THE RECOMMENDED ALTERNATIVE

### 6.1 Dam

	<b>FSL = 1290 masl</b>
<b>Dam crest</b>	1300 masl
<b>Foundation level</b>	965 masl
<b>Dam height</b>	335 m
<b>Crest length</b>	660 m
<b>Crest width</b>	20 m
<b>Core crest level</b>	1296.25 masl
<b>Maximum water level</b>	1296 masl
<b>Minimum operational level</b>	1185 masl
<b>Reservoir active storage</b>	10 300 hm <sup>3</sup>
<b>Total reservoir capacity</b>	13 300 hm <sup>3</sup>
<b>Average yearly inflows</b>	20 100 hm <sup>3</sup>
<b>Dam slopes</b>	US 2.4 H/1V DS 2 H/1V
<b>Stage 1 elevation</b>	1110 masl
<b>Core crest thickness</b>	8 m
<b>Core slopes</b>	US: 0.5 H/1V DS -0.1 h/1V
<b>Filters thickness</b>	US: 2 layers of 10 m each above the minimum operation level and one layer of 10 m below DS : 2 layers of 10 m each

## 6.2 River diversion structures

	<b>FSL = 1290 masl</b>
<b>Diversion tunnel 1</b>	
<i>Total tunnel length</i>	1439.5 m
<i>Pressure Stretch Section (D-Shape)</i>	96.55 m <sup>2</sup>
<i>Low intake level</i>	989.60 masl
<i>High intake level</i>	1020 masl
<i>Design head</i>	120 m
<i>Minimum operational level</i>	989.60 masl
<i>Maximum operational level</i>	1110 masl
<i>Design discharge</i>	2490 m <sup>3</sup> /s
<b>Diversion tunnel 2</b>	
<i>Total tunnel length</i>	1420.7 m
<i>Pressure Stretch Section (D-Shape)</i>	96.55 m <sup>2</sup>
<i>Low intake level</i>	1001.80 masl
<i>High level intake</i>	1020 masl
<i>Design head</i>	120 m
<i>Minimum operational level</i>	1001.80 masl
<i>Maximum operational level</i>	1110 masl
<i>Design discharge</i>	2490 m <sup>3</sup> /s
<b>Diversion tunnel 3</b>	
<i>Total tunnel length</i>	1560 m
<i>Diameter of Pressure Stretch</i>	15 m
<i>Intake level</i>	1035.0 masl
<i>Outlet portal level</i>	1023.45 masl
<i>Design head</i>	150 m
<i>Minimum operational level</i>	1035 masl
<i>Maximum operational level</i>	1160 masl
<i>Design discharge</i>	3694 m <sup>3</sup> /s

*The data refer to the condition of maximum exceptional head.*

## 6.3 Spillways

### 6.3.1 Middle level outlet

	<b>FSL = 1290 masl</b>
<b>Middle level outlet 1</b>	
<i>Total tunnel length</i>	1464.0 m
<i>Diameter of Pressure Stretch (Circular)</i>	15 m
<i>Intake level</i>	1083.50 masl
<i>Outlet tunnel level</i>	1077.60 masl
<i>Design head</i>	150 m
<i>Minimum operational level</i>	1100.0 masl
<i>Maximum operational level</i>	1215.0 masl
<i>Design discharge</i>	3685 m <sup>3</sup> /s
<b>Middle level outlet 2</b>	
<i>Total tunnel length</i>	1117.0 m
<i>Diameter of Pressure Stretch (Circular)</i>	15 m
<i>Intake level</i>	1140 masl
<i>Outlet tunnel level</i>	1026.80 masl
<i>Design head</i>	150 m
<i>Minimum operational level</i>	1155 masl
<i>Maximum operational level</i>	1270 masl
<i>Design discharge</i>	3710 m <sup>3</sup> /s

*The data refer to the condition of maximum exceptional head.*

### 6.3.2 High level tunnels

	<b>FSL = 1290 masl</b>
<b>High level tunnel 1</b>	
<i>Total tunnel length</i>	1264.1 m
<i>Diameter of Pressure Stretch (Horse-shoe)</i>	10 m
<i>Intake level</i>	1190 masl
<i>Outlet tunnel level</i>	1177.70 masl
<i>Outlet Structure level</i>	1000.00 masl
<i>Outlet Spillway length</i>	440.3 m
<i>Design head</i>	100 m
<i>Minimum operational level</i>	1190 masl
<i>Maximum operational level</i>	1290 masl
<i>Design discharge</i>	1570 m <sup>3</sup> /s
<b>High level tunnel 2</b>	
<i>Total tunnel length</i>	1410.1 m
<i>Diameter of Pressure Stretch (Horse –shoe)</i>	10 m
<i>Intake level</i>	1190 masl
<i>Outlet tunnel level</i>	1176.57 masl
<i>Outlet Structure level</i>	1000 masl
<i>Outlet Spillway length</i>	415.9 m
<i>Design head</i>	100 m
<i>Minimum operational level</i>	1190 masl
<i>Maximum operational level</i>	1290 masl
<i>Design discharge</i>	1570 m <sup>3</sup> /s
<b>High level tunnel 3</b>	
<i>Total tunnel length</i>	
<i>Diameter of Pressure Stretch (Horse –shoe)</i>	
<i>Intake level</i>	
<i>Outlet tunnel level</i>	
<i>Outlet Structure level</i>	
<i>Outlet Spillway length</i>	

	<b>FSL = 1290 masl</b>
<i>Design head</i>	
<i>Minimum operational level</i>	
<i>Maximum operational level</i>	
<i>Design discharge</i>	

The data refer to the condition of maximum exceptional head.

### 6.3.3 Multi-level Intakes

	<b>FSL = 1290 masl</b>
<i>Intakes culverts developed length</i>	312.5 m
<i>Culverts Inner Dimensions</i>	16 x 12 m
<i>Upper Power Intakes level (Units 1, 2, 5, 6)</i>	1167 masl
<i>Lower Power Intakes level (Units 3, 4)</i>	1152 masl
<i>Number of Intakes active inlets</i>	4
<i>Higher Intakes active inlets level</i>	1179.3 masl
<i>Lower Intakes active inlets level</i>	1104.3 masl
<i>Power Intakes Gates Design Head</i>	140 m



### 6.3.4 Surface spillway

	<b>FSL = 1290 masl</b>
<b>First Stage</b>	
<i>Number of modules</i>	1
<i>Number of tunnels</i>	2
<b>Final Stage</b>	
<i>Number of modules</i>	3
<i>Number of tunnels</i>	6
<b>Tunnel width (D-shape)</b>	9.40 m
<b>Tunnel height (D-shape)</b>	15 m
<b>Fall height</b>	224 m
<b>Number intermediate spillways</b>	2
<b>Width of intermediate spillways</b>	33 m
<b>Design discharge (PMF)</b>	7800 m <sup>3</sup> /s
<b>Sill level</b>	1284 masl
<b>Flip bucket exit level</b>	1060 masl
<b>Minimum operational level</b>	1284 masl
<b>Maximum operational level</b>	1296 masl

## 6.4 Power house and EM Equipment

<b>Total Capacity Installed (MW)</b>	<b>3600</b>	<b>3200</b>	<b>2800</b>
<b>Number of units</b>	6	6	6
<b>Number of units reused (*)</b>	2	2	2
<b>Pmax (MW)</b>	615	533.3	466.7
<b>Pmin (MW)</b>	360	270	245
<b>Hmax (m)</b>	320	320	320
<b>Hmin (m)</b>	185	185	185
<b>Hrated (m)</b>	285	285	285
<b>rpm</b>	166.7	166.7	166.7

# **APPENDIX A: SUMMARY OF MAIN RECOMMENDATIONS OF INVESTIGATIONS, TESTS AND STUDIES TO BE PERFORMED EARLY IN THE NEXT STAGES OF THE PROJECT**

## Introduction

This appendix recalls the main recommendations for further investigations, tests and studies to be carried out early in the next stages of the project, as presented in the reports of Phases 0, I and II.

Design changes with respect to the original design as well as design recommendations and detailed design studies for the next phase of project development are not include here. Only the specific recommendations are listed here. For better understanding of background and context as well as for their justification, please refer to the corresponding part of the report.

## Phase 0 – RP38 – Geological and geotechnical investigation of the salt dome in the dam foundation and reservoir

- RP38-01 Accurate in-site measurement of the salt dome rise has to start immediately. This value is crucial for the dissolution rate prediction and models reliability. This measurement could be conducted with the following types of device:
- measurement of the displacements within the salt wedge and the embedding rock,
  - follow-up of the deformations within the salt body by series of clinometers.
- RP38-02 Three monitoring of the salt leaching are proposed to be implemented:
- groundwater head monitoring, in order to check the hydraulic barrier efficiency,
  - water conductivity monitoring to check the model reliability and the on-going leaching process if any,
  - microgravity in order to check rate at Ionakhsh Fault and cavity generation.
- RP38-03 The dissolution numerical model is to be enhanced and recalibrated with more accurate values of hydraulic conductivity and kinematic porosity of the cap aquifer, based on the results of the recommended measurements.

## Phase I – RP39 – Assessment of the existing Rogun HPP works

- RP39-01 For tunnels, further analyses will have to be carried out in a subsequent detailed design phase, to develop the most appropriate strengthening measures applicable to the different tunnels stretches; taking especially in consideration:
- local conditions (rock mass characteristics, structure location),
  - loads due to rock-lining interaction,
  - seismic loads,
  - water pressure, not less than 200 kPa for all stretches upstream from fault 35 and 100 kPa for stretches downstream from the same.
- RP39-02 Interpretation of the tests conducted on rock samples from the powerhouse so to better define the rock mass parameters and behavior of the siltstone
- RP39-03 Before implementing any of the recommended stabilization measures, further analyses are required, by means of a three-dimensional model built on the basis of the existing and of the latest information relevant to the rock mass conditions.

## Phase II Vol. 2 Chap. 2 Part A – RP34 – Assessment of geological conditions

### ***Recommended investigations related to the general geological setting:***

- RP34-01 Nature of the boundary of the atypical zone: exploratory gallery, monitoring of the boundary zone underground and at the surface. To conclude the rehabilitation works in gallery #1034. If major fracture zones are crossed, both these galleries could be equipped with devices for monitoring the deformation.
- RP34-02 Piezometric levels –in particular in the upper part of the right bank, for the design of the grout curtain, and on the downstream slope for designing a drainage system to control the pore pressure: drilling with permeability tests and installation of piezometers.
- RP34-03 Geotechnical characteristics of construction materials.
- RP34-04 Monitoring of slopes and fault displacements.

### ***Recommended investigations related to seismic and aseismic deformation:***

- RP34-05 Refinement of the kinematic model to account for diffuse shearing related with creeping and adjustment of tectonic blocs. If diffuse shearing is confirmed, the location of shearing of underground structures would be unpredictable and reinforced support measures would have to be designed and extended to the entire development of the structures.
- RP34-06 Additional investigations are recommended to verify the cause of damages to support at all identified locations. If necessary, the rock mass should be exposed for inspection and for installation of monitoring devices. Monitoring of displacements along the main faults should be resumed and additional devices installed. In addition, monitoring should be extended to the major discontinuities showing offset which is consistent with present-day stress orientation. In this respect, the anomalous results obtained for the orientation of the principal stress components should also be verified by additional tests. Taking into account the complex tectonic setting, these tests should be also carried out at different locations into the abutments.

### ***Recommended investigations related to risk of landslide:***

- RP34-07 In the left bank, upstream of the dam and including the slopes above the diversion and intake tunnels: the risk is related with gravitational sliding on daylighting discontinuities of S4 family. It is recommended to precisely identify the persistent joints and to carry out stability calculations taking into account the effect of increasing pore pressure upon impounding and fluctuation of reservoir level.
- RP34-08 In the right bank, design adequate drainage system for the main slope downstream of the dam site. For this purpose, additional investigations are recommended to determine the permeability and the ground water level. These investigations should comprise a line of minimum 5 boreholes in the atypical zone, starting at elevation 1350 m, 100 - 150 m deep or sufficient to intercept the ground water level, spaced at 100 m. Accordingly, the geological setting is rather favorable for the slope stability.

The risk of rock mass failure could be increased if mitigation measures for controlling the pore pressure are disregarded.

- RP34-09 In the reservoir, potential rockslides could be triggered by dissolution of salt in the foot of the northern slopes of the Vakhsh Ridge and Surkhku Ridge. Near the dam site, such slides are still developing in the right bank of the Passimurakho valley. Further upstream in the reservoir, the evaporite masses outcrop at elevations higher than the reservoir but their lower part lies below the reservoir level, covered by alluvial deposits. The probability of occurrence of massive and sudden landslides seems low, but the impact can be high. Even if in the past the processes were slow, the impounding will mark a rapid change of the natural conditions. Consequently, it is recommended to assess the response to impounding, the period necessary to reach a new balance with the reservoir water and the response to reservoir level fluctuations, in particular for the slopes in both banks of the Vakhsh River near the entrance in the canyon of the dam site.

### Phase II Vol. 2 Chap. 2 Part B – RP29 – Geology of the Right Bank

- RP29-01 Recommended investigations in the right bank atypical zone:
- follow up of the geodetic system implemented,
  - complete rehabilitation of gallery 1034,
  - excavate an exploratory drift around elevation 1100 m asl across this linement
  - if major fractured zones are crossed, both these galleries could be equipped with devices for monitoring deformation.
- RP29-02 Recommended investigations to limit risk of landslide:
- complete identification of potential areas of landslide or of potential instability in order to define proper mitigation measures (slope reshaping, drainage),
  - complete characterization of pore pressure field in order to assess pore pressure increase during the project life, thus leading to implementation of the corresponding mitigation measures.

### Phase II Vol. 2 Chap. 3 – RP45 – Geotechnics

- RP45-01 Co-seismic, diffuse and creeping movements along faults: see RP34.
- RP45-02 *Right bank disturbed zone:* additionally to the recommendations in RP39, also consider:
- install inclinometers to locate failure surface(s) and characterize the type of movement of this mass,
  - excavation of an investigation gallery, which may be the extension of investigation gallery 1001 within the “disturbed zone”,
  - incorporate the “disturbed zone” into the hydrogeological model is recommended, to fine-tune actual results. This also requires the knowledge of the arrangement of geological formations below reservoir level.
- RP45-03 *Stability of upstream left bank slopes:*
- creeping of rock masses along joints of set 4 (of similar attitude as Fault 35) has been identified and deemed to be the cause for damages to the portals of the

construction tunnels. Since those rock masses will be located just upstream of the dam, dedicated geological and geotechnical investigations are to be carried out in this area to design the reinforcement measures to be taken. Especially, location of faults, thickness, geometry and persistence is to be investigated. Monitoring of the slopes, considering the importance of the issue, is a must.

RP45-04

Additional geotechnical investigations:

- Investigations of formerly collapsed zones in the construction tunnels are also to be performed for their safe design (collapses have left voids up to 25 m or even more above the vault of the tunnel where crossing Fault 35).
- Geotechnical tests on rock materials, comprising laboratory tests and in-situ tests is recommended to be performed in the area of the surface spillway.
- Specific geotechnical investigations for the salt wedge of the Ionakhsh Fault are dealt with in report RP38.
- Investigations for constructions materials are dealt in report RP51.
- Considering the presence of the salt wedge of Ionakhsh Fault, and presence of gypsum in various proportions within the dam foundation, all construction materials, and primarily cement, shall be sulphate-resistant. Properties of construction materials are to be checked in this sense.
- Additional campaigns of geotechnical testing are to be performed according to internationally recognised standards familiar to Contractors, like ISRM suggested methods, ASTM, or others.

## Phase II Vol. 2 Chap. 4 – RP33 – Seismicity

RP33-01

Two kinds of seismic instrumentation are required, to be implemented as soon as possible in order to estimate the background (base-line) seismicity prior to dam construction:

- **A strong-motion network** (accelerometers) to survey the seismic behavior of the dam under strong earthquakes. For this purpose, accelerometers need to be located in the free field away from the dam, in the dam abutments and in the dam body.
- **A microseismic network** around the dam and in the reservoir region, which could record the background seismicity prior to the start of dam construction (at least two years before is generally the time period recommended) and the seismicity during construction, the first filling of the reservoir and the subsequent years of reservoir operation. Instruments should be digital seismic stations with velocity sensors. The number of instruments and geographic distribution depend on the desired threshold magnitude, the size of the reservoir lake and the regional seismic network already in place. Six to eight stations seem to be a minimum. A distribution of one station every 5 km is required if the network is to detect events as low as  $M \sim 1.0$ .

## Phase II Vol. 2 Chap. 5 – RP07 – Hydrology

- RP07-01 Use climate change models as tools to set up adaption priorities as they already point out major future impacts: changes in flow regimes on glacier melt driven rivers, changes in seasonal discharge distribution, higher extreme event variability etc. These phenomena have a large impact on hydropower facilities and should therefore be considered when planning new projects as Rogun HPP.
- RP07-02 Perform an adaptive management of resources. For doing this, the following is necessary:
- **Reduce uncertainty:** Research on climate change shall aim at better understanding and modelling climate variations and allow accurate downscaling of results to derive reliable trends on short as well as long term periods. This would allow incorporating trends in the planning of facilities (design criteria) but also in the economic viability of a project (inflow variability could be incorporated in financial and economic forecasts for project viability).
  - **Reduce Vulnerability:** Better understanding the potential threats would allow also identifying the most vulnerable populations expected to be affected and incorporate mitigation measures in the planning of projects (flood control etc.).
  - **Change use, location etc.:** When such mitigation measures appear to be difficult or non-viable to implement, then direct adjustment to human systems in response to climatic stimuli shall be planned. This could also incorporate potential benefits from climate change impacts as a change in economic opportunities.
  - **Adapt measures and inform:** In the current status of knowledge, any measures taken in order to cope with Climate Change are by essence, subject to adaptation on the short term based on observations. Even a very robust and conservative design shall allow some flexibility for updating to cope with the anticipated drastic changes. This requires a strong observation network and environmental monitoring to be sure to revise and renew adaptation measures as for example upgrade existing facilities. This monitoring system could also strengthen weather forecast and early warning system for minimization of natural disaster risks and increase preparedness to extreme phenomena.
- RP07-03 Recommended flood forecast system:
- A flood forecasting system is to be implemented for optimization of the reservoir operation rules as well as for the establishment of safety procedures.

## Phase II Vol. 2 Chap. 6 – RP43 – Sedimentation

- RP43-01 The evaluation of Vakhsh solid run off should be completed by using state of the art sediment sampling such as pump sediment sampling and laser diffraction technology instruments.
- RP43-02 At this stage of the study and given the data available, some general recommendations in terms of design and operation can be made:
- A complete surface spillway is necessary at long term to safely pass the floods and their solid load,



- Reservoir operation of both Rogun and Nurek will be adapted as the sediments deposit in the reservoir,
- an adaptive water intake for the power waterways should be constructed to lengthen the powerhouse and reservoir life span,
- Ultimately, a desilting device could be designed to keep Rogun operating as a run-off-the-river hydropower plant while discharging the excess sediment load through the proposed surface spillway.

RP43-03 A complete sediment management plan shall take the whole cascade into account and not only the Rogun project to assess the technico-economic efficiency of reservoir by pass and/or new upstream dams.

RP43-04 Further studies and physical hydraulic modelling would be required to design a complete sediment management plan that should be making use of Nurek experience. Therefore, the following is recommended:

- Thorough analysis of Nurek sedimentation thanks to new surveys including echo sounding bathymetry, core sampling, measurement of suspended sediment concentration and particle size distribution;
- Detailed simulation of the Nurek and Rogun sedimentation pattern, including behaviour of turbidity currents;
- Analysis of the possible solutions within the whole cascade scheme.

### **Phase II Vol. 3 Chap. 3 Appendix 1 – RP51 – Construction Materials**

RP51-01 Specific care shall be given to timely extraction of material from BA 15 as this borrow area is bound to be flooded at the early stages of the construction.

RP51-02 Concerning core materials, a comprehensive analysis on the impact of fine content on watertightness is awaited in order to fix the required fine content, and adapt the processes needed to meet these specifications.

RP51-03 Moisture content of borrow area 17 is to be assessed in order to define the conditioning processes to be implemented and to adjust cost estimate.

RP51-04 international standards for testing and specifications are strongly recommended for understanding and facilitation of international tendering.

RP51-05 Perform additional campaign of testing (in both laboratory and in situ) based on international standards on all types of materials to confirm and assess previous results. Global requirements, as detailed below, should be respected:

- In situ sampling campaigns on borrow area and quarries should be undertaken following a sufficiently tight mesh all over the area, ensuring that the possible heterogeneous zones of materials are located.
- Sampling should be done at regular intervals in elevation, down to the deepest layers of the borrow areas and quarries. This requirement is to be considered especially for borrow area 17 where heterogeneous areas were reported.
- Specific remarks and detailed recommendations have been done (see report for details) for the specification and testing of each one of the materials in the dam

zoning (core material, filters and transitions, shoulder material, rip-rap, etc.) as well as for the aggregates for concrete.

### **Phase II Vol. 3 Chap. 3 Appendix 2 – RP42 – Dam Stability**

- RP42-01 Recommended investigations on material properties:
- Elasto-plastic behavior characteristics of construction materials are to be investigated according to recommendations stated in RP51, to be used in the 3D:elasto-plastic model of the dam.
- RP42-02 Recommended development of a 3D/Elasto-plastic/dynamic numerical model of the dam:
- A 3D numerical model of the dam taking into account the S-shaped, narrow gorged topography of the dam site together with the elasto-plastic is strongly recommended to test the dam performance under severe earthquakes (MCE, etc.)

### **Phase II Vol. 3 Chap. 3 Appendix 3 – RP41 – Flood management during construction**

- RP41-01 Recommended investigations in hydraulic models of evacuation tunnels:
- See notes of RP47 (Hydraulics of the project components) for the recommended investigations on the discharge organs.
- RP41-02 Recommended flood forecast system:
- A flood forecasting system is to be implemented (see also RP07 on Hydrology).
- RP41-03 Recommended Emergency Preparedness Plan:
- To be implemented prior to the river diversion.

### **Phase II Vol. 3 Chap. 3 Appendix 4 – RP47 – Hydraulics of the project components**

- RP47-01 Physical models shall be used to investigate the following five components:
- Pressure tunnels and free flow headrace tunnels
  - Vortex Spillways
  - Surface Spillway and cascade system of chutes and stilling basins
  - HLTS with cascade system of chutes and stilling basins
  - Plunge pools along the river
- RP47-02 Further investigations are required for analyzing the nature of the sediments and their potential to damage the equipment and concrete surfaces through erosion. The results of these analyzes will allow to decide whether to pass the turbidity flows through the turbines.
- RP47-03 Mathematical and physical model shall be developed to further analyze the capability of the multi-level intakes to pass turbidity flows.

### **Phase II Vol. 3 Chap. 3 Appendix5 – RP55 – PMF Management**

- RP55-01 Recommended investigations in hydraulic models of evacuation tunnels:
- See notes of RP47 (Hydraulics of the project components) for the recommended investigations on the hydraulic performance of the surface spillway.
- RP55-02 Recommended geological and geotechnical investigations in the area of the surface spillway:
- See notes of RP-45 (Geotechnics) for the recommended investigations on the geological and geotechnical characteristics of the area of the surface spillway.
- RP55-03 Recommended sedimentological investigations for the design of the surface spillway:
- See notes of RP43 (Sedimentation) for the recommended investigations on the sediments in order to add these topics in the safe design of the surface spillway.
- RP55-04 Recommended survey of current effective discharge capacity of the flood evacuation organs in the Nurek HPP and the D/S Cascade:
- A complete survey of the evacuation organs of the Nurek HPP is to be performed in order to assess its discharge capacity in order to fine tune the operations rules of the Rogun HPP for protection of the whole Vakhsh Cascade.
- RP55-05 Recommended flood forecast system:
- A flood forecasting system is to be implemented (see also RP07 on hydrology).
- RP55-06 Recommended Emergency Preparedness Plan:
- to be implemented in conjunction with the EPP for the construction phase.

### **Phase II Vol. 3 Chap. 5 – RP40 – Reservoir Operation Studies**

- RP40-01 Recommended extension (2009-2014) of length of record for simulations:
- Use the longest available river flow records for reservoir simulation studies.
- RP40-02 Recommended update of effects of sedimentation on reservoir storage capacity:
- See notes of RP-43 (Sedimentation) and update the timely evolution of the reservoir storage capacity.
- RP40-03 Recommended global optimization of the reservoir operation rules:
- The TEAS Consultant recommends a global, multipurpose optimization of the reservoir operation rules that will yield significant improvements in electricity, irrigation and environmental purposes for the whole Amu Darya Basin.

## Phase II Vol. 3 Chap. 6 – RP37 – Transmission system

- RP37-01 For the detailed transmission system analyses to be carried out before the project implementation, additional data is required regarding the following aspects:
- Monthly sharing of the demand along the year, for which a forecast along a period of about 20 years at least is required.
  - Forecast data for what attains the sharing among the various load substations. A detailed analysis would require knowing the true territorial redistribution of the loads.
  - Updated information about the load growth rate.